



Kubota



ISEKI



WWW.KOMPAKTTRAKTOR.COM

FÖRSÄLJNING AV KOMPAKTTRAKTORER OCH TILLBEHÖR



+46 73 04 333 99

KUBOTA L1-18-20-22-24-26-28-33-38-43-45 *Operation Manual*

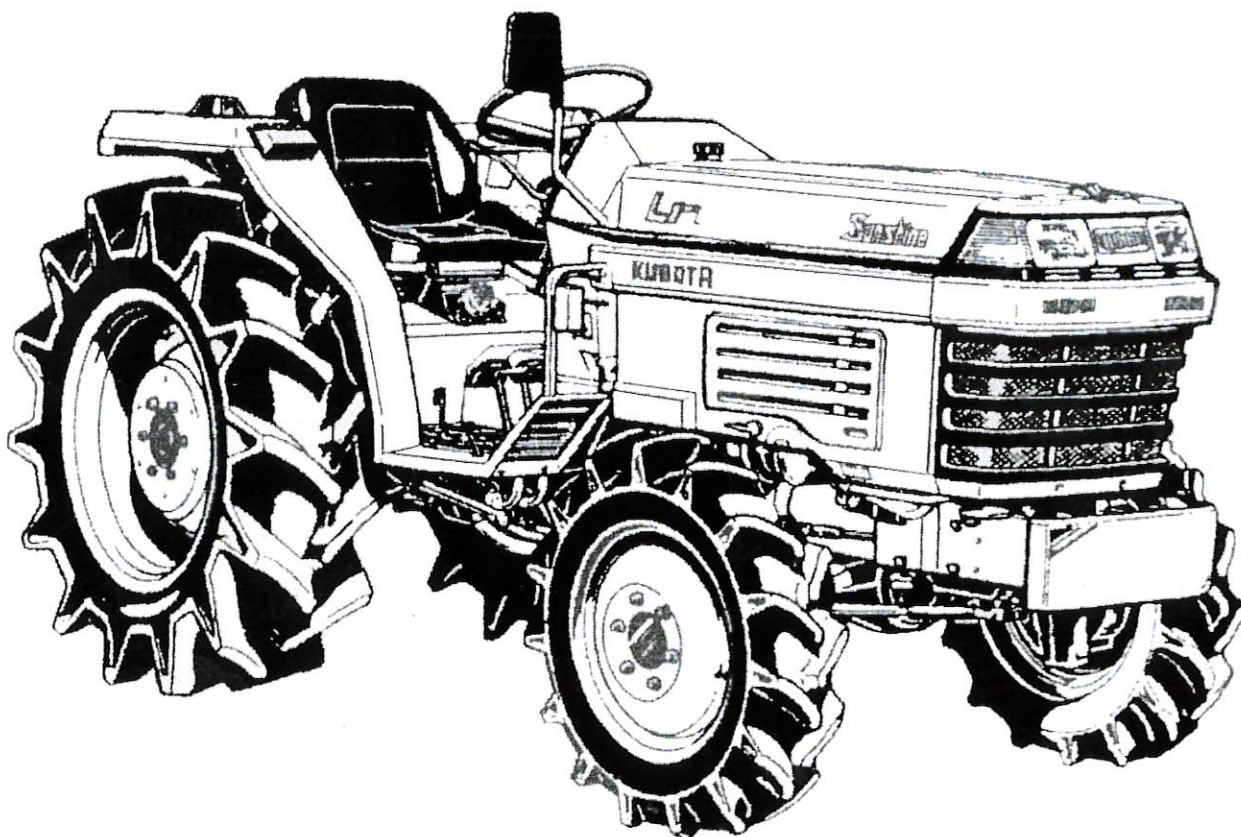

WWW.KOMPAKTTRAKTOR.COM

Norrboda, Brittusgatan 2
+46 (0)73 04 333 99

79070 Furudal
info@bushcrafttrading.com

We ask you to follow the following pages about an
“ European style “ kubota tractor.

May we remind you that your tractor was built for
Japan only.

Your tractor was imported in Europa as used machine
by non official importers.

That is why there is no literature in any European
language.

We added some translation from the Japanese
original book.

We hope that this book will help you use your tractor.

We wish you good luck with your tractor, and drive
carefully.

Kompakttraktor.com

ABBREVIATION LIST

Abbreviations	Definitions
2WD	Two Wheel Drive
4WD	Four Wheel Drive
API	American Petroleum Institute
ASAE	American Society of Agricultural Engineers, USA
ASTM	American Society for Testing and Materials, USA
DIN	Deutsches Institut für Normung, GERMANY
DT	Dual Traction [4WD]
GST	Glide Shift Transmission
HST	Hydrostatic Transmission
m/s	Meters Per Second
PT	Permanent Type (= Ethylene glycol anti-freeze)
PTO	Power Take Off
ROPS	Roll-Over Protective Structure
rpm	Revolutions Per Minute
r/s	Revolutions Per Second
SAE	Society of Automotive Engineers
SMV	Slow Moving Vehicle
SPT	Semi-Permanent Type
UDT	KUBOTA UDT fluid (Transmission-hydraulic fluid)

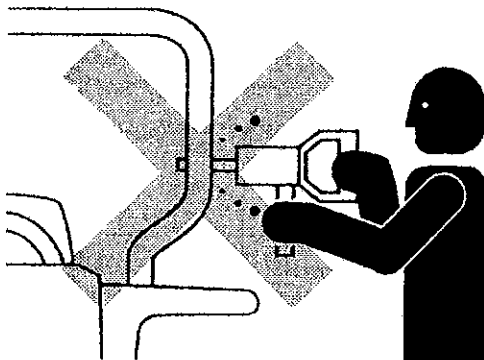
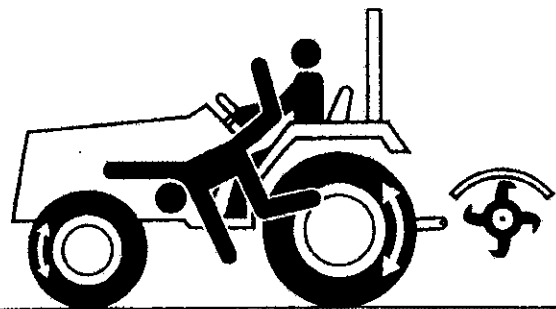
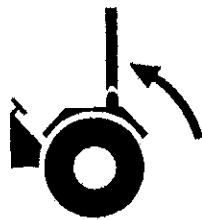
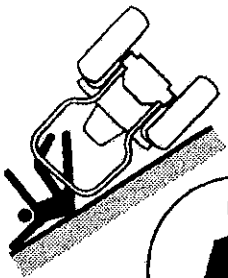
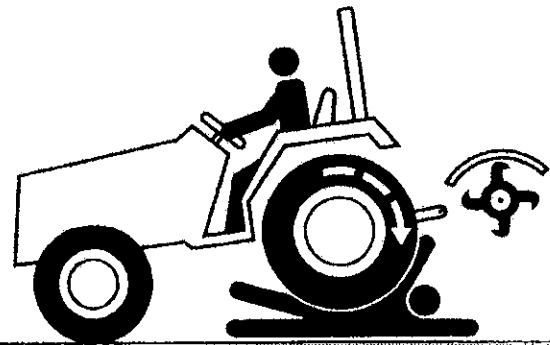
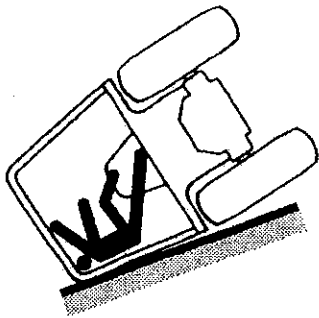
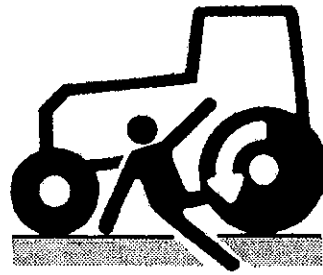
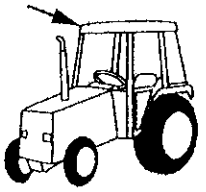
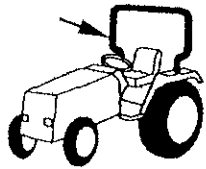

WWW.KOMPAKTTRAKTOR.COM

FÖRSÄLJNING AV KOMPAKTTRAKTORER OCH TILLBEHÖR

073 04 333 99

Bart Postema
Norrboda, Brittusgatan 2
79070 Furudal

www.bushcrafttrading.com
info@bushcrafttrading.com
+46 73 04 333 99

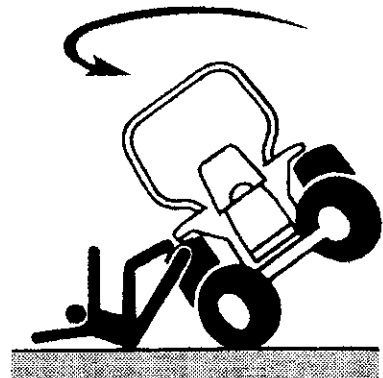
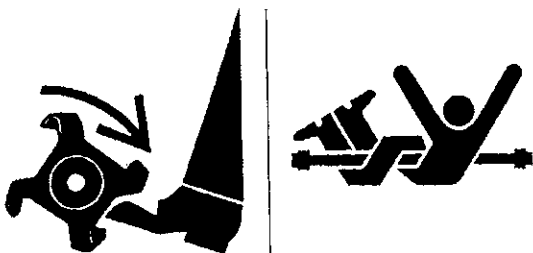
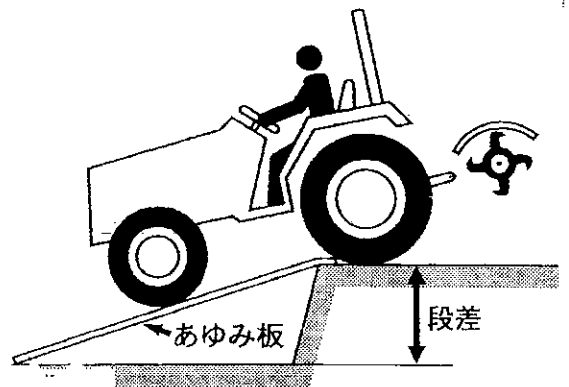
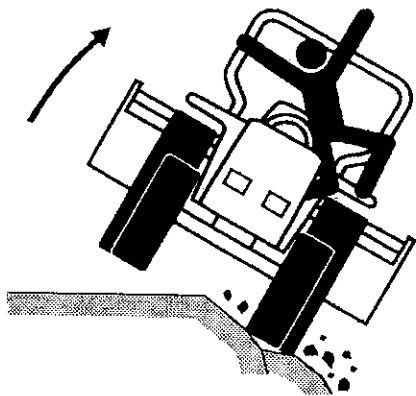
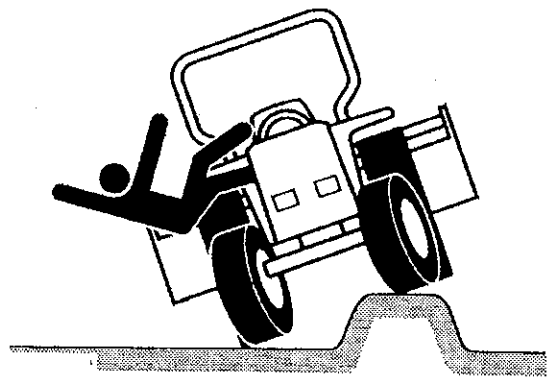
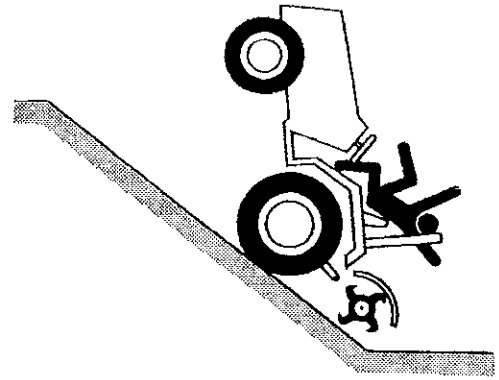
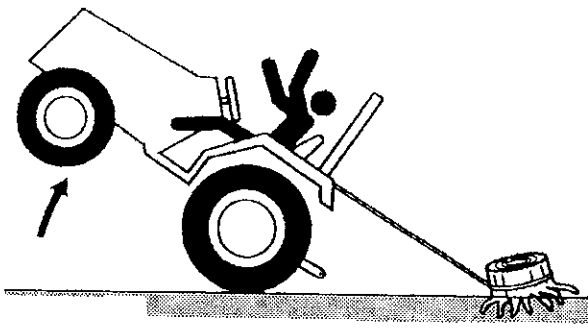

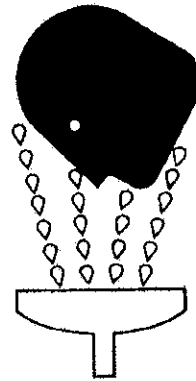
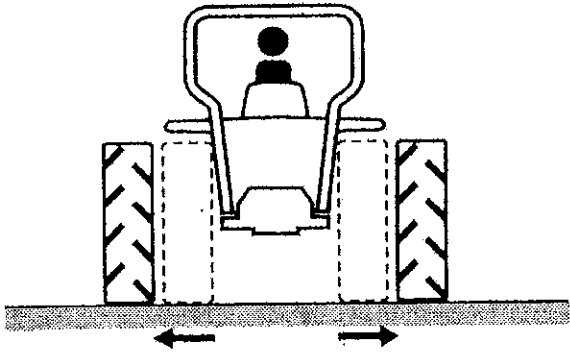
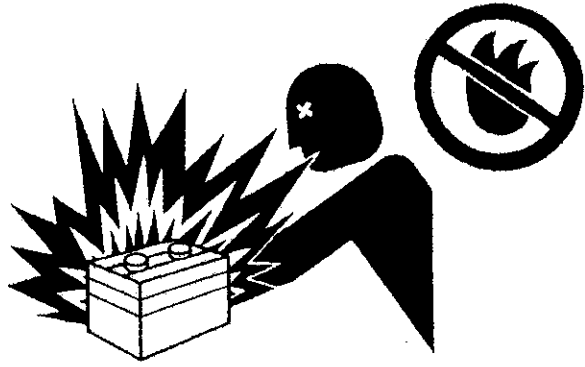
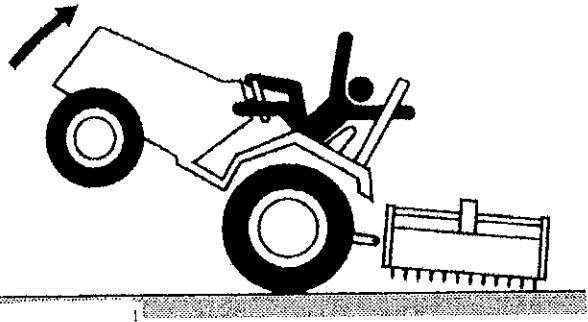

Kubota
YANMAR



WWW.KOMPAKTTRAKTOR.COM
FÖRHÄLJNING AV KOMPAKTTRAKTORER OCH TILLBEHÖR

073 04 333 99

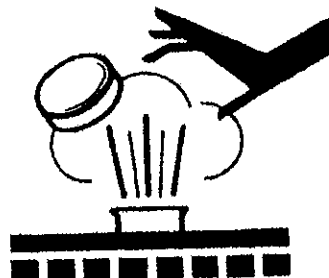
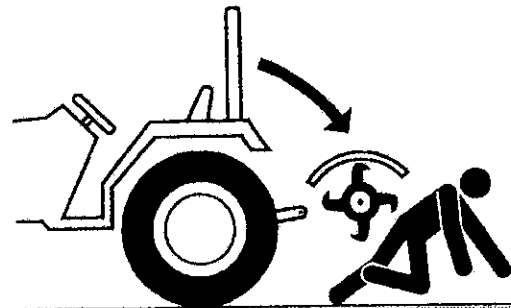
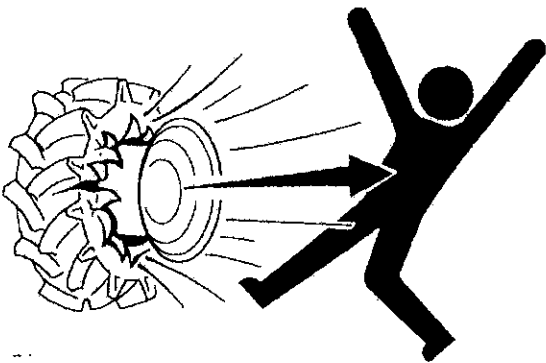

CONTENTS

▲ Safe Operation	1	11. Check and Maintenance	40
1. Servicing of Tractor	7	11.1 Fuel	40
2. Specifications	8	11.2 Engine Oil	42
2.1 Specification Table	8	11.3 Transmission Fluid	43
2.2 Traveling Speeds	10	11.4 Front Axle Case Oil [4WD]	45
3. Specifications of Implement Limitations	11	11.5 Steering Gear Box Oil	45
4. Operating New Tractor	13	11.6 Steering Gear Case Oil	46
4.1 Loading and Unloading	13	11.7 Radiator	46
5. Instrument Panel and Controls	14	11.8 Air Cleaner	48
5.1 Switches	14	11.9 Battery	49
5.2 Controls	16	11.10 Fuse and Light	50
5.3 PTO Operation	22	11.11 Rubber Lines and Hoses	51
6. Three-point Hitch & Drawbar	24	11.12 Greasing Points	52
7. Hydraulic Unit	25	12. Adjustments	53
8. Wheels, Tires and Ballast	28	12.1 Clutch Pedal Check and Adjustment	53
8.1 Wheel Adjustment	29	12.2 Brake Pedal Check and Adjustment	53
8.2 Wheel Hub	31	12.3 Toe-in Check and Adjustment	54
8.3 Tires	31	12.4 Fan Belt Adjustment	54
8.4 Ballast	32	12.5 Front Axle Back-and-Forth Play Adjustment	54
9. Operating Instructions	33	13. Storage	55
9.1 Operating the Engine	33	13.1 Tractor Storage	55
9.2 Operating the Tractor	34	13.2 Removing the Tractor from Storage	55
9.3 Pulling	36	14. Engine Troubleshooting	56
9.4 Check During Driving	36	15. Lubricant Specifications	57
10. Maintenance	37	16. Options	58
10.1 Daily Check	37	17. Wiring Diagram	59
10.2 Lubricants	38	Index	
10.3 Maintenance Check List	39		



SAFE OPERATION

Careful operation is your best insurance against an accident. Read this section carefully before operating the tractor. All operators, no matter how much experience they may have had, should read this and other related manuals before operating tractor or any implement attached to it. It is the owner's legal obligation to instruct all operators in safe operation.

1. BEFORE OPERATING THE TRACTOR

- (1) Know your equipment and its limitations. Read this entire manual before attempting to start and operate the tractor.
- (2) Pay special attention to the warning and caution labels on the tractor itself.
- (3) Kubota recommends the use of a Roll Over Protective Structures (ROPS) and seat belt in almost all applications. This combination will reduce the risk of serious injury or death should the tractor be upset. If the ROPS is loosened or removed for any reason, make sure that all parts are reinstalled correctly before operating the tractor. Never modify or repair a ROPS because welding, bending, drilling, grinding, or cutting any portion may weaken the structure. A damaged ROPS structure must be replaced, not repaired or revised. If any structural member of the ROPS is damaged, replace the entire structure at your local Kubota dealer.

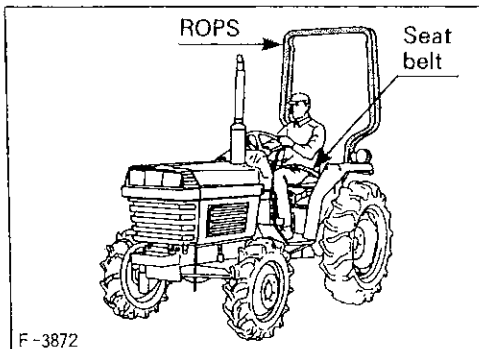

- (4) Always use the seat belt if the tractor has a ROPS. Do not use it if there is no ROPS. Check the seat belt daily and replace if frayed or damaged.
- (5) Do not operate tractor or any implement attached to it while under the influence of alcohol, medication, or other substances or while fatigued.
- (6) Carefully check the vicinity before operating tractor or any implement attached to it. Check for overhead clearance which may interfere with a ROPS. Do not allow any bystanders around or near tractor during operation.
- (7) Before allowing other people to use your tractor, explain how to operate and have them read this manual before operation.

- (8) Never wear loose, torn, or bulky clothing around tractor. It may catch on moving parts or controls, leading to the risk of accident. Use additional safety items...hard hat, safety boots or shoes, eye and hearing protection, gloves, etc. ...as appropriate or required.
- (9) Do not allow passengers or non-qualified operators on the tractor at any time. The operator must remain in the tractor seat throughout operation.
- (10) Check brakes, clutch, and other mechanical parts for faulty adjustment and wear. Replace worn or damaged parts promptly. Check the tightness of all nuts and bolts regularly. (For further details, see MAINTENANCE AND ADJUSTMENTS.)
- (11) Keep your tractor clean. Dirt, grease, and trash accumulations contribute to fires and lead to personal injury.
- (12) Use only implements meeting the specifications listed under IMPLEMENT LIMITATIONS in this manual. Use proper weights to front or rear of tractor to reduce the risk of upsets. Follow the safe operating procedures specified in the manuals included with the equipment.
- (13) The narrower the tread, the greater, the risk of a tractor upset. For maximum stability, adjust the wheels to the largest practical tread width. (See page 29, 30).

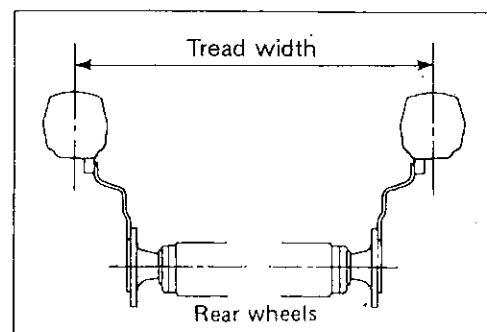

2. OPERATING THE TRACTOR

- (1) Never start engine or operate levers from anywhere other than the seat.
- (2) Before, starting the engine, make sure that all levers (including auxiliary control levers) are in their neutral positions, that the parking brake is engaged, and that both the clutch and the Power Take-Off (PTO) are disengaged.
Fasten the seat belt if the tractor has a ROPS.

- (3) Do not start engine by shorting across starter terminals or bypassing the safety start switch. Machine may start in gear and move if normal starting circuitry is bypassed.
- (4) Pull only from the drawbar. Never hitch to axle housing or any other point except drawbar; such arrangements only increase the risk of serious personal injury or death due to a tractor upset.

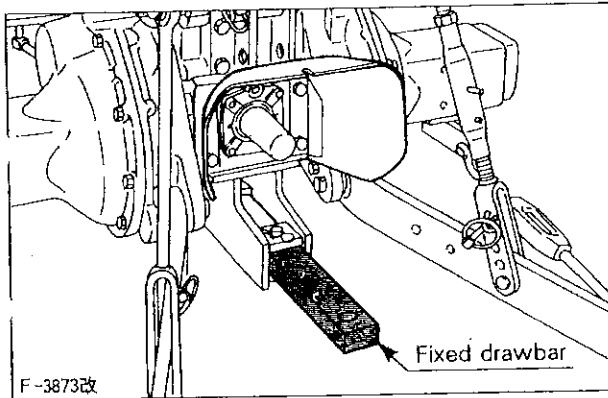

- (5) Do not operate or idle engine in a non-ventilated area. Carbon monoxide gas is colorless, odorless, and deadly.
- (6) Keep all shields and guards in place. Replace any that are missing or damaged.
- (7) Avoid sudden starts. To avoid upsets, slow down when turning, on uneven terrain, and before stopping.
- (8) The tractor cannot turn with the differential locked and attempting to do so could be dangerous.
- (9) Do not operate near ditches, holes, embankments, or other terrain features which may collapse under the tractor's weight. The risk of tractor upset is even higher when the ground is loose or wet.
- (10) Driving forward out of a ditch or mire or up a steep slope risks a tractor upset backward. Always back out of these situations. Extra caution is required with four-wheel drive models because their higher traction can give the operator false confidence in the tractor's ability to climb slopes.
- (11) To avoid upsets, always back up steep slopes. Stay off hills and slopes too steep for safe operation.
- (12) Watch where you are going at all times. Watch for and avoid obstacles. Be alert at row ends, near trees, and other obstructions.
- (13) When working in groups, always let the others know what you are going to do before you do it.
- (14) Never "freewheel". Disengaging the clutch or shifting into neutral while descending a slope could lead to a loss of control.
- (15) Never try to get on or off a moving tractor.

3. DRIVING THE TRACTOR ON THE ROAD

- (1) Lock the two brake pedals together to help assure straightline stops. Uneven braking at road speeds could cause the tractor to roll over.

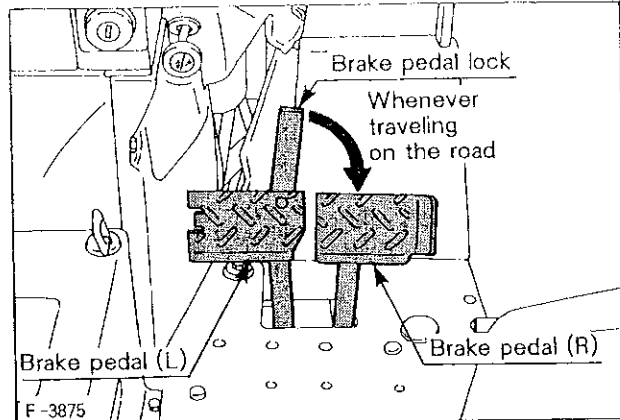

- (2) Always slow the tractor down before turning. Turning at high speed may tip the tractor over.
- (3) Make sure that the Slow-Moving Vehicle (SMV) emblem is clean and visible. Use hazard lights as required.

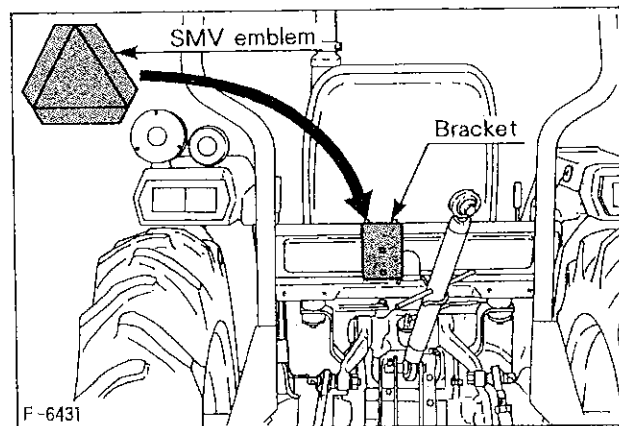

- (4) Observe all local traffic and safety regulations.
- (5) Turn the headlights on. Dim them when meeting another vehicle.
- (6) Drive at speeds that allow you to maintain control at all times.
- (7) Do not apply the differential lock while traveling at road speeds. The tractor may run out of control.
- (8) Avoid sudden motions of the steering wheel as they can lead to a dangerous loss of stability. The risk is especially great when the tractor is traveling at road speeds.
- (9) Do not operate an implement while the tractor is on the road. Lock it in the raised position.
- (10) When towing other equipment, use a safety chain and place an SMV emblem on it as well.

4. STOPPING THE TRACTOR

- (1) Disengage the PTO, lower all implements, place all control levers in their neutral positions, apply parking brake, turn off the engine, and remove the key.
- (2) Make sure that the tractor has come to a complete stop before dismounting.

5. OPERATING THE PTO

- (1) Wait until all moving components have completely stopped before getting off the tractor, connecting, disconnecting, adjusting, cleaning, or servicing any PTO-driven equipment.
- (2) Keep the PTO shaft cover in place at all times. Replace the PTO shaft cap when the shaft is not in use.

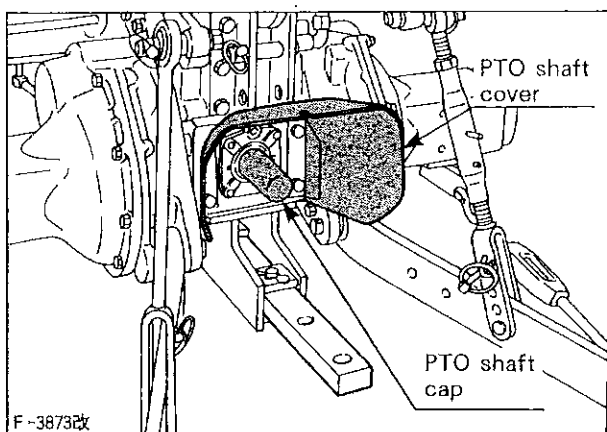

- (3) Before installing or using PTO-driven equipment, read the manufacturer's manual and review the safety labels attached to the equipment.
- (4) To prevent PTO-driven equipment from racing out of control, stick to the lower (540 rpm) speed unless the higher (1000 rpm) one is specifically recommended as safe by the equipment manufacturer.

[Except L3250]

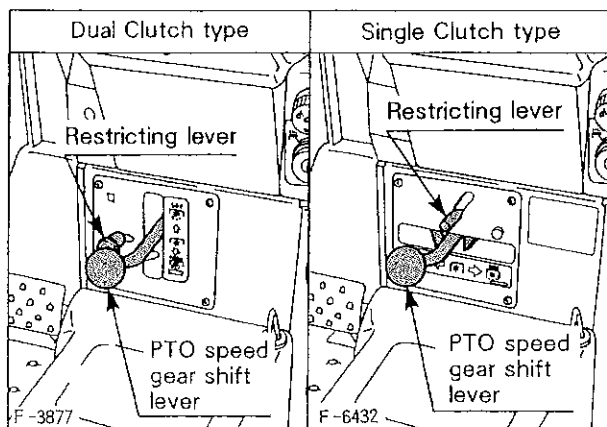

- (5) When operating stationary PTO driven equipment, always apply the tractor parking brake and place chocks behind and in front of the rear wheels. Stay clear of all rotating parts.

6. USING 3-POINT HITCH

- (1) Use the 3-point hitch only with equipment designed for 3-point hitch usage.

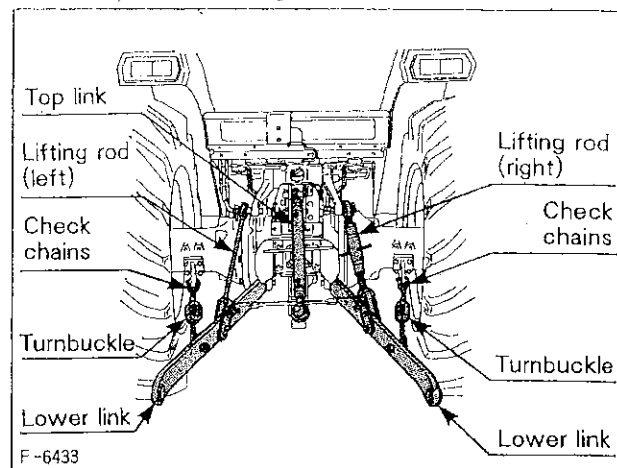

- (2) When using a 3-point hitch mounted implement, be sure to install the proper counterballast weight on the front of the tractor.
- (3) When transporting on the road, set the implement lowering control in the "lock" position to hold the implement in the raised position.

7. SERVICING THE TRACTOR

Before servicing the tractor, park it on a firm level surface, set the parking brake, place the gear shift lever in neutral and stop the engine.

- (1) Allow the tractor time to cool off before working on or near the engine, muffler, radiator, etc.
- (2) Always stop the engine before refueling. Avoid spills and overfilling.

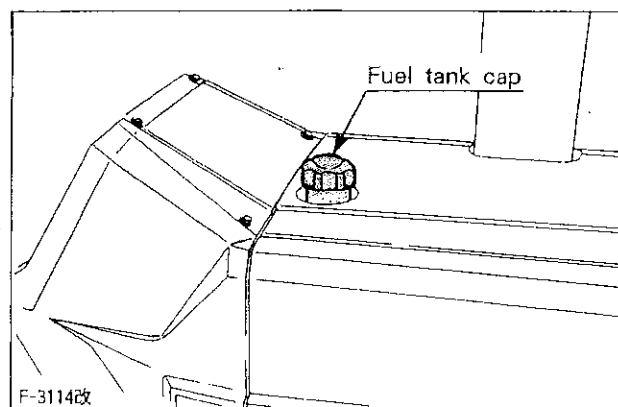

- (3) Do not smoke when working around battery or when refueling. Keep all sparks and flames away from battery and fuel tank. The battery presents an explosion hazard because it gives off hydrogen and oxygen.....especially when recharging.
- (4) Before "jumping" a dead battery, read and follow all of the instructions. (See page 4)
- (5) Keep first aid kit and fire extinguisher handy at all times.

- (6) Do not remove radiator cap while coolant is hot. When cool, slowly rotate cap to the first stop and allow sufficient time for excess pressure to escape before removing the cap completely. If the tractor has a coolant recovery tank, add coolant there instead of to the radiator.
- (7) Disconnect the battery's ground cable before working on or near electric components.
- (8) To avoid sparks from an accidental short circuit, always disconnect the battery's ground cable \ominus first and connect it last.

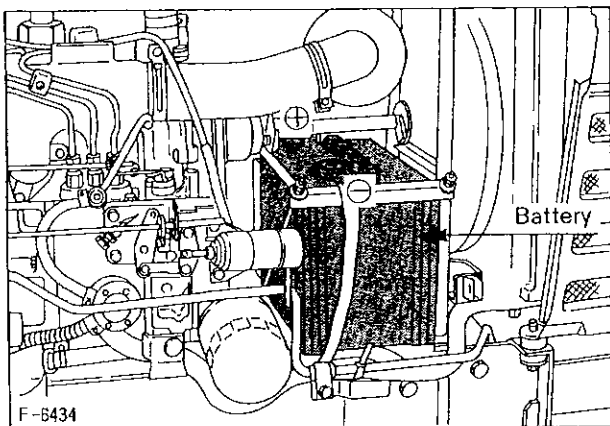

- (9) Do not attempt to mount a tire on a rim unless qualified to do so and all proper safety precautions are followed.
- (10) Provide adequate support when changing wheels or the wheel tread width.
- (11) Make sure that wheel bolts have been tightened to the specified torque.
- (12) Escaping hydraulic fluid under pressure has sufficient force to penetrate skin, causing serious personal injury. Before disconnecting hydraulic lines, be sure to release all residual pressure. Before applying pressure to the hydraulic system, make sure that all connections are tight and that all lines, pipes, and hoses are free of damage.

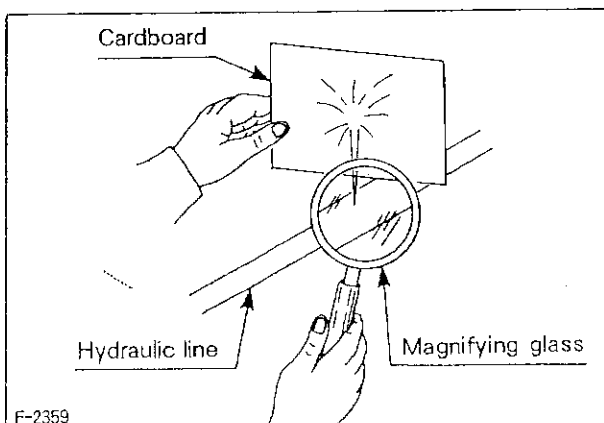

Fluid escaping from pinholes may be invisible. Do not use hands to search for suspected leaks; Use a piece of cardboard or wood, instead. Use of safety goggles or other eye protection is also highly recommended.

If injured by escaping fluid, see a medical doctor at once. This fluid can produce gangrene or severe allergic reaction.

8. JUMP STARTING INSTRUCTIONS AND PRECAUTIONS

If ice is present or the battery is cracked, DO NOT ATTEMPT TO "JUMP START" vehicle.

- (1) Bring helper vehicle with a battery of the same voltage as disabled tractor within easy cable reach. "THE VEHICLES MUST NOT TOUCH."
- (2) Engage the parking brakes of both vehicles and put all shift levers in neutral. Turn both key switches off.
- (3) Put on safety goggles and rubber gloves.
- (4) Remove the vent caps from both batteries.
- (5) Cover vent holes with damp rags. Do not allow the rags to touch the battery terminals.
- (6) Attach the red clamp to the positive (red, \oplus or pos.) terminal of the dead battery and clamp the other end of the same cable to the positive (red, \oplus or pos.) terminal of the helper battery.
- (7) Clamp the other cable to the negative (black, \ominus or neg.) terminal of the helper battery.
- (8) Clamp the other end to the engine block or frame of the disabled tractor as far from the dead battery as possible.
- (9) Start the helper vehicle and let its engine run for a few moments. Start the disabled tractor.
- (10) Disconnect the jumper cables in the exact reverse order of attachment. (Steps 8, 7 and 6).
- (11) Remove and discard the damp rags. Reinstall the vent caps.

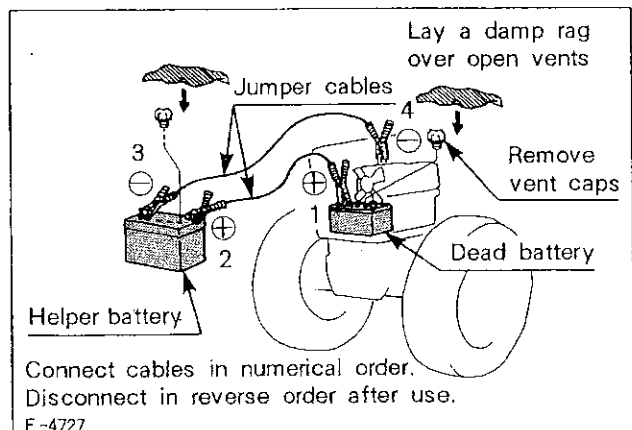

9. WARNING AND CAUTION LABELS

❶ Part No. 35260-3491-3

⚠ CAUTION

TO AVOID PERSONAL INJURY:

1. Read and understand the operator's manual before operation.
2. Before starting the engine, make sure that everyone is at a safe distance from the tractor and that the PTO is OFF.
3. Do not allow passengers on the tractor at any time.
4. Before allowing other people to use the tractor, have them read the operator's manual.
5. Check the tightness of all nuts and bolts regularly.
6. Keep all shields in place and stay away from all moving parts.
7. Lock the two brake pedals together before driving on the road.
8. Slow down for turns, or rough roads, or when applying individual brakes.
9. On public roads use SMV emblem and hazard lights, if required by local traffic and safety regulations.
10. Pull only from the drawbar.
11. Before dismounting, lower the implement, set the parking brake, stop the engine and remove the key.

❷ Part No. 35260-2979-1

⚠ WARNING

TO AVOID PERSONAL INJURY:

1. Attach pulled or towed loads to the drawbar only.
2. Use the 3-point hitch only with equipment designed for 3-point hitch usage.

❸ Part No. 35820-9863-3

⚠ WARNING

TO AVOID POSSIBLE INJURY OR DEATH FROM A MACHINE RUNAWAY:

1. Do not start engine by shorting across starter terminals or bypassing the safety start switch. Machine may start in gear and move if normal starting circuitry is bypassed.
2. Start engine only from operator's seat with transmission and PTO OFF.
Never start engine while standing on the ground.

❹ Part No. 35260-2978-2

⚠ WARNING

TO AVOID PERSONAL INJURY OR DEATH FROM ROLL-OVER:

1. Kubota recommends the use of a Roll-Over Protective Structures (ROPS) and seat belt in almost all applications.
2. Remove the ROPS only when it substantially interferes with operation or itself presents a safety risk. (Examples include work in orchards and vineyards.)
ALWAYS REINSTALL IT BEFORE USING THE TRACTOR IN OTHER APPLICATIONS.
3. Never use just the seat belt or just the ROPS. They must be used together. For further details, consult your Operator's Manual or your local dealer.

❺ Part No. 35200-2534-1

⚠ WARNING

TO AVOID PERSONAL INJURY:

1. Keep PTO shield in place at all times.
2. Do not operate the PTO at speeds faster than the speed recommended by the implement manufacturer.

- ⑥ [With mid-PTO]
Part No. 32430-6575-1

⚠ WARNING

TO AVOID PERSONAL INJURY:

Do not operate rear-PTO driven implements and mid-PTO driven implements at the same time.

- ⑦ [With Glide Shift Transmission]
Part No. 35370-3136-3

⚠ WARNING

BEFORE DISMOUNTING TRACTOR:

1. ALWAYS SET PARKING BRAKE
Leaving transmission in gear with the engine stopped will not prevent tractor with shuttle transmission from rolling.
2. LOCK SHUTTLE SHIFT LEVER IN NEUTRAL POSITION
This prevents movement of shuttle shift lever out of neutral position.
3. STOP THE ENGINE

- ⑧ Part No. 35080-6528-2

⚠ CAUTION

Pull the engine stop knob back and hold it until the engine stops in case of emergency.

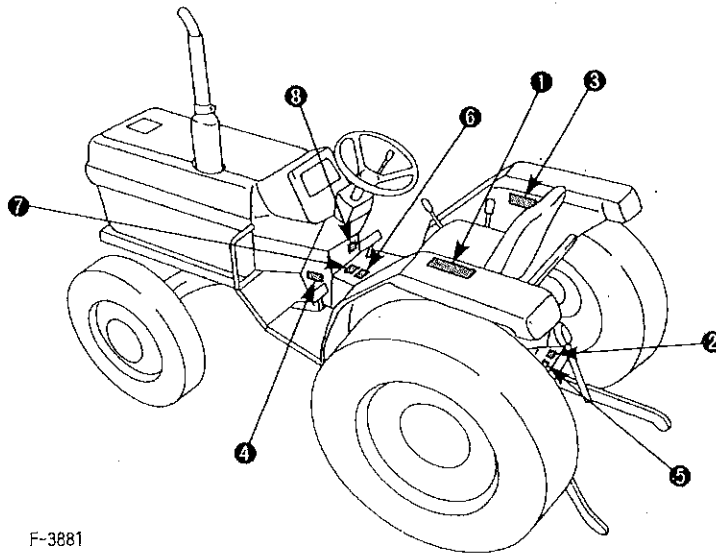

F-3881

CARE OF WARNING AND CAUTION LABELS

- (1) Keep warning and caution labels clean and free from obstructing material.
- (2) Clean warning and caution labels with soap and water, dry with a soft cloth.
- (3) Replace damaged or missing warning and caution labels with new labels from your Kubota dealer.
- (4) If a component with warning and caution label(s) affixed is replaced with new part, make sure new label(s) is (are) attached in the same location(s) as the replaced component.
- (5) Mount new warning and caution labels by applying on a clean dry surface and pressing any bubbles to outside edge.

1. SERVICING OF TRACTOR

Your dealer is interested in your new tractor and has the desire to help you get the most value from it. After reading this manual thoroughly, you will find that you can do some of the regular maintenance yourself.

However, when in need of parts or major service, be sure to see your KUBOTA dealer.

For service, contact the KUBOTA Dealership from which you purchased your tractor or your local authorized KUBOTA dealer.

When in need of parts, be prepared to give your dealer both the tractor and engine serial numbers.

The tractor serial number is located on the transmission housing on the right-hand side of the tractor. The engine serial number is located on the engine crankcase, right side.

Locate the serial numbers now and record them in the space provided.

	Type	Serial No.
Tractor	_____	_____
Engine	_____	_____
Date of Purchase	_____	_____
(To be filled in by purchaser)		

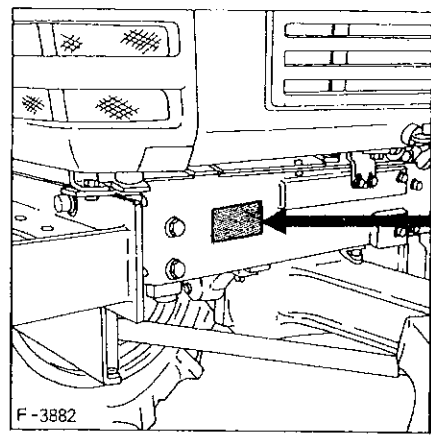

Identification plate

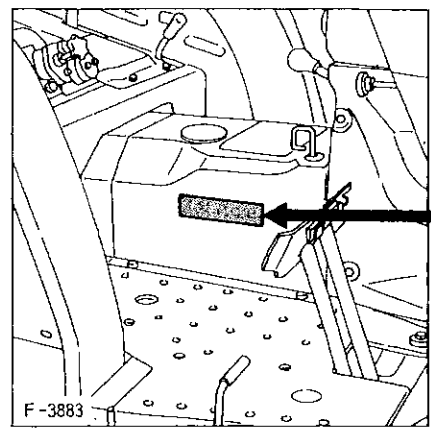

Tractor serial number

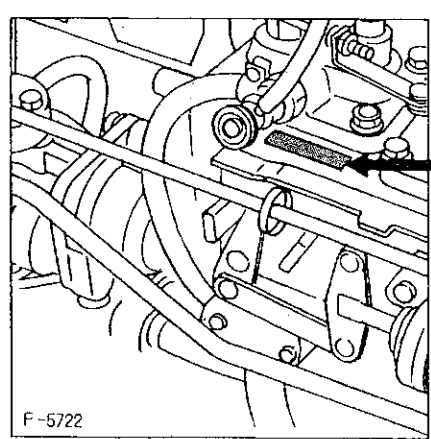

Engine serial number

2. SPECIFICATIONS

2.1 SPECIFICATION TABLE

Model	L2250 (2WD)	L2250 (4WD)	L2550 (2WD)	L2550 (4WD)	L2850 (2WD)	L2850 (4WD)	L3250 (2WD)	L3250 (4WD)		
Engine gross power	19.8kW (26.5HP)*		22.0kW (29.5HP)*		25.4kW (34HP)*		29.8kW (40HP)*			
PTO power	15.7kW (21HP)*		17.5kW (23.5HP)*		20.1kW (27HP)*		23.9kW (32HP)*			
Model	KUBOTA D 1302-DI-A		KUBOTA D 1402-DI-A		KUBOTA V 1702-DI-A		KUBOTA V 1902-DI-A			
Type	Direct Injection, Vertical, Water-Cooled 4 cycle diesel									
No. of cylinders	3				4					
Bore and stroke	82 X 82 mm (3.2 X 3.2 in.)		85 X 82 mm (3.3 X 3.2 in.)		82 X 82 mm (3.2 X 3.2 in.)		85 X 82 mm (3.3 X 3.2 in.)			
Total displacement	1299 cm ³ (79.3 cu. in.)		1395 cm ³ (85.1 cu. in.)		1732 cm ³ (105.7 cu. in.)		1861 cm ³ (113.6 cu. in.)			
Rated revolution	43.3 r/s (2600 rpm)									
Fuel	Diesel fuel No.1 [below -10°C (14°F)] Diesel fuel No.2 [above -10°C (14°F)]									
Starter	Electric starter 12V, 1.2kW (1.6HP)				Electric starter 12V, 1.4kW (1.9HP)					
Lubrication	Forced lubrication by trochoidal pump									
Cooling	Water with pressurized radiator									
Battery	12V 65 Ah eq.				12V 70 Ah eq.					
Fuel tank	29 ℓ (7.7 U.S. gals.)									
Engine crankcase	5.7 ℓ (6.0 U.S. qts.)				8.5 ℓ (8.9 U.S. qts.)					
Engine coolant	4.6 ℓ (4.9 U.S. qts.)				5.6 ℓ (5.9 U.S. qts.)					
Transmission case	28.5 ℓ (7.5 U.S. gals.)									
Steering gear case	0.1 ℓ (0.11 U.S. qt.)									
Steering gear box	0.2 ℓ (0.21 U.S. qt.)									
Front axle case	-	6 ℓ (6.3 U.S. qts.)	-	6.5 ℓ (6.8 U.S. qts.)	-	6.5 ℓ (6.8 U.S. qts.)	-	6.5 ℓ (6.8 U.S. qts.)		
Tires	Front	4.00-15	6-14	5.00-15	7-16	5.00-15	7-16	6.00-16	8-16	
	Rear	9.5-24	9.5-24	11.2-24	11.2-24	12.4-24	12.4-24	13.6-26	13.6-26	
Dimensions	Overall length ^(without sp) mm (in.)	2750 (108.3)		2770 (109.1)		2900 (114.2)		2950 (116.1)		
	Overall width mm (in.)	1255 (49.4)		1305 (51.4)		1370 (53.9)		1480 (58.3)		
	Overall height mm (in.)	2030 (79.9)		2030 (79.9)		2030 (79.9)		2050 (80.7)		
	Wheel base mm (in.)	1640 (64.6)				1735 (68.3)				
	Min. ground clearance mm (in.)	345 (13.6)	305 (12.0)	370 (14.6)	345 (13.6)	355 (14.0)	345 (13.6)	365 (14.4)	360 (14.2)	
	Treads	Front mm (in.)	1010 (39.8)	1010 (39.8)	960 (37.8) 1060 (41.7) 1160 (45.7) 1260 (49.6)	1120 (44.1)	1150 (45.3) 1250 (49.2) 1350 (53.1) 1450 (57.1)	1120 (44.1)	1150 (45.3) 1250 (49.2) 1350 (53.1) 1450 (57.1)	1170 (46.1)
Rear mm (in.)		1015 (40.0) 1135 (44.7)		1030 (40.6), 1125 (44.3), 1220 (48.0), 1305 (51.4), 1400 (55.1)		1050 (41.3), 1150 (45.3), 1240 (48.8), 1335 (52.6), 1420 (55.9), 1515 (59.6)		1155 (45.5), 1225 (48.2), 1325 (52.2), 1350 (53.1), 1450 (57.1)		
Weight	kg (lbs.)		985 (2170)	1080 (2380)	1020 (2250)	1120 (2470)	1125 (2480)	1230 (2710)	1150 (2530)	1245 (2740)
Rear PTO	SAE 1-3/8 6-splines (with overrunning clutch on single clutch tractor)									
Revolution	with single clutch	2 speeds 9r/s (540rpm)/engine 40.5r/s (2430rpm), 16.7r/s (1000rpm)/engine 40.6r/s (2438rpm)						-		
	with dual clutch	2 speeds 9r/s (540rpm)/engine 38.3r/s (2298rpm), 16.7r/s (1000rpm)/engine 40.6r/s (2438rpm)						1 speed 9r/s (540rpm) engine 38.3r/s (2300rpm)		
MID-PTO (if equipped)	USA No.5 (KUBOTA 10 tooth) Involute spline									
Revolution	with single clutch	2 speeds 18r/s (1080rpm)/engine 40.5r/s (2430rpm), 33.3r/s (2000rpm)/engine 40.6r/s (2438rpm)						-		
	with dual clutch	2 speeds 18r/s (1080rpm)/engine 38.3r/s (2298rpm), 33.3r/s (2000rpm)/engine 40.6r/s (2438rpm)						-		
Clutch	Dry single plate or two plate (live PTO: if equipped)							Dry two plate (live PTO)		
Steering	Recirculating ball type manual steering or integral type power steering (if equipped)									
Transmission	Mechanical shuttle, 8 forward and 8 reverse									
Min. turning radius	m (feet)		2.3 (7.5)	2.2 (7.2)	2.3 (7.5)	2.3 (7.5)	2.4 (7.9)	2.4 (7.9)	2.4 (7.9)	2.5 (8.2)
Brake	Wet disk type									
Differential	Bevel gear									

Note: *Manufacturer's estimate

Model		L2550GST (4WD)	L2850GST (4WD)	
Engine gross power		22.0kW (29.5HP)*	25.4kW (34HP)*	
PTO power		17.5kW (23.5HP)*	20.1kW (27HP)*	
Engine	Model	KUBOTA D 1402-DI-AE	KUBOTA V 1702-DI-AE	
	Type	Direct injection, Vertical, Water-Cooled 4 cycle diesel		
	No. of cylinders	3	4	
	Bore and stroke	85X82mm (3.3X3.2 in.)	82X82mm (3.2X3.2 in.)	
	Total displacement	1395cm ³ (85.1 cu.in.)	1732cm ³ (105.7 cu.in.)	
	Rated revolution	43.3r/s (2600 rpm)		
	Fuel	Diesel fuel No.1 [below -10°C (14°F)] Diesel fuel No.2 [above -10°C (14°F)]		
	Starter	Electric starter 12V, 1.2kW (1.6HP)	Electric starter 12V, 1.4kW (1.9HP)	
	Lubrication	Forced lubrication by trochoidal pump		
	Cooling	Water with pressurized radiator		
Battery	12V 65 Ah eq.	12V 70 Ah eq.		
Capacities	Fuel tank	29 ℓ (7.7 U.S.gals.)		
	Engine crankcase	5.7 ℓ (6.0 U.S. qts.)	8.5 ℓ (8.9 U.S. qts.)	
	Engine coolant	4.6 ℓ (4.9 U.S. qts.)	5.6 ℓ (5.9 U.S. qts.)	
	Transmission case	27 ℓ (7.1 U.S. gals.)		
	Steering gear case	0.1 ℓ (0.11 U.S. qt.)		
	Front axle case	6.5 ℓ (6.8 U.S. qts.)		
Tires	Front	7-16		
	Rear	11.2-24	12.4-24	
Dimensions	Overall length (without 3P)	mm (in.)	2770 (109.1)	2900 (114.2)
	Overall width	mm (in.)	1305 (51.4)	1370 (53.9)
	Overall height	mm (in.)	2030 (79.9)	
	Wheel base	mm (in.)	1640 (64.6)	1735 (68.3)
	Min. ground clearance	mm (in.)	345 (13.6)	
	Treads	Front	mm (in.)	1120 (44.1)
Rear		mm (in.)	1030 (40.6), 1125 (44.3), 1220 (48.0), 1305 (51.4), 1400 (55.1)	1050 (41.3), 1150 (45.3), 1240 (48.8), 1335 (52.6), 1420 (55.9), 1515 (59.6)
Weight	kg (lbs.)	1160 (2557)	1270 (2800)	
Rear PTO	SAE 1-3/8 6-splines (with overrunning clutch)			
Revolution	2 speeds 9 r/s (540 rpm) /engine 40.5 r/s (2430 rpm), 16.7 r/s (1000 rpm) /engine 40.6 r/s (2438 rpm)			
MID-PTO	USA No.5 (KUBOTA 10 tooth) Involute spline			
Revolution	2 speeds 18 r/s (1080 rpm) /engine 40.5 r/s (2430 rpm), 33.3 r/s (2000 rpm) /engine 40.6 r/s (2438 rpm)			
Clutch	Dry single plate			
Steering	Integral type power steering			
Transmission	Glide Shift Transmission, 8 forward and 8 reverse			
Min. turning radius	m (feet)	2.3 (7.5)	2.4 (7.9)	
Brake	Wet disk type			
Differential	Bevel gear			

Note: *Manufacturer's estimate

主要諸元

■トラクタの主要諸元

(3点リンク・モンロー付き)

型 式	Lr-18	Lr-18D	Lr-20	Lr-20D	Lr-22	Lr-22D	Lr-24	Lr-24D	Lr-26	Lr-26D	Lr-28	Lr-28D	
駆 動 方 式	2輪駆動	4輪駆動	2輪駆動	4輪駆動	2輪駆動	4輪駆動	2輪駆動	4輪駆動	2輪駆動	4輪駆動	2輪駆動	4輪駆動	
機 体 寸 法	全 長(mm)	2890				2940				3090		3160	
	全 幅(mm)	1190		1255		1260		1320		1380		1420	
	全 高(mm)	1980		1975								1980	1975
	軸 距(mm)	1500				1550				1685		1735	
	輪 距	前輪(mm)	880	940	960	940	960	940	980-1140 (3段)	1050	1050-1450 (5段)	1050	1050-1450 (5段)
	後輪(mm)	950, 1070		990, 1110				1020-1320 (6段)		1050-1520 (6段)		1080-1550 (6段)	
	最低地上高(mm)	320	275	340	275	345	275	370	315	355	315	365	315
重 量(kg)	890	975	930	980	955	1010	990	1070	1080	1150	1155	1190	
エ ン ジ ン	名 称	クボタ D1302-D1		クボタ D1402-D1		クボタ D1462-D1 (-L)		クボタ D1462-D1		クボタ V1512-D1 (-L)		クボタ V1512-D1	
	形 式	水冷4サイクル3気筒立形ディーゼル								水冷4サイクル 4気筒立形ディーゼル			
	総排気量(cc)	1299		1395		1462				1499			
	出力/回転速度 (PS/rpm)	18/2500		20/2500		22/2500		24/2600		26/2600		28/2700	
	使用燃料	クボタディーゼル重油又はディーゼル軽油											
	燃料タンク容量 (ℓ)	29											
始 動 方 式	セルモータ式 (グロープラグ付)												
バ ッ テ リ	N70Z				NX120-7								
タ イ ヤ	前 輪	4.00-12 4PR	6-14 4PR	4.00-15 4PR	6-14 4PR	4.00-15 4PR	6-14 4PR	5.00-15 4PR	7-16 4PR	5.00-15 4PR	7-16 4PR	5.00-15 4PR	7-16 4PR
	後 輪	8.3-24 4PR ニューバランスタイヤ		9.5-22 4PR ニューバランスタイヤ		9.5-24 4PR ニューバランスタイヤ		11.2-24 4PR ニューバランスタイヤ		12.4-24 4PR ニューバランスタイヤ		13.6-24 4PR ニューバランスタイヤ	
車 体	クラッチ方式	乾式単板 (シングル, ダブル)											
	制 動 装 置	一系統左右独立(連結装置付) 湿式ディスクブレーキ(機械式)											
	かじ取り方式	ボールスクリュース式 (インテグラルパワーステアリング)											
	差 動 方 式	2ピニオンかさ歯車式(デフロック付)						4ピニオンかさ歯車式(デフロック付)					
変 速 方 式	コンスタントメッシュ												
変 速 段 数 (段)	前進16, 後進16 (シャトル)												
走 行 速 度 (km/h)	前 進	0.23~14.50		0.23~14.57		0.24~14.26		0.23~14.89		0.24~14.55		0.24~14.68	
	後 進	0.20~11.67		0.20~11.76		0.23~12.45		0.22~13.53		0.22~12.16		0.22~12.32	
最 小 旋 回 半 径 (ブレーキ使用時)	2.1	2.0	2.1	2.0	2.2	2.0	2.2	2.1	2.3	2.2	2.4	2.3	
P T O	回転/エンジン 速度/回転速度	556, 774, 938, 1250/2500						578, 805, 975, 1300/2600		578, 805, 1000, 1300/2600		600, 836, 1038, 1350/2700	
	(rpm)	—				588, 716, 1026, 1250/2500		611, 745, 1067, 1300/2600				634, 774, 1107, 1350/2700	
軸 寸 法(mm)	JIS 35												
作 業 機 器	制 御 方 式	ポジションコントロール											
	装 着 方 式	3点リンク JIS 1形											

2.2 TRAVELING SPEEDS (At rated engine rpm)

Model			L2250		L2550		L2850		L3250	
Tire size (Rear)			9.5-24		11.2-24		12.4-24		13.6-26	
	Hi-Lo gear shift lever	Main gear shift lever	km/h	mph	km/h	mph	km/h	mph	km/h	mph
Forward	Low	1	1.4	0.9	1.5	0.9	1.3	0.8	1.4	0.9
		2	1.9	1.2	2.0	1.3	1.8	1.1	2.0	1.2
		3	3.0	1.9	3.2	2.0	2.9	1.8	3.1	1.9
		4	4.3	2.7	4.5	2.8	4.2	2.6	4.6	2.9
	High	1	6.7	4.2	7.0	4.4	6.3	3.9	6.9	4.3
		2	9.4	5.8	9.8	6.1	8.8	5.5	9.6	6.0
		3	14.7	9.1	15.4	9.5	13.8	8.6	15.1	9.4
		4	20.8	12.9	21.7	13.5	20.4	12.7	22.3	13.9
Reverse	Low	1	1.3	0.8	1.3	0.8	1.2	0.7	1.2	0.8
		2	1.7	1.1	1.8	1.1	1.6	1.0	1.8	1.1
		3	2.7	1.7	2.9	1.8	2.6	1.6	2.8	1.7
		4	3.9	2.4	4.0	2.5	3.8	2.4	4.2	2.6
	High	1	6.0	3.8	6.3	3.9	5.7	3.5	6.2	3.9
		2	8.4	5.2	8.8	5.5	7.9	4.9	8.7	5.4
		3	13.2	8.2	13.8	8.6	12.4	7.7	13.6	8.5
		4	18.7	11.6	19.6	12.2	18.4	11.4	20.1	12.5

Model		L2550GST		L2850GST	
Tire size (Rear)		11.2-24		12.4-24	
	Main gear shift lever	km/h	mph	km/h	mph
Forward	1	1.6	1.0	1.4	0.9
	2	2.2	1.4	2.0	1.2
	3	3.4	2.1	3.1	1.9
	4	4.9	3.0	4.4	2.7
	5	6.9	4.3	6.8	4.2
	6	9.6	6.0	9.4	5.9
	7	15.0	9.3	14.7	9.2
	8	21.4	13.3	21.1	13.1
Reverse	1	1.4	0.9	1.2	0.7
	2	2.0	1.2	1.6	1.0
	3	3.1	1.9	2.5	1.6
	4	4.4	2.7	3.6	2.2
	5	6.2	3.9	5.5	3.4
	6	8.6	5.3	7.7	4.8
	7	13.4	8.3	12.1	7.5
	8	19.1	11.9	17.2	10.7

The company reserves the right to change the specifications without notice.

3. SPECIFICATIONS OF IMPLEMENT LIMITATIONS

The Kubota Tractor has been thoroughly tested for proper performance with implements sold or approved by KUBOTA. Use with implements which exceed the maximum specifications listed below, or which are otherwise unfit for use with the Kubota Tractor may result in malfunctions or failures of the tractor, damage to other property and injury to the operator or others. [Any malfunctions or failures of the tractor resulting from use with improper implements are not covered by the warranty.]

	Tread (max. width) with farm tires			Lift capacity Lower link end W_0
	Front		Rear	
	2WD	4WD		
L2250	1010 mm (40 in.)	1010 mm (40 in.)	1135 mm (45 in.)	850 kg (1875 lbs.)
L2550	1260 mm (50 in.)	1120 mm (44 in.)	1400 mm (55 in.)	1100 kg (2425 lbs.)
L2850	1450 mm (57 in.)	1120 mm (44 in.)	1515 mm (60 in.)	1100 kg (2425 lbs.)
L3250	1450 mm (57 in.)	1170 mm (46 in.)	1450 mm (57 in.)	1100 kg (2425 lbs.)

	Actual figures			
	Trailer loading weight W_2 Max. capacity		Max. Drawbar Load W_3 2WD, 4WD	Lift capacity 24 inch behind lower link end W_1
	2WD	4WD		
L2250	1000 kg (2200 lbs.)	1000 kg (2200 lbs.)	330 kg (730 lbs.)	650 kg (1430 lbs.)
L2550	1500 kg (3300 lbs.)	1500 kg (3300 lbs.)	500 kg (1100 lbs.)	820 kg (1810 lbs.)
L2850	2000 kg (4400 lbs.)	2000 kg (4400 lbs.)	650 kg (1430 lbs.)	850 kg (1875 lbs.)
L3250	2500 kg (5500 lbs.)	2500 kg (5500 lbs.)	650 kg (1430 lbs.)	850 kg (1875 lbs.)

Lower link end lift capacity W_0
 Implement weight The implement weight which can be put on the links : W_1
 Trailer loading weight The max. loading weight for trailer (without trailer's weight) : W_2

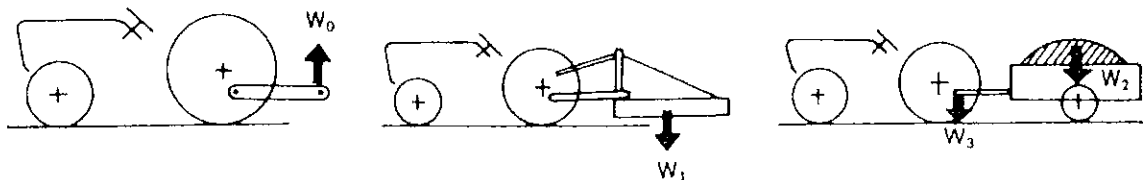

No.	Implement	Remarks	L2250	L2550	L2850	L3250	
1	Trailer	Max. Load Capacity kg (lbs.)	1000 (2200)	1500 (3300)	2000 (4400)	2500 (5500)	
		Max. Drawbar Load kg (lbs.)	300 (730)	500 (1100)	650 (1430)	650 (1430)	
2	Mid Mount	Max. Cutting Width mm (in.)	1829 (72)	1829 (72)	1829 (72)	—	
		Max. Weight kg (lbs.)	200 (440)	200 (440)	200 (440)	—	
		Rear Mount	Max. Cutting Width mm (in.)	1829 (72)	1829 (72)	1829 (72)	1829 (72)
			Max. Weight kg (lbs.)	350 (770)	350 (770)	350 (770)	400 (880)
	Flail Mower	Max. Cutting Width mm (in.)	1270 (50)	1524 (60)	1524 (60)	1524 (60)	
		Max. Weight kg (lbs.)	350 (770)	400 (880)	400 (880)	400 (880)	
	Sickle Bar	Max. Cutting Width mm (in.)	1829 (72)	2133 (84)	2133 (84)	2133 (84)	
		Max. Weight kg (lbs.)	400 (880)	500 (1100)	500 (1100)	500 (1100)	
3	Sprayer	Max. Tank-capacity ℓ (gals.)	Rear mounted	300 (80)	300 (80)	400 (106)	400 (106)
			Pull type	800 (210)	800 (210)	1000 (264)	1200 (317)
4	Rotary Tiller	Max. Tilling Width mm (in.)	1370 (54)	1520 (60)	1520 (60)	1520 (60)	
5	Bottom Plow	Max. Size	12in.X2, 16in.X1	12in.X2, 16in.X1	14in.X2	14in.X2	
6	Disc-harrow (Pull type)	Max. Harrowing Width mm (in.)	1524 (60)	1829 (72)	1829 (72)	1981 (78)	
		Max. Weight kg (lbs.)	300 (660)	350 (770)	350 (770)	400 (880)	
7	Chisel Plow	Max. Cutting Width mm (in.)	1829 (72)	1829 (72)	1829 (72)	1829 (72)	
		Max. Weight kg (lbs.)	350 (770)	350 (770)	350 (770)	350 (770)	
8	Broad Caster	Max. Tank Capacity ℓ (gals.)	200 (53)	200 (53)	250 (66)	300 (80)	
		Max. Wight kg (lbs.)	100 (220)	100 (220)	100 (220)	100 (220)	
9	Manure Spreader	Max. Capacity kg (lbs.)	1000 (2200)	1500 (3300)	2000 (4400)	2000 (4400)	
10	Cultivator	Max. Width mm (in.)	1524 (60)	1829 (72)	2134 (84)	2134 (84)	
		Number of Rows	1	1	2	2	
		Max. Weight kg (lbs.)	250 (550)	300 (660)	350 (770)	400 (880)	
11	Front Blade	Max. Cutting Width mm (in.)	1829 (72)	1829 (72)	1829 (72)	1829 (72)	
		Max. Oil Pressure kgf/cm ² (psi.)	150 (2130)	150 (2130)	150 (2130)	160 (2275)	
		Sub Frame	Necessary	Necessary	Necessary	Necessary	
12	Rear Blade	Max. Cutting Width mm (in.)	1829 (72)	1829 (72)	1829 (72)	1829 (72)	
		Max. Oil Pressure kgf/cm ² (psi.)	150 (2130)	150 (2130)	150 (2130)	160 (2275)	
13	Front-end Loader	Max. Lifting Capacity kgf (lbs.)	400 (880)	400 (880)	500 (1100)	550 (1210)	
		Max. Oil Pressure (Extra Hydro Kit) kgf/cm ² (psi.)	150 (2130)	150 (2130)	150 (2130)	160 (2275)	
		Sub Frame	Necessary	Necessary	Necessary	Necessary	
14	Box Blade	Max. Cutting Width mm (in.)	1321 (52)	1321 (52)	1651 (65)	1670 (66)	
		Max. Weight kg (lbs.)	295 (650)	295 (650)	330 (730)	350 (770)	
15	Back Hoe	Max. Digging Depth mm (in.)	2288 (90)	2288 (90)	2288 (90)	2288 (90)	
		Max. Weight kg (lbs.)	450 (990)	450 (990)	450 (990)	450 (990)	
		Sub Frame	Necessary	Necessary	Necessary	Necessary	
16	Snow Blade	Max. Width mm (in.)	1524 (60)	1524 (60)	1524 (60)	1830 (72)	
		Max. Weight kg (lbs.)	300 (660)	300 (660)	300 (660)	350 (770)	
17	Snow Blower	Max. Working Width mm (in.)	1524 (60)	1524 (60)	1676 (66)	1676 (66)	
		Max. Weight kg (lbs.)	250 (550)	250 (550)	280 (620)	280 (620)	

4. OPERATING NEW TRACTOR

How a new tractor is handled and maintained determines the life of the tractor.

A new tractor just off the factory production line has been, of course, well fitted and tested, but the various parts are not accustomed to strenuous types of work, so care should be taken to operate the tractor for the first 100 hours at a lower speed and avoid excessive work or operation until the various parts become well "broken-in." The manner in which the tractor is operated during the "breaking-in" period greatly affects the life of your tractor. Therefore, to obtain the maximum performance and the longest life of the tractor, it is very important to properly break-in your tractor.

In operating a new tractor, the following precautions should be observed.

■ Do not Operate the Tractor at Full Speed for the First 100 Hours.

- Do not start quickly nor apply the brakes suddenly.
- In winter, operate the tractor only after fully warming up the engine.
- Do not run the engine at speeds faster than necessary.
- On rough roads, slow down to suitable speeds. Do not operate the tractor at fast speed.

The above precautions are not limited only to new tractors, but to all tractors. But it should be especially observed in the case of new tractors.

■ Changing Lubricating Oil for New Tractors

The lubricating oil is especially important in the case of a new tractor. The various parts are not "broken-in" and are not accustomed to each other; small metal grit may develop during the operation of the tractor; and this may wear out or damage the parts. Therefore, care should be taken to change the lubricating oil a little earlier than would ordinarily be required.

For further details of change interval hours, see check list. (See page 39)

■ Read "Safe Operation"

Please read "Safe Operation" before attempting to start or operate the tractor.

4.1 LOADING AND UNLOADING

- (1) When loading (or unloading) a tractor onto a truck or trailer, check the truck or trailer's tires.
- (2) Securely fix a rugged ramp with non-skids to the truck or trailer bed and check to see that there are no people around before starting to load or unload the tractor.
- (3) Back the tractor when going up the ramp.

5. INSTRUMENT PANEL AND CONTROLS

5.1 SWITCHES

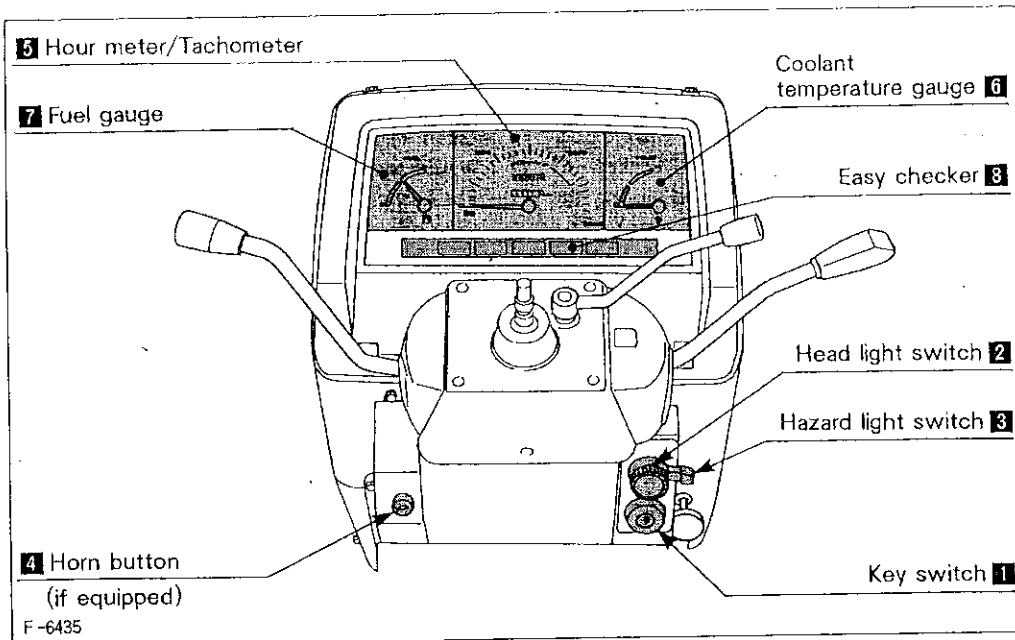

1 Key Switch

- ⚡ OFF..... The position where the key can be inserted into or removed from the key switch. [The engine stops the moment the key is turned to this position.(if equipped)]
- ⚡ ON..... The engine keeps running.
- 🔥 Preheat..... The combustion chamber is heated.
- 🌀 Start..... Depress the clutch pedal fully and turn the key switch to this position to start the engine.

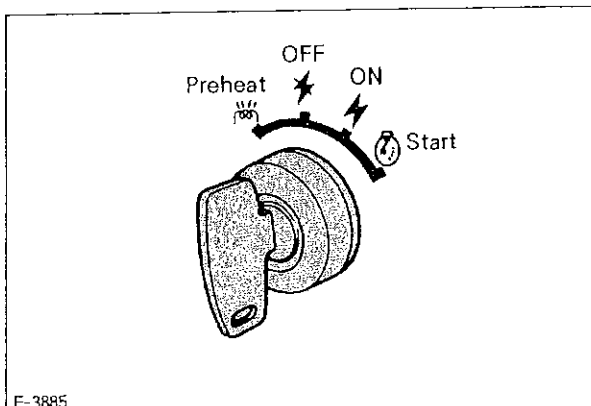

IMPORTANT:

- Because of the safety device, the engine may not be started except when the clutch is disengaged.

2 Head Light Switch

- ☞ Head lights ON, high beam.
- ☞ Head lights dimmed, low beam.
- OFF..... Head lights OFF.

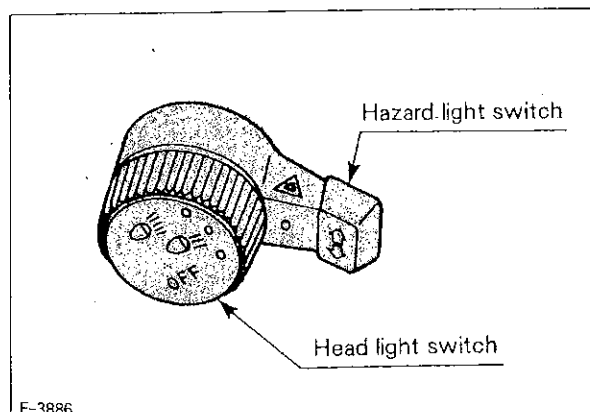

3 Hazard Light Switch (if equipped)

- When hazard light switch is turned to either direction, the hazard lights blink.
- (Hazard light is standard for USA)

4 Horn Button (if equipped)

- The horn will sound when the key switch is in the ON position.

5 Hour Meter/Tachometer

This meter gives readings for engine speed, PTO shaft speed and the hours the tractor has been operated.

- (1) The indicator shows the engine speed and corresponding PTO shaft speed.
- (2) The hour meter indicates in five digits the hours the tractor has been used; the last digit indicates 1/10 of an hour.

6 Coolant Temperature Gauge

- (1) With the key switch at "ON," this gauge indicates the temperature of the coolant. "C" for "cold" and "H" for "hot".
- (2) If the indicator reaches the "H" setting (red zone), coolant is overheated. Check the tractor by referring to "Coolant" on page 46.

7 Fuel Gauge

- The fuel gauge indicates the amount of fuel.

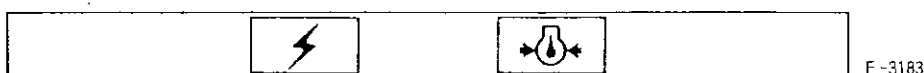



8 Easy Checker

F-3183

(if equipped)



F-3183改

-  Alarm for when the air cleaner is clogged.
-  Alarm for when the battery electrolyte level drops. Lights up when the electrolyte level drops to the "LOW LEVEL."
-  Alarm for when the coolant level drops in the coolant recovery reservoir.
-  Alarm for when the electrical charge system is not functioning properly.
-  Alarm for when the engine oil pressure is low.

◆ How to check the Easy Checker

- (1) When the key switch is turned "ON," all the lights should come on. When the engine starts up, all the lights should go off.
- (2) If trouble should occur at any location while the engine is running, the alarm light corresponding to that location comes on.

IMPORTANT:

- Daily checks with the Easy Checker only, are not sufficient. Always conduct daily checks carefully by referring to "Daily Checks." See page 37.

Instrument panel

- 1 – key switch
- 2- combined switch
- 3- light
- 4- klaxon / horn
- 5- hour meter/tachometer
- 6- fuel gauge
- 7- water thermometer
- 8- control lights

Controls

- 7- main speed lever (except GST model)
- 9- multiple lever (except GST model)
- 10-shuttle shift lever (reverse drive)
- 11- throttle lever
- 12- throttle pedal
- 13- engine stop button
- 14- clutch pedal
- 15- brake pedal
- 16- parking brake

17-PTO speed lever

18-Front wheel drive connection lever

19-seat lever

20- command lever

21- stop lever

22—

23- height lever

24- MONROE box (rear hydraulic)

25- MONROE manual switch

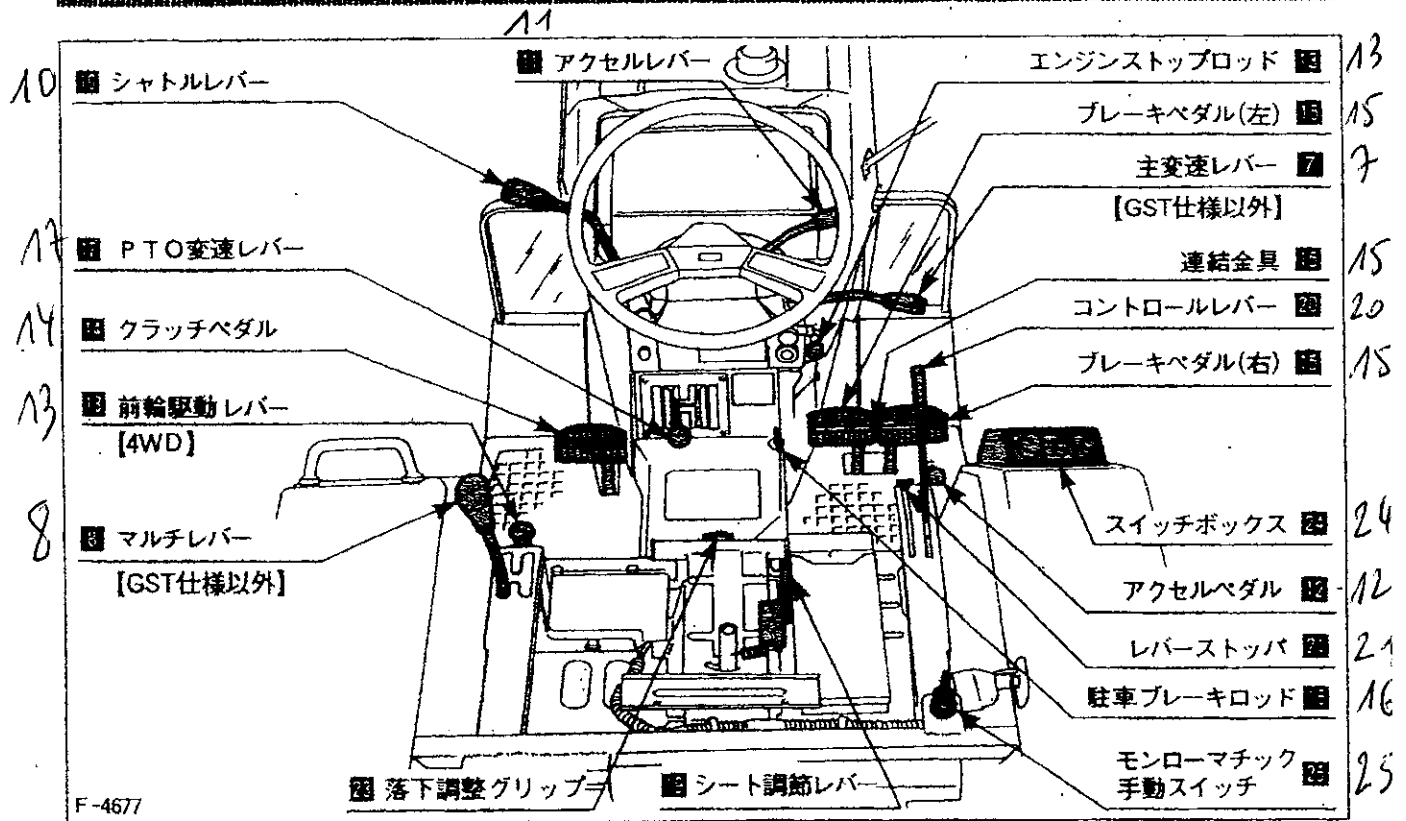
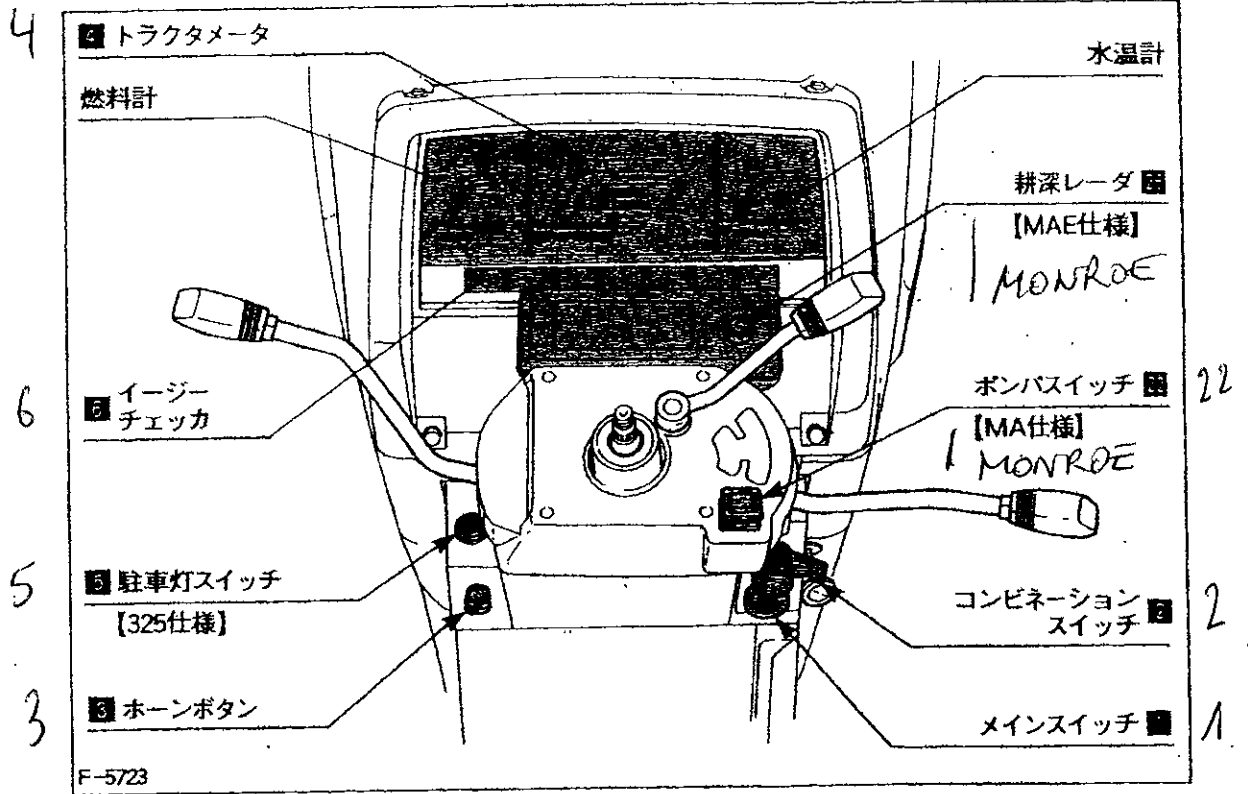

Multi speed lever (non GST model)

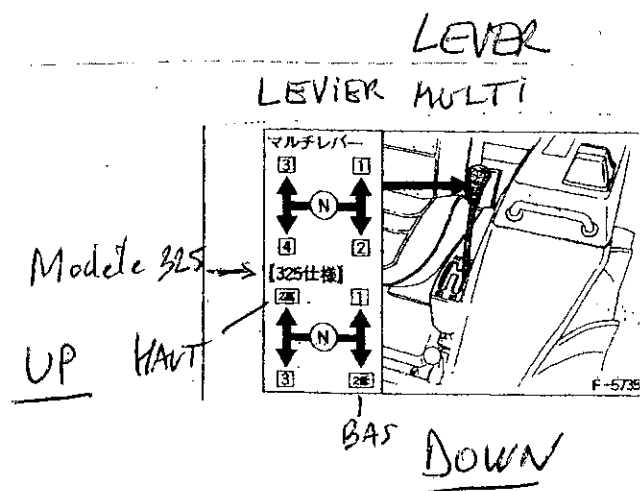
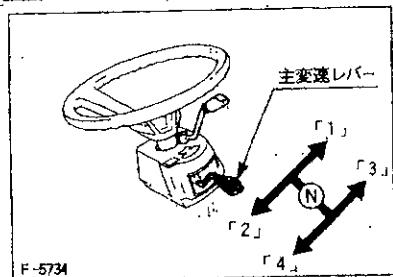
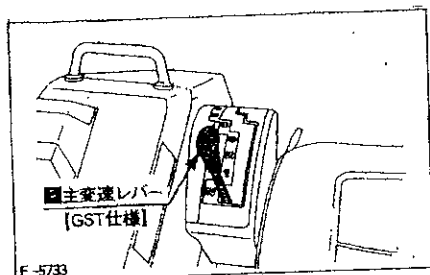

Combined with the main lever (at steering wheel), you get 16 speeds forward and backwards. The positions 1 and 2 (2 slow) are creeping speeds.

Attention :

^{be} It could difficult to manipulate the lever. In that case, push again the clutch pedal and repeat.

If the difficulty remains, disregard the main lever (at steering wheel) or the « shuttle » lever , by positioning on « N » position, and start again with the lever.

PTO speed lever

All models except X model :

There are 4 speeds on the PTO.

The speeds « 1 » and « 3 » work only with double clutch.

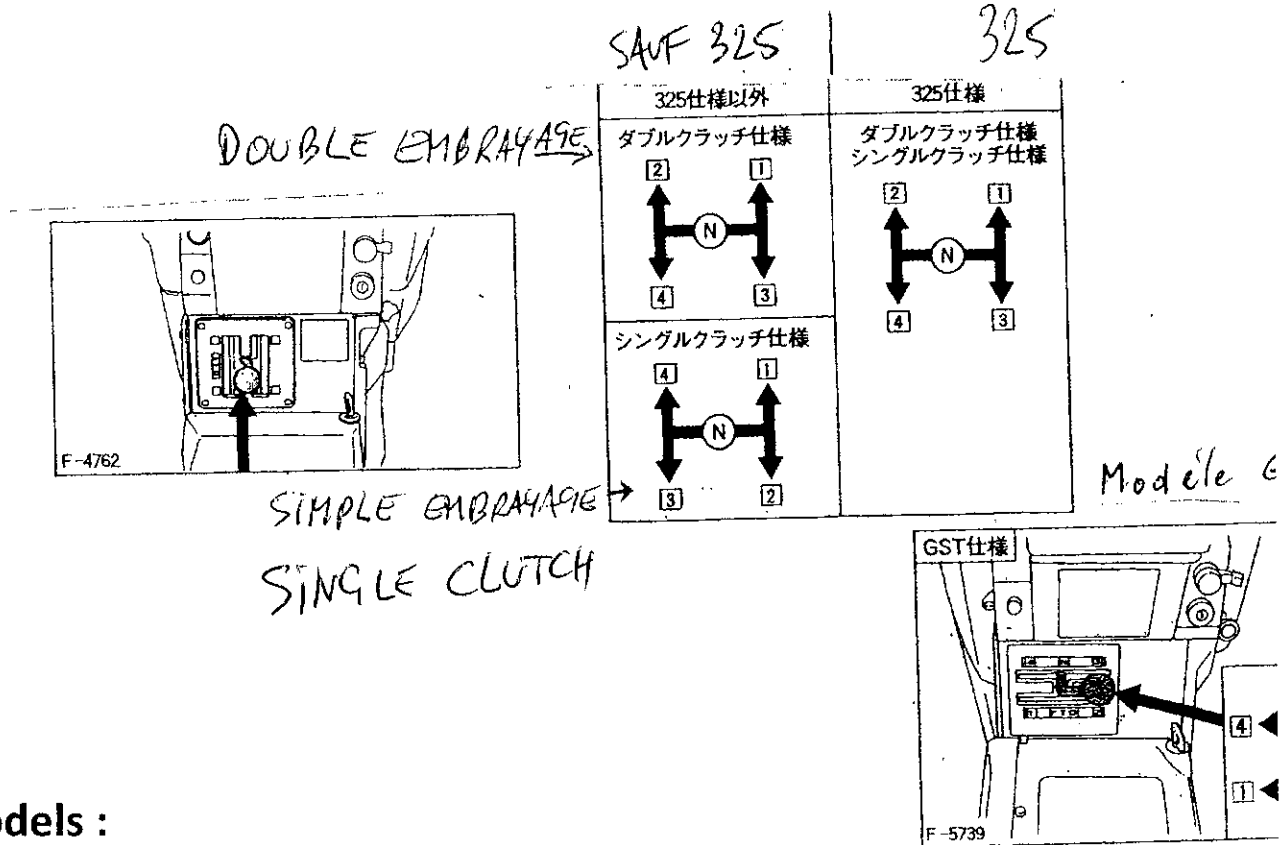

X models :

There are 4 speeds clockwise and one speed counter clockwise (links).

You may engage the counterclockwise speed (reverse) only when the connection lever is in neutral position.

When you change from the reverse rotation to the clockwise rotation, the connection lever comes automatically on the neutral position.

x
DISCONNECTED
Débrayé

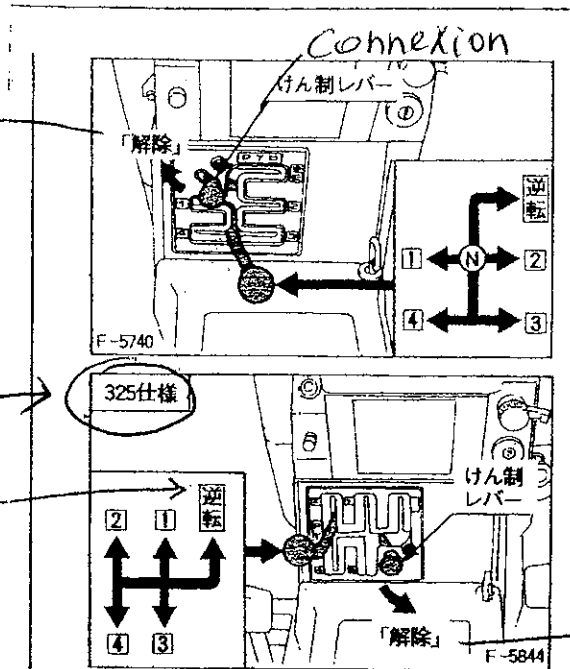

REVERSE
INVERSE

INVERSE
REVERSE

Débrayé
DISCONNECTED

Use of the reverse PTO

The attachment must accept to run in reverse direction !

Otherwise, many damages are possible. It is possible with a tiller, for example, as you can remove a mount of soil.

Front wheels traction lever

This lever allows the connection of the front wheels traction :

Only possible when the clutch pedal is pressed .

Lever forwards : the wheels are in action/traction

Lever backwards : front traction not active.

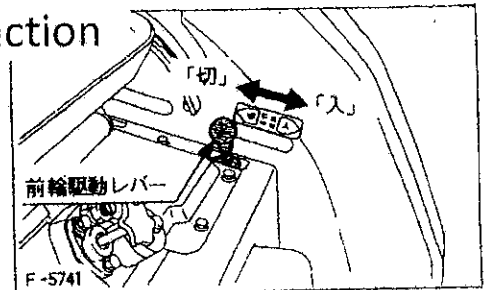

Use of the front wheels traction

Use it only when a high traction power is necessary.

Double speed lever (B model)

This lever enable you to stop the front traction.

When this lever is pushed downwards, the tractor runs with 2 wheels drive continuously.

When the lever-lock is on neutral position and this lever is pushed downwards, the tractor runs with 4WD.

When the lever is pulled upwards, the tractor runs in double-speeds.

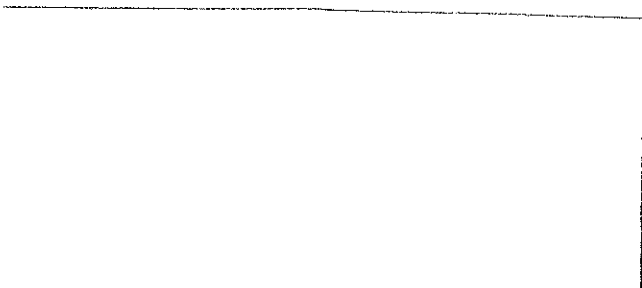

use of double speeds lever

usefull for tilling and ploughing work.

Any misuse is dangerous !

Use it only when the front wheels are directed forward.

Don't use it with front weights or front end loader or high speed of engine.

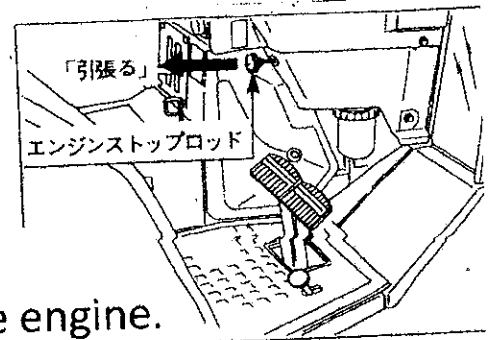

Engine stop

By pulling on the engine pull tab, you stop the engine.

After the stop of the engine, you have to push back the tab in its original position. The return is not automatic.

If the button/tab is not pushed/pressed, it is impossible to start the engine.

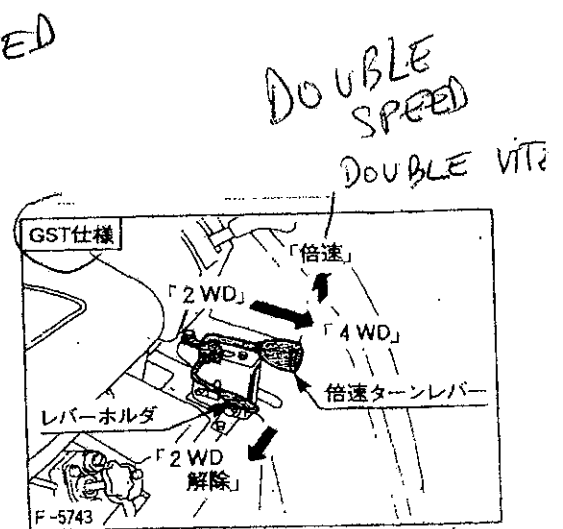
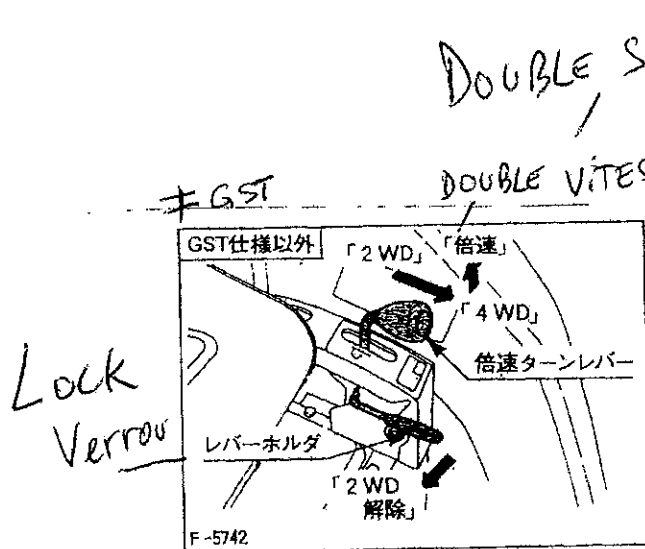

When turn the ignition key on « OFF »,the engine stops.

If the engine doesn't stop as mentionned, please pull the tab.

Clutch pedal

Single clutch :

Pedal pressed = clutch disc not connected

Pedal released = clutch is engaged.

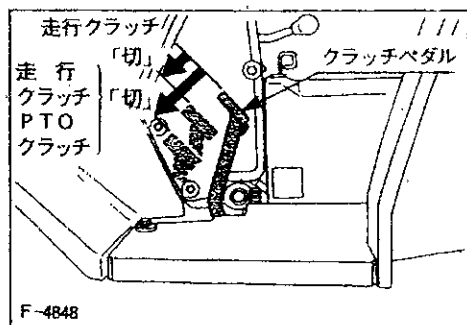

Double clutch :

Pedal pressed by one stage :: the drive clutch is decoupled, but the PTO clutch is engaged.

Pedal pressed by two stages : both drive and PTO are disconnected.

Pedal released (free) : both drive and PTO are connected.

5.2 CONTROLS

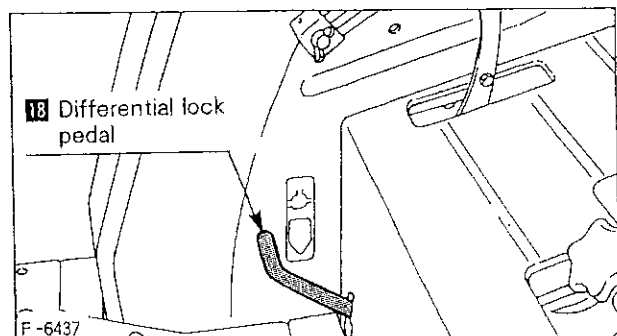
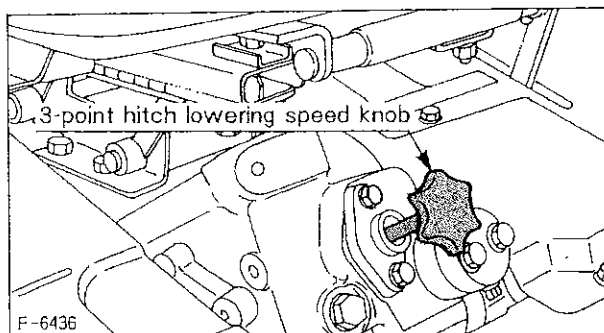
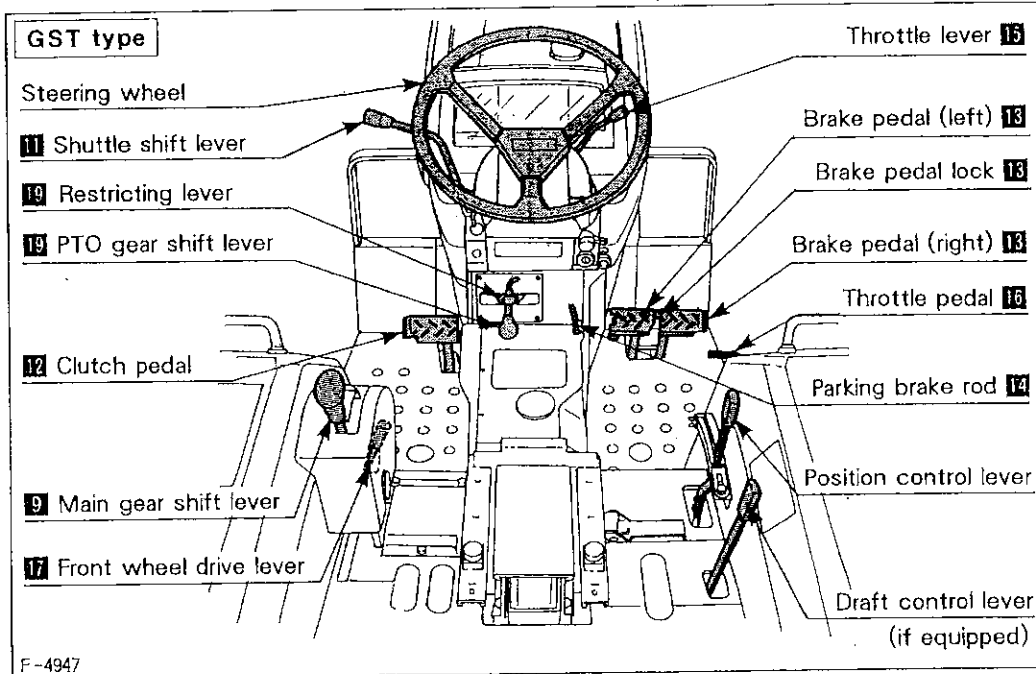
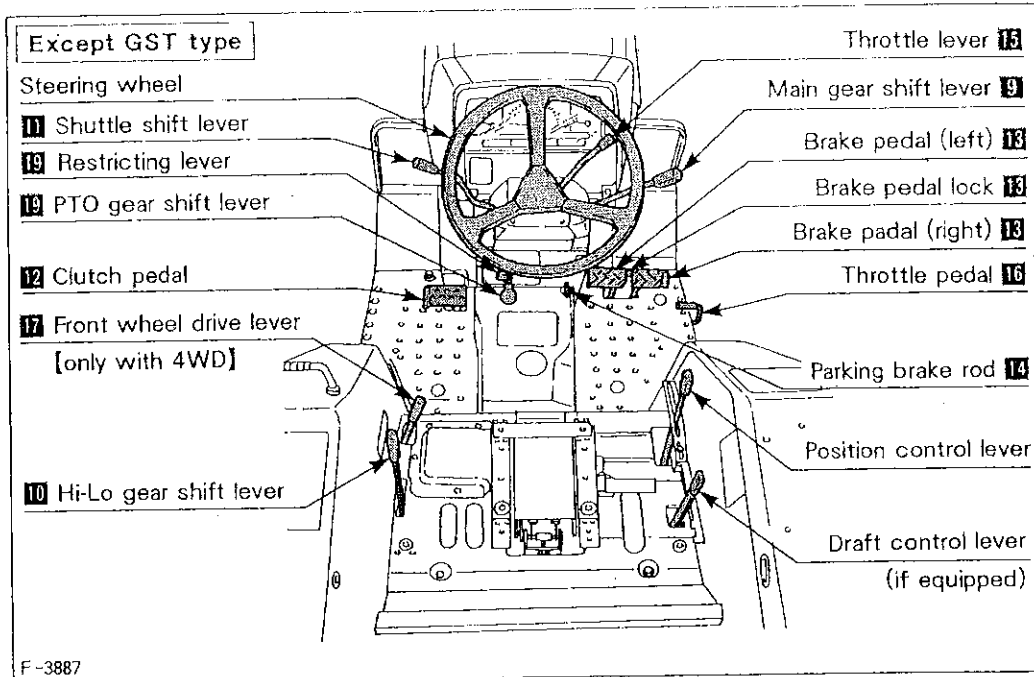

910 Main Gear Shift Lever & Hi-Lo Gear Shift Lever [Except GST type]

Main gear shift lever pattern is in the form of an "H". Hi-Lo gear shift lever moves two stages, "High" and "Low". By combination and use of the main gear shift lever and the Hi-Lo gear shift lever, eight speeds are obtained.

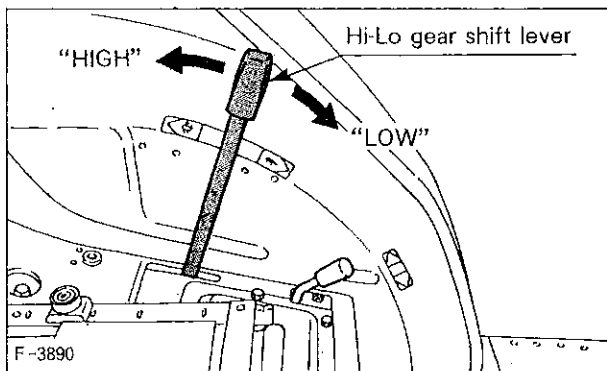
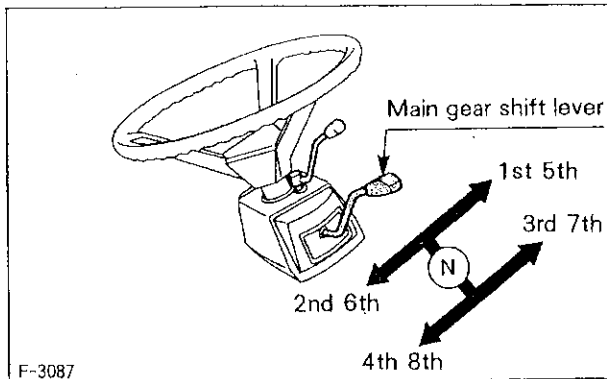

11 Shuttle Shift Lever [Except GST type]

Shift the shuttle lever forward to obtain forward speeds and shift it back to obtain reverse speeds. There are a total of eight forward and eight reverse speeds.

IMPORTANT:

- Reduce engine speed to low idle before shifting the shuttle shift lever.
- Press the clutch pedal completely down and stop the tractor's motion before shifting the shuttle shift lever.
- Before shifting the main gear shift lever or the Hi-Lo gear shift lever, fully disengage the clutch and completely stop the tractor.
- If the tractor is equipped with the partially synchronized transmission, shifting on the go between 3rd and 4th speeds and 7th and 8th speeds may be done by depressing the clutch and shifting. Coming to a complete stop is not necessary.



WARNING

To avoid personal injury:

BEFORE DISMOUNTING TRACTOR

- **ALWAYS SET PARKING BRAKE**
Leaving transmission in gear with the engine stopped will not prevent tractor with shuttle transmission from rolling.
- **LOCK SHUTTLE SHIFT LEVER IN NEUTRAL POSITION**
This prevents movement of shuttle shift lever out of neutral position.
- **STOP THE ENGINE AND REMOVE THE KEY**

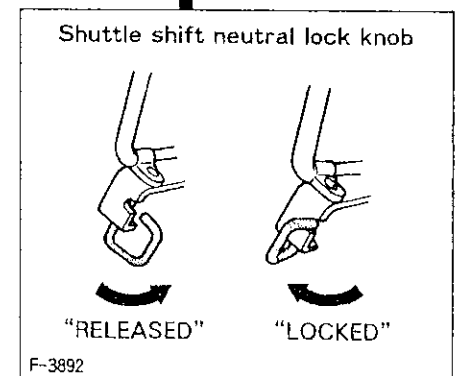
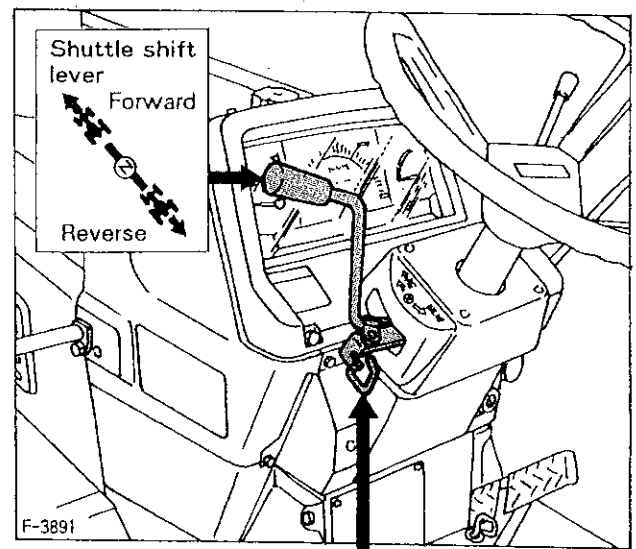

9 Main Gear Shift Lever [GST type]

Main gear shift lever has NINE positions, neutral and 1st thru 8th gear. Main gear shift lever pattern is shown in the following illustration.

With the Glide Shift Transmission, you can shift at any time, stopped or on-the-go. The Shuttle Shift lever must be in forward or reverse.

There is no need to use the clutch when starting out or shifting up or down.

"Live" PTO operation can be obtained with Glide Shift Transmission tractors. Depress clutch and move PTO gear shift lever to 540 or 1000 rpm. Release the clutch and the PTO will be engaged. Move Shuttle Shift lever to forward or reverse. Forward or Reverse movement can now be obtained with the main gear shift lever. To stop the tractor movement without disengaging PTO, shift main gear shift lever to neutral or move shuttle shift lever to neutral and set parking brake.

And the PTO continues running even if you change the traveling speed or stop the tractor.

Before dismounting tractor, shift the main gear shift lever to the neutral position and set parking brake.

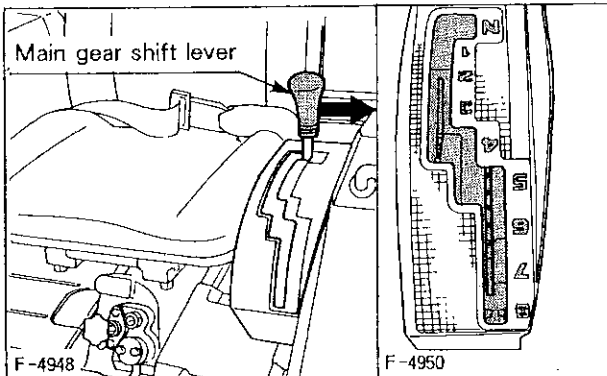

IMPORTANT:

- Start in lower gears and shift one gear at a time until desired gear is obtained.
- To prolong clutch life, avoid slipping the hydraulic clutch. Pay attention to the following points:
 - Select proper gear and engine speeds depending on the type of job.
 - Avoid operating the tractor in higher gears which cause excessive engine lugging.



CAUTION

To avoid personal injury:

- Use the clutch when making an emergency stop or working in confined areas, such as getting tractor in position to attach an implement.
- An accident may occur with erratic shift operation.

For safe operation, move main gear shift lever only one gear at a time. On rough ground, use balustrade to steady hand.

- Shift the main gear shift lever firmly and without hesitation. Improper shift lever position will cause the tractor to momentarily coast on slopes.

- Before descending a hill, shift to a gear low enough to control tractor speed without using brakes.

If you change the speed descending a hill, use the brakes during that operation to keep control of the vehicle.

- Operate in reverse at slow speeds to maintain control.

11 Shuttle Shift Lever [GST type]

Move the shuttle shift lever forward to obtain forward speeds and move it rearward to obtain reverse speeds without using the clutch pedal.

Total of eight forward and eight reverse speeds can be obtained.

Tractor with glide shift transmission can obtain live PTO by moving shuttle shift lever to neutral position.

IMPORTANT:

- Reduce engine speed to low idle before shifting the shuttle shift lever.
- Shuttle shift change should not be done at a time. Move the shuttle shift lever to the neutral position momentarily before you accomplish the shuttle change.



WARNING

To avoid personal injury:

BEFORE DISMOUNTING TRACTOR:

- ALWAYS SET PARKING BRAKE
Leaving transmission in gear with the engine stopped will not prevent tractor with shuttle transmission from rolling.
- LOCK SHUTTLE SHIFT LEVER IN NEUTRAL POSITION
This prevents movement of shuttle shift lever out of neutral position.
- STOP THE ENGINE AND REMOVE THE KEY

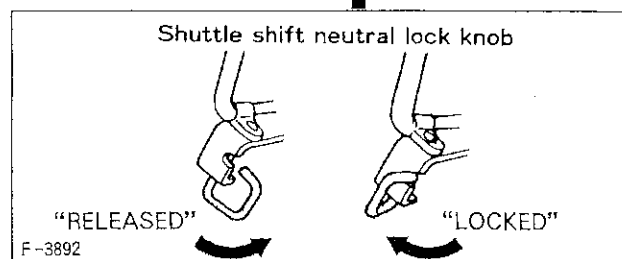
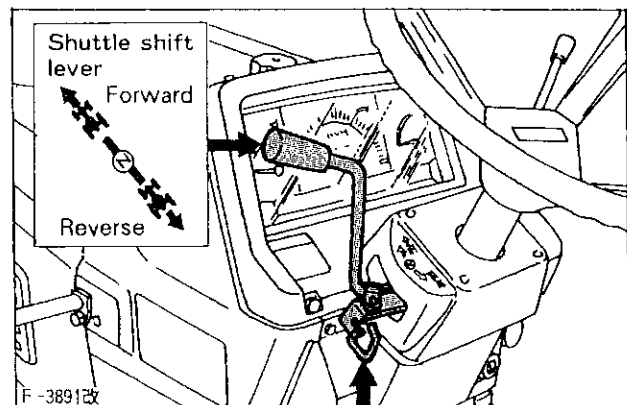

12 Clutch Pedal [with Single Clutch, with GST]

The clutch is disengaged when the clutch pedal is fully pressed down.

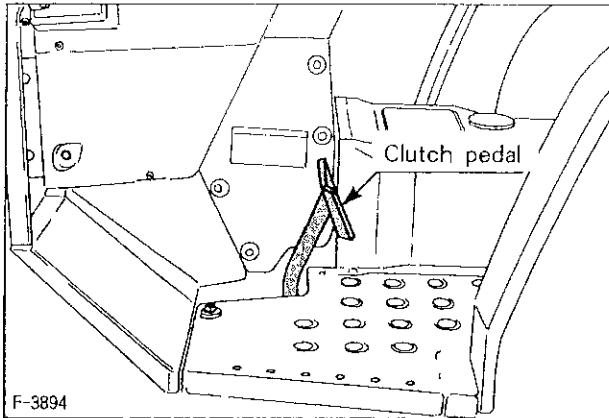

12 Clutch Pedal [with Dual Clutch]

The transmission clutch is disengaged when the clutch pedal is pressed down half-way (A). The PTO clutch remains engaged. Both transmission and PTO clutch are disengaged when the pedal is fully pressed down (B).

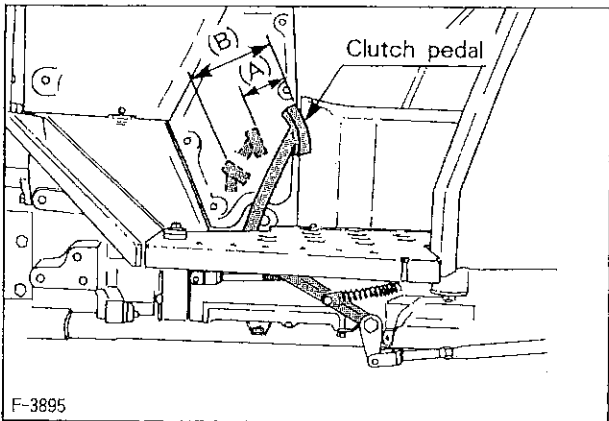

IMPORTANT:

- The clutch pedal must be quickly disengaged and be slowly engaged.
- Never operate the tractor with your foot resting on the clutch pedal. Doing so may contribute to premature clutch wear.
- While the tractor is traveling on a road, or when PTO power is not used, place the PTO gear shift lever in neutral.

13 Brake Pedals [Right and Left]



WARNING

To avoid personal injury:

- Applying only one rear wheel brake at high speeds could cause the tractor to swerve or roll-over.

- (1) Before operating the tractor on the road, be sure to interlock the right and left pedals as illustrated below.
- (2) Use individual brakes to assist in making sharp turns at slow speeds (Field Operation Only). Disengage the brake pedal lock and depress only one brake pedal to do this.

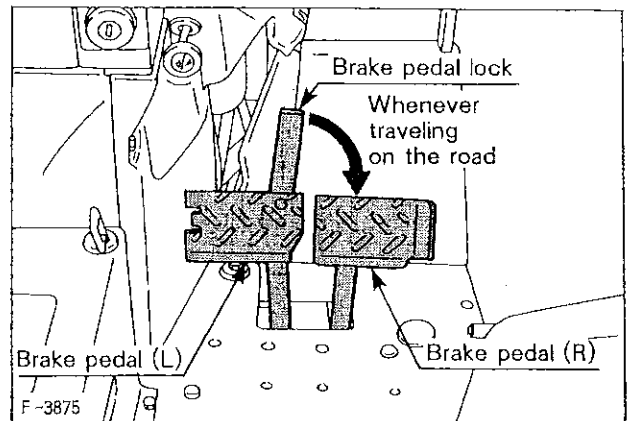

14 Parking Brake Rod

- (1) To set the parking brake;
 - Interlock the brake pedals.
 - Depress the brake pedals.
 - Latch the brake pedals with the parking brake rod.
- (2) To release the parking brake, depress the brake pedals again.

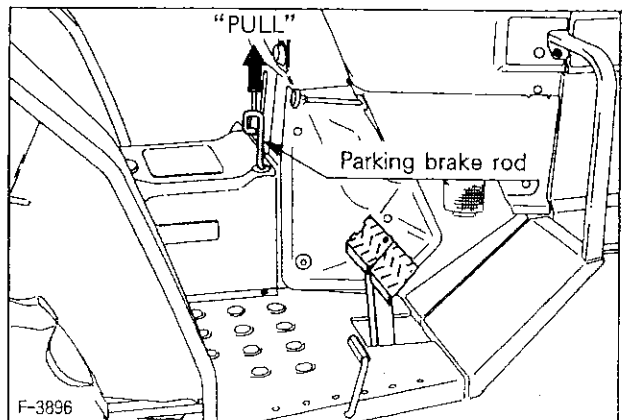

IMPORTANT:

- Be sure to release the parking brake before attempting to move the tractor.

15 Throttle Lever

Pulling the throttle lever backward increases engine speed, and pushing it forward decreases engine speed.

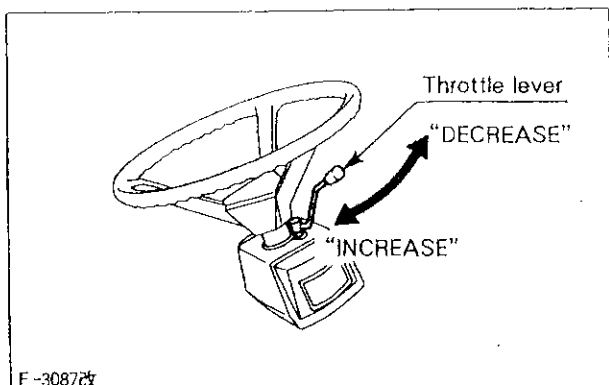

16 Throttle Pedal

Depressing the pedal increases engine speed. The throttle pedal may also be used to increase engine speed above what is set by the throttle lever.

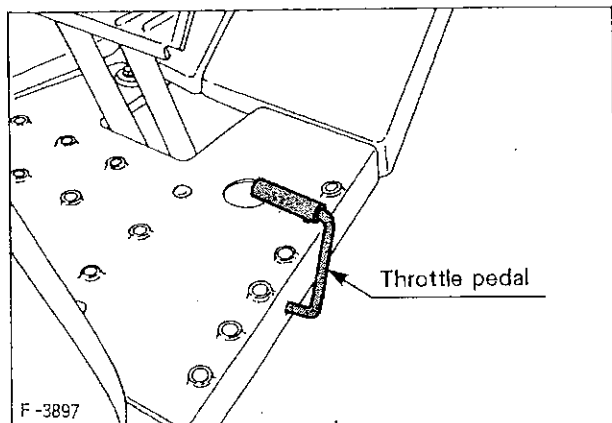

17 Engine Stop Knob [Tractor without Key Stop]

Pull engine stop knob backward and hold it until the engine stops.

18 Engine Stop Knob [Tractor with Key Stop]

The engine stops when the key switch is turned off. If the engine does not stop, pull engine stop knob back and hold it until the engine stops. After the engine has stopped, be sure to push the stop knob back in, or the engine will not start the next time.



CAUTION:

- Pull the engine stop knob back and hold it until the engine stops in case of emergency.

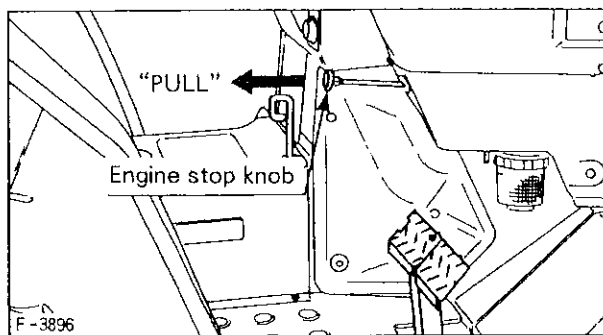

19 Front Wheel Drive Lever [4WD]

Use the lever to engage the front wheels with the tractor stopped. Shift the lever rearward to engage the front wheel drive.

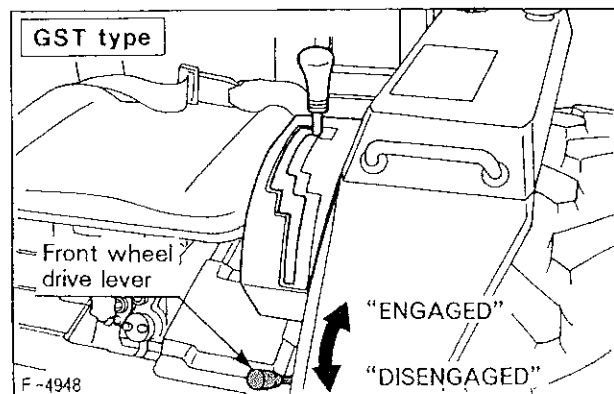
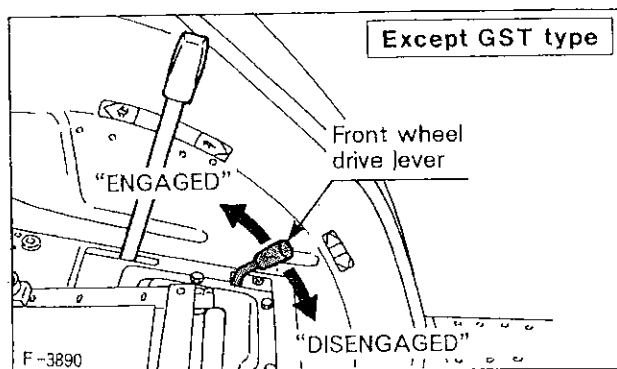

IMPORTANT:

- Depress the clutch pedal before engaging the front wheel drive lever.
- If the front wheel drive lever is difficult to disengage, turn the steering wheel in either direction, and the lever will disengage easily.

◆ Front wheel drive is effective for the following jobs:

- (1) When greater pulling force is needed, such as working in a wet field, when pulling a trailer, or when working with a front-end loader.
- (2) When working in sandy soil.
- (3) When working on a hard soil where a rotary tiller might push the tractor forward.

**CAUTION**

To avoid personal injury:

- Do not engage the front wheel drive lever while the tractor is traveling on a paved road or traveling at road speed. The tires may wear down quickly. An accident may occur if the tractor is suddenly braked.

18 Differential Lock Pedal

If one of the rear wheels should slip, step on the differential lock pedal. Both wheels will then turn together, reducing slippage.

Differential locking is maintained only while the pedal is depressed.

Refer to "Differential lock" on page 35.

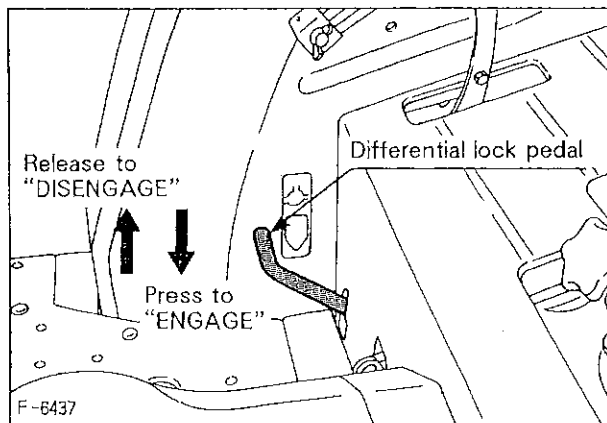
**IMPORTANT:**

- If the differential lock cannot be released in the above manner, step lightly on the brake pedals alternately.

**WARNING**

To avoid personal injury:

- It is extremely dangerous to attempt to turn the tractor to either direction with the differential lock engaged. Be sure to release the lock before making such a turn.

Operator's Seat

- (1) The operator's seat position can be adjusted forward and backward by moving the seat adjusting lever.

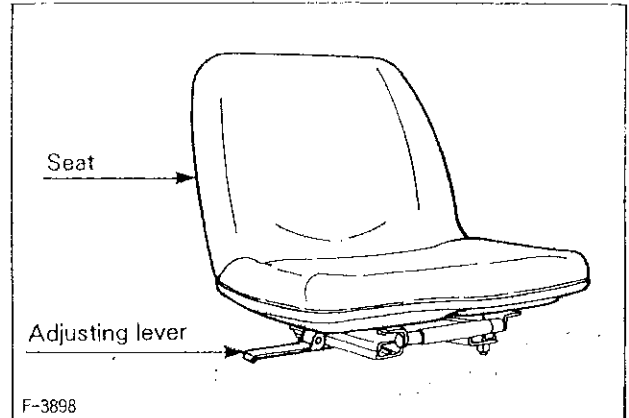
**IMPORTANT:**

- After adjusting the operator's seat forward and backward, be sure to check to see that the seat is properly locked.
- (2) Turn the bolt at the back of the seat suspension to adjust seat cushioning tension.

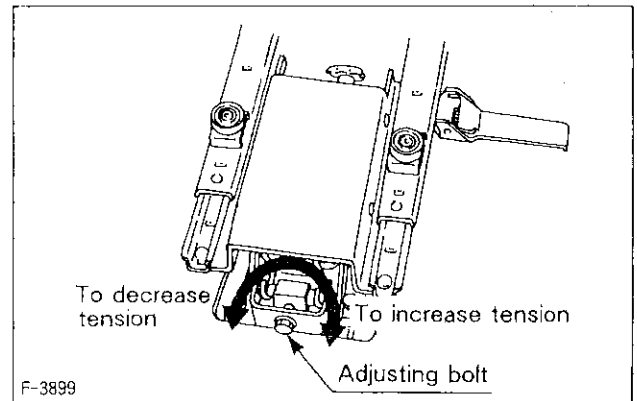
**Engine Side Shields**

Both engine side shields may be removed by turning the latch and lifting the side shield off.

**CAUTION**

To avoid personal injury:

- Never remove the engine side shields while the engine is running.

5.3 PTO OPERATION



WARNING

To avoid personal injury:

- To prevent from overspeeding a PTO driven implement and possibly causing personal injury, use the 2nd rear PTO speed (1000 rpm) and mid-PTO speed (1080 rpm, 2000 rpm) only when these higher rpms are specifically recommended by the implement manufacturer.

19 PTO Gear Shift Lever [Except L3250]

The tractor has two speeds-540 & 1000 rpm. To use PTO, pull restricting lever up and shift the lever to the right or left to desired position.

◆ Single Clutch type

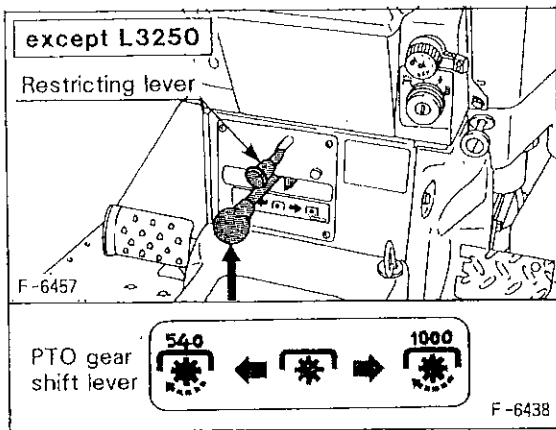

◆ Dual Clutch type

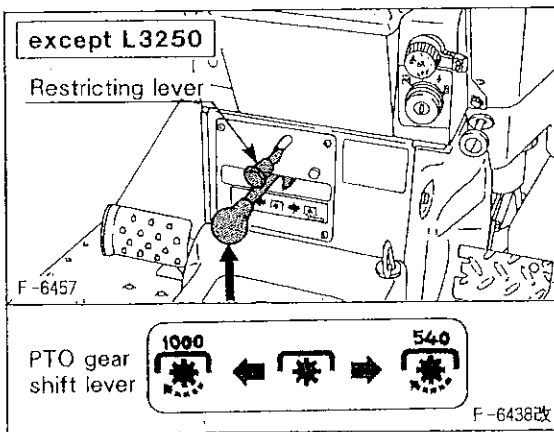

IMPORTANT:

- PTO shifting needs clutch operation. Press the clutch pedal down completely to stop the tractor movement and any PTO driven equipment movement before shifting the PTO gear shift lever.

19 PTO Gear Shift Lever [with Mid-PTO]



WARNING

To avoid personal injury:

- Do not operate rear-PTO driven implements and mid-PTO driven implements at the same time.

The tractor has two speed selections for the rear and mid-PTO.

To use PTO, pull restricting lever up and shift the lever to the right or left to desired position.

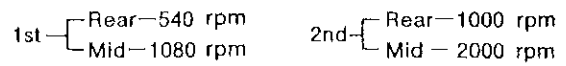

◆ Single Clutch type

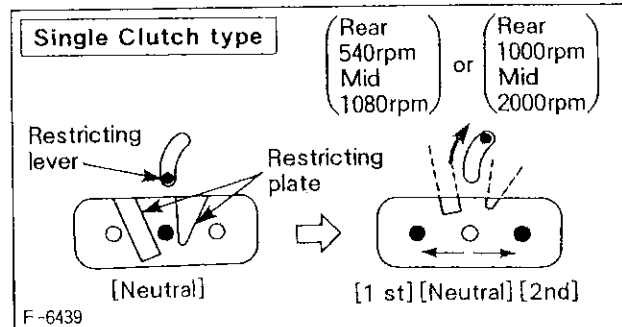

◆ Dual Clutch type

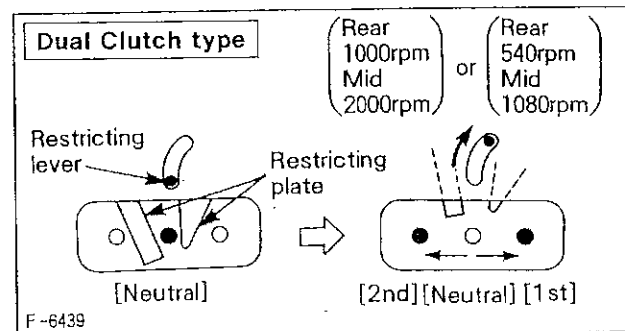

10 PTO Gear Shift Lever (L3250)

The tractor has a 540 rpm speed position and a neutral position. To use PTO, pull restricting lever up and shift the lever to the right.

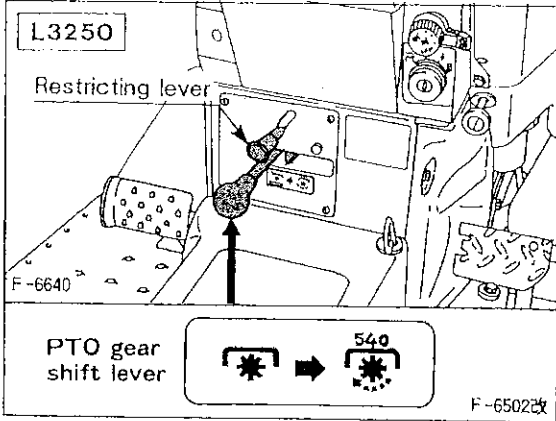

6. THREE-POINT HITCH & DRAWBAR

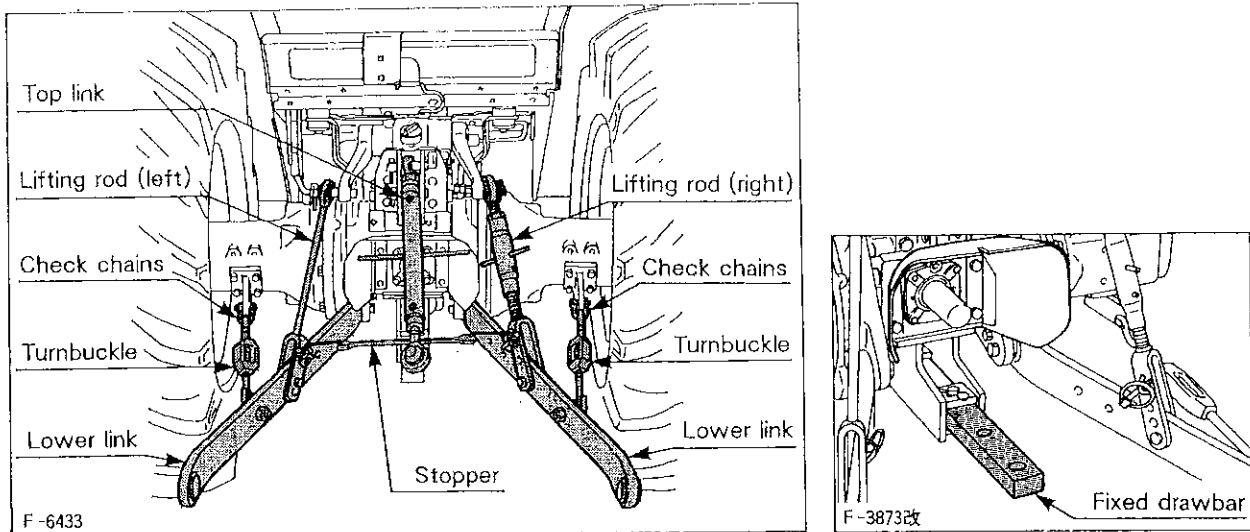

CAUTION

To avoid personal injury:

- Never pull from the top link, the rear axle or any point above the drawbar. Doing so could cause the tractor to tip over rearward causing personal injury.
- For pulling, attach to the drawbar. Use the 3-point hitch only with equipment designed for 3-point hitch usage.

■ Top Link Mounting Holes

Select the proper set of holes by referring to the "Hydraulic Control Reference Chart" on page 27.

If the hydraulic unit is set for draft control, draft response is more sensitive when an implement is connected to the upper set of top link mounting holes. If draft control is not required, it is recommended to use the low set ④.

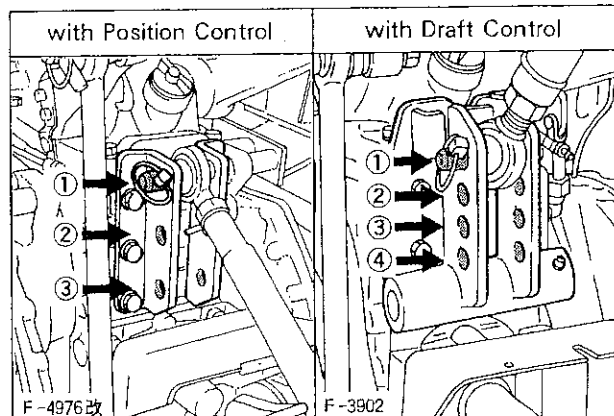

■ Adjustment of Top Link

- (1) Adjust the angle of the implement to the desired position by shortening or lengthening the top link.
- (2) The proper length of the top-link varies according to the type of implement being used.

■ Adjustment of Lifting Rod

Level a 3-point mounted implement from side to side by turning the lifting rod lever to shorten or lengthen the adjustable lifting rod.

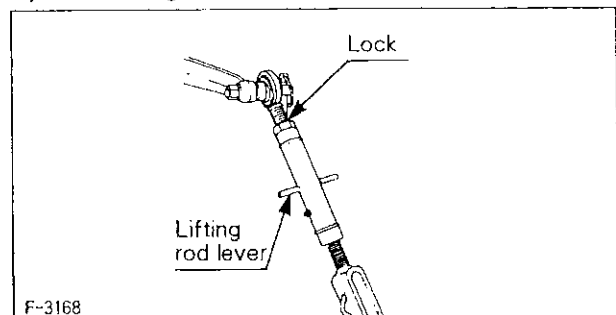

■ Adjustment of Check Chains

Adjust the turnbuckle to control horizontal sway of the implement.

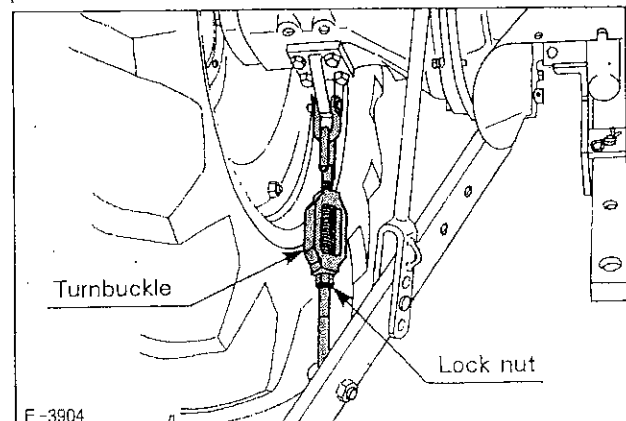

7. HYDRAULIC UNIT

The hydraulic unit consists of the lifting system which includes the hydraulic cylinder, control valve, engine driven hydraulic pump and hydraulic lines.

■ Operation

The draft control lever and position control lever controls the 3-point hitch in the following manner.

◆ Position Control

This will control the working depth of three-point hitch mounted implement regardless of the amount of pull required.

Place the draft control lever to the rear-most position and set the implement working depth with the position control lever.

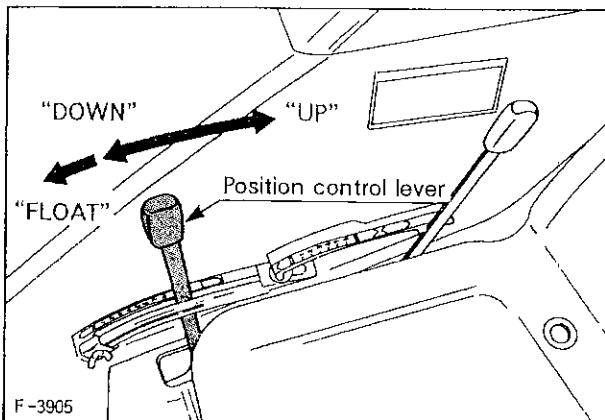

◆ Draft Control (if equipped)

This will control the pull of the three-point hitch mounted implement. As the load on the three-point hitch changes due to various soil conditions, the draft control system automatically responds to these changes by either raising or lowering the implements slightly to maintain a constant pull.

Place the position control lever to the rear-most position and set the implement pull with the draft control lever.

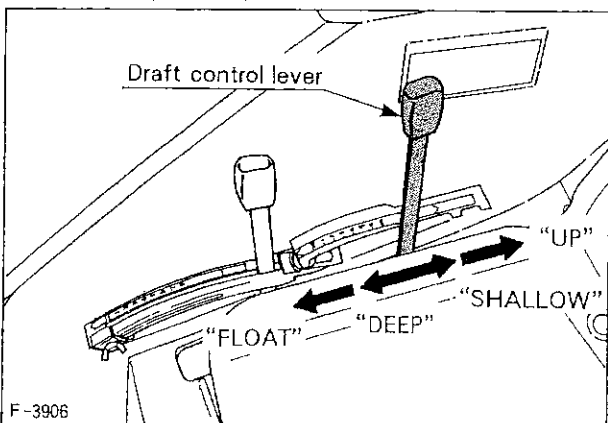

IMPORTANT:

- Do not operate until the engine is warmed up. If operation is attempted while the engine is still cold, the hydraulic system may be damaged.
- If noises are heard when the implement is lifting after the hydraulic control lever has been activated, the hydraulic mechanism is not adjusted properly. Unless corrected, the unit will be damaged. Contact your Kubota dealer for adjustment.

■ 3-Point Hitch Lowering Speed Knob

The lowering speed of the 3-point hitch can be controlled by adjusting the 3-point hitch lowering speed knob.

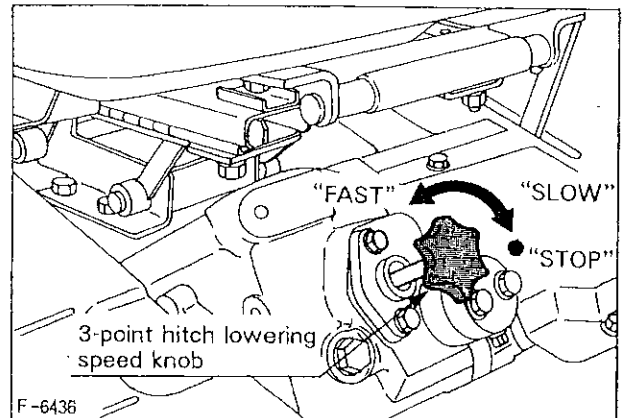

CAUTION

To avoid personal injury:

- Too fast of a lowering speed may cause damage or injury. Lowering speed of implement should be adjusted to 2 or more seconds.

Hydraulic Block type Outlet

Hydraulic block type outlet is useful when adding hydraulic operated equipment such as: front end loader, front blade, etc.

WHEN IMPLEMENT IS ATTACHED

- (1) Remove the plugs.
- (2) Route the implement inlet, outlet, and return hoses as shown in the illustration.
- (3) Move the control screw forward to "C" when implement is attached.

IMPORTANT:

- When an implement is not attached be sure the control screw is turned back against "O".

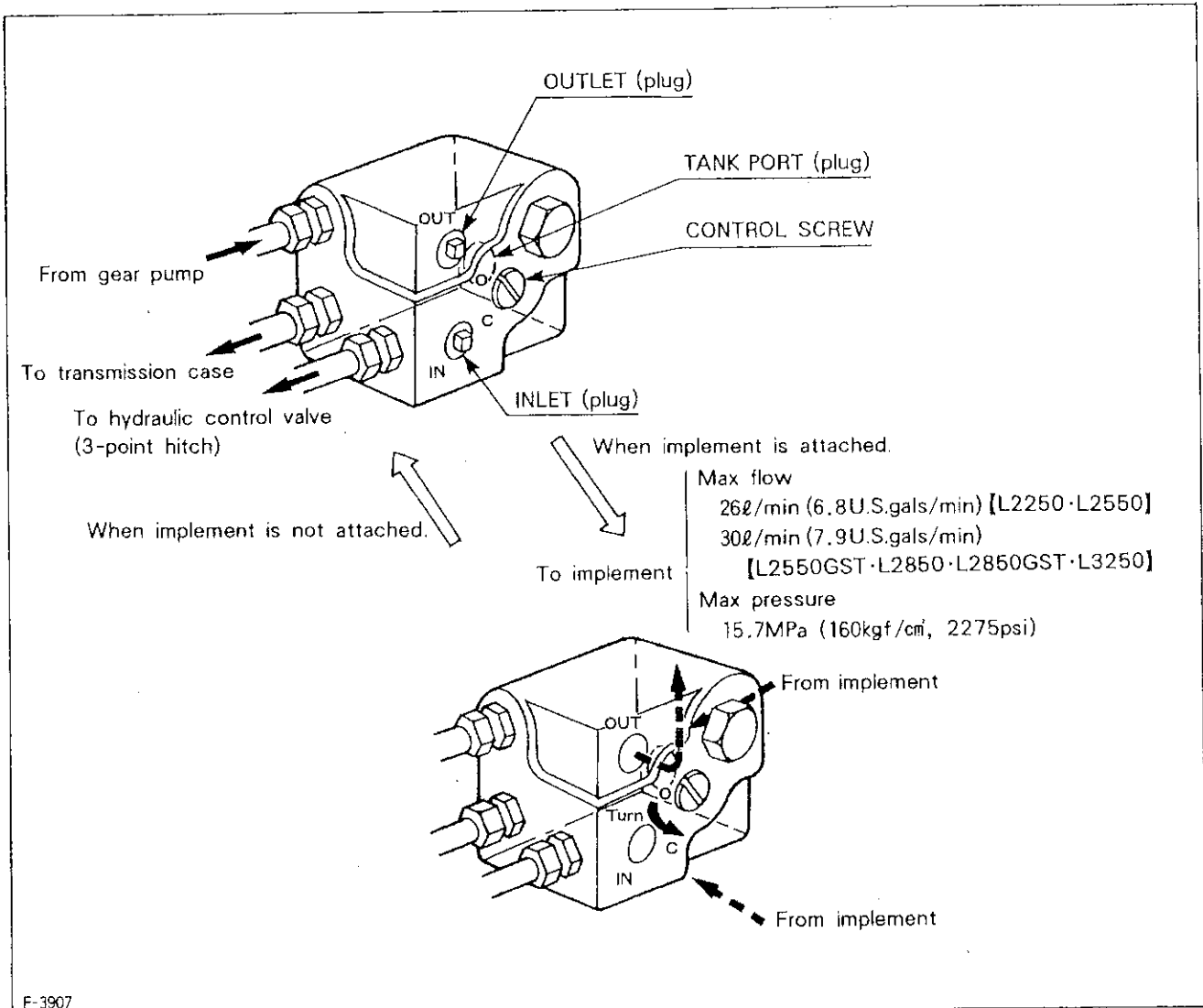

Hydraulic Control Unit Use Reference Chart

In order to handle the hydraulic unit properly, the operator must be familiar with the following. Though this information may not be applicable to all types of implements and soil conditions, it is useful for most general situations.

Implement	with Position control		with Draft control		Gauge wheel F-2016	Check chains F-3904	Remarks
	Soil condition	Position lever F-39062x Top link mounting holes	Position control lever F-39062x	Draft lever F-3906 Position control lever Draft control lever			
Moldboard plow	Light soil	1 or 2	1 or 2	Draft control (Hold the position control lever at the rear most position during operation.)	YES/NO	Loose	Adjust the check chains so that the implement can move 5 to 6 cm (2.0 to 2.4 in.) laterally. Check chains should be tight enough to prevent excessive implement movement when implement is in raised position.
	Medium soil	2 or 3	2 or 3				
	Heavy soil	3	3				
Disc plow	—	2 or 3	Position control	Position control (Hold the draft control lever at the rear most position during operation.)	YES	Tighten	With implements with gauge wheels, lower the position control lever all the way.
	—	2 or 3					
	—	3					
Harrower (spike, springtooth, disc type) Sub-soiler	—	2 or 3	Position control	Position control (Hold the draft control lever at the rear most position during operation.)	YES/NO	Tighten	With implements with gauge wheels, lower the position control lever all the way.
	—	2 or 3					
	—	3					
Weeder, ridger	—	2 or 3	Position control	Position control (Hold the draft control lever at the rear most position during operation.)	YES/NO	Tighten	With implements with gauge wheels, lower the position control lever all the way.
Earthmover, digger, scraper, manure fork, rear carrier	—	2 or 3					
Mower (mid-and rear-mount type) Hayrake, tedder	—	3					

8. WHEELS, TIRES AND BALLAST



CAUTION

To avoid personal injury:

Never operate tractor with a loose rim, wheel, or axle.

- Any time bolts and nuts are loosened, re-tighten to specified torque.
- Check all bolts and nuts frequently and keep them tight.

IMPORTANT:

- Follow the same checking procedure when tractor is first used.

Note:

- Wheels with beveled or tapered holes: Use the tapered side of lug nut.

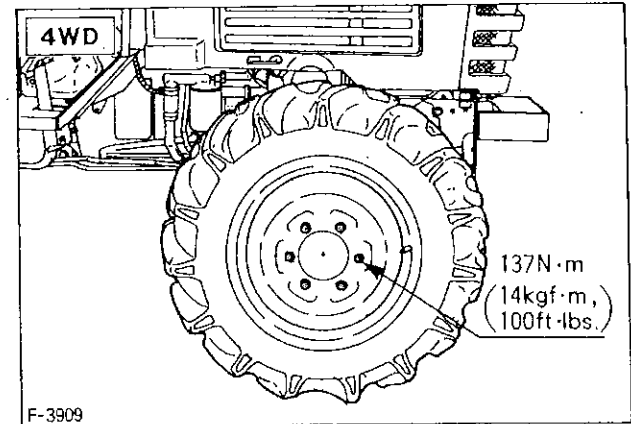
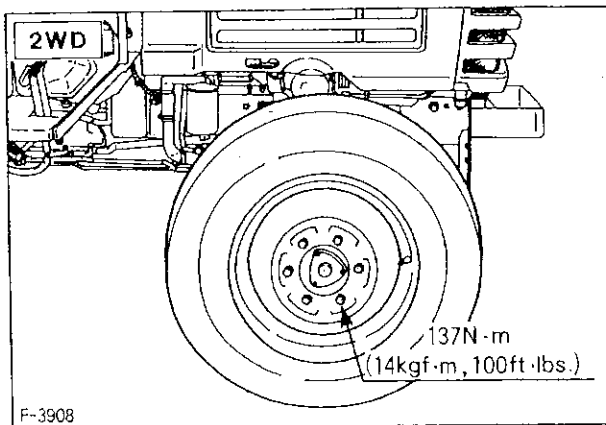
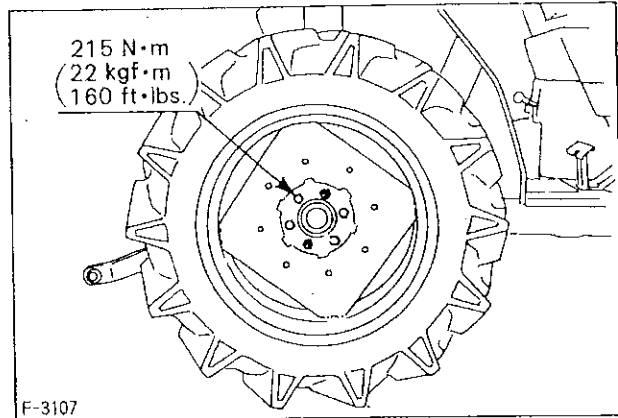
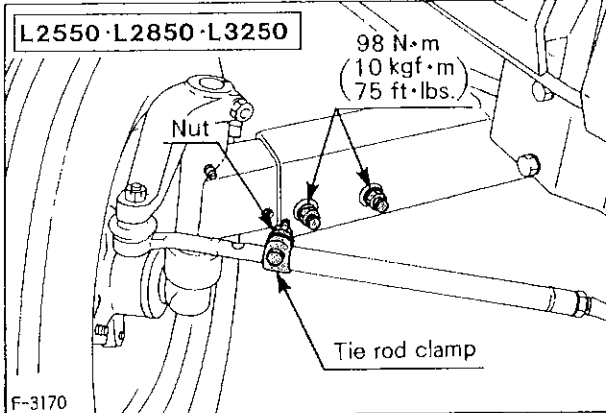
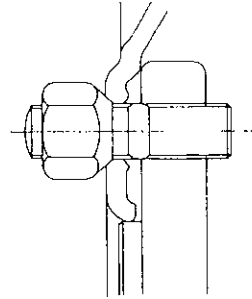

8.1 WHEEL ADJUSTMENT

Front Wheels

◆ 2WD (Two Wheel Drive)

Front tread width can be adjusted as shown with the standard equipped tires.



CAUTION

To avoid personal injury:

- When working on slopes or when working with trailer, set the wheel tread as wide as practical for the job for maximum stability.

To change the tread:

- (1) Lift the front of the tractor with a jack.
- (2) Remove the front axle mounting bolts and the tie-rod mounting bolts.
- (3) Move the front axles (right and left) to the desired position, and tighten them with bolts.
- (4) Adjust the toe-in: [2 to 8 mm (0.1 to 0.3 in.)] (See page 54)

[L2250] Front axle is not adjustable.

4.00-15 Farm	23 X 8.50-12 Turf
<p>1010mm (39.8in.)</p> <p>F-3910</p>	<p>1140mm (44.9in.)</p> <p>F-3911</p>

[L2550-L2850-L3250]

Models				
L2550 5.00-15 Farm	960 mm (37.8 in.)	1060 mm (41.7 in.)	1160 mm (45.7 in.)	1260 mm (49.6 in.)
L2550 23X8.50-12 Turf	1080 mm (42.5 in.)	1180 mm (46.5 in.)	1280 mm (50.4 in.)	1380 mm (54.3 in.)
L2850 5.00-15 Farm	1150 mm (45.3 in.)	1250 mm (49.2 in.)	1350 mm (53.1 in.)	1450 mm (57.1 in.)
L2850-L3250 25X8.50-14 Turf	1270 mm (50.0 in.)	1370 mm (53.9 in.)	1470 mm (57.9 in.)	1570 mm (61.8 in.)
L3250 6.00-16 Farm	1150 mm (45.3 in.)	1250 mm (49.2 in.)	1350 mm (53.1 in.)	1450 mm (57.1 in.)

IMPORTANT:

- The front tread width for the front loader application on 2WD models should not be greater than 1060mm (41.7 in.) for L2550, 1150mm (45.3 in.) for L2850, L3250.

◆ 4WD (Four Wheel Drive)

Front axle is not adjustable.

<p>F-3912</p>	Models	L2250		L2550	
	Tires	6-14 Farm	24 X 8.50-14 Turf	7-16 Farm	25 X 8.50-14 Turf
	Tread	1010 mm (39.8 in.)	1060 mm (41.7 in.)	1120 mm (44.1 in.)	1130 mm (44.5 in.)
	Models	L2850		L3250	
	Tires	7-16 Farm	212/80-D15, 27X8.50-15 Turf	8-16 Farm	212/80-D15, 27X8.50-15 Turf
	Tread	1120 mm (44.1 in.)	1175 mm (46.3 in.)	1170 mm (46.1 in.)	1175 mm (46.3 in.)

Rear Wheels

Rear tread can be adjusted in 6 steps depending on the model. (Shown below are the tread variation with the standard tires.)

To change the rear tread:

- (1) Jack up the rear tires.
- (2) Follow the illustrations below to get the desired tread width.



CAUTION

To avoid personal injury:

- When working on slopes or when working with trailer, set the wheel tread as wide as practical for the job for maximum stability.

IMPORTANT:

- Always attach tires as shown in the drawings below.
- If not attached as illustrated, transmission parts may be damaged.

Do not use tires larger than specified.

[L2250]

9.5-24 Farm		13.6-16 Truf	
	F-3913	F-3914	

[L2550 · L2850 · L3250]

Models							F-3915
L2550 11.2-24 Farm		1030 mm (40.6 in.)	1125 mm (44.3 in.)	1220 mm (48.0 in.)	1305 mm (51.4 in.)	1400 mm (55.1 in.)	
L2850 12.4-24 Farm	1050 mm (41.3 in.)	1150 mm (45.3 in.)	1240 mm (48.8 in.)	1335 mm (52.6 in.)	1420 mm (55.9 in.)	1515 mm (59.6 in.)	
L3250 13.6-26 Farm		1155 mm (45.5 in.)	1225 mm (48.2 in.)	1325 mm (52.2 in.)	1350 mm (53.1 in.)	1450 mm (57.1 in.)	

Models			F-3916
L2550 13.6-16 Turf		1145 mm (45.1 in.)	
L2850 · L3250 355/80-D20 Turf	1120 mm (44.1 in.)	1265 mm (49.8 in.)	

8.2 WHEEL HUB

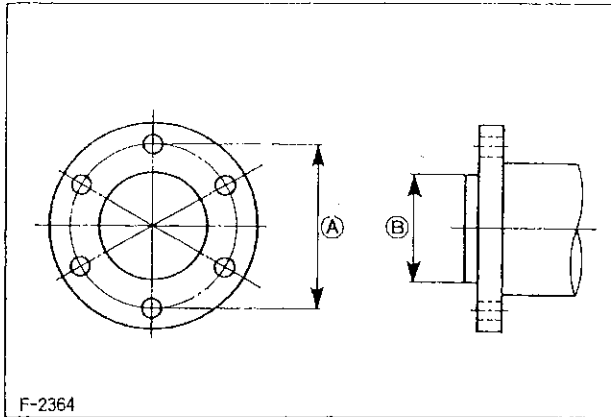

	Front wheel hub	Rear wheel hub
Bolt circle diameter (A)	152.4 mm (6 in.)	170 mm (6.7 in.)
Number of bolts	6	6
Bolt sizes	M14×1.5	M16×1.5
Hub pilot diameter (B)	117.4 mm (4.625 in.)	135 mm (5.315 in.)

8.3 TIRES

Though the tire pressure is factory-set to the prescribed level, it naturally drops slowly in the course of time. Thus, check it everyday and inflate as necessary.

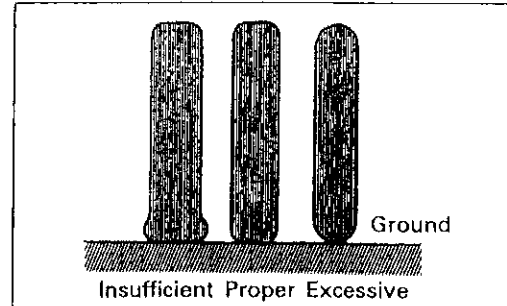

CAUTION

To avoid personal injury:

- Do not attempt to mount a tire. This should be done by a qualified person with the proper equipment.

■ Inflation Pressure

	Tire sizes	Inflation Pressure
Rear	9.5-24, 4PR	100 kPa (1.0 kgf/cm ² , 14 psi)
	11.2-24, 4PR	100 kPa (1.0 kgf/cm ² , 14 psi)
	12.4-24, 4PR	100 kPa (1.0 kgf/cm ² , 14 psi)
	13.6-16, 4PR	100 kPa (1.0 kgf/cm ² , 14 psi)
	13.6-24, 4PR	100 kPa (1.0 kgf/cm ² , 14 psi)
	13.6-26, 4PR	100 kPa (1.0 kgf/cm ² , 14 psi)
	355/80-D20, 4PR	100 kPa (1.0 kgf/cm ² , 14 psi)
Front	4.00-15, 4PR	220 kPa (2.2 kgf/cm ² , 32 psi)
	5.00-15, 4PR	220 kPa (2.2 kgf/cm ² , 32 psi)
	5.50-16, 4PR	220 kPa (2.2 kgf/cm ² , 32 psi)
	6.00-16, 6PR	325 kPa (3.25 kgf/cm ² , 46 psi)
	6-14, 4PR	200 kPa (2.0 kgf/cm ² , 28 psi)
	7-16, 4PR	180 kPa (1.8 kgf/cm ² , 26 psi)
	8-16, 4PR	160 kPa (1.6 kgf/cm ² , 23 psi)
	23×8.50-12, 4PR	160 kPa (1.6 kgf/cm ² , 23 psi)
	24×8.50-14, 4PR	160 kPa (1.6 kgf/cm ² , 23 psi)
	25×8.50-14, 4PR	160 kPa (1.6 kgf/cm ² , 23 psi)
	212/80-D15, 4PR	160 kPa (1.6 kgf/cm ² , 23 psi)
27×8.50-15, 4PR	160 kPa (1.6 kgf/cm ² , 23 psi)	

8.4 BALLAST

■ Selecting Front Ballast

Add weight to front end if needed for stability.

Heavy pulling and heavy rear mounted implements tend to lift front wheels. Add enough ballast to maintain steering control and prevent tip over.

Remove weight when it is no longer needed. Front weights are available from your Kubota Dealer.

Your dealer can help you decide how much is required for your particular application.



CAUTION:

To avoid personal injury:

- Additional ballast will be needed for transporting heavy integral implements. When the implement is raised, drive slowly over rough ground, regardless of how much ballast is used.

■ Select Rear Ballast Carefully.

Add weight to rear wheels if needed to improve traction or for stability. The amount of rear ballast should be matched to job and the ballast should be removed when it is not needed. Rear wheel weights are available or liquid may be added to the rear tires. Consult your Kubota dealer for the correct ballasting necessary for your particular application.

■ Using Liquid Weight in Rear Tires

Water and calcium chloride solution provides, safe economical ballast. Used properly, it will not damage tires, tubes or rims. The addition of calcium chloride is also recommended to prevent the water from freezing.

Use of this method of weighting the wheels has the full approval of the tire companies. See your tire dealer for this service. Do not fill any tire more than 75% full (to valve stem level).

Liquid weight per tire (75 Percent filled)

Tire sizes	9.5-24	11.2-24	12.4-24	13.6-24	13.6-26
Slush free at -10°C (14°F) Solid at -30°C (-22°F) (Approx. 1 kg (2 lbs.) CaCl ₂ per 4 ℓ (1 gal) of water)	75 kg (165 lbs.)	103 kg (227 lbs.)	117 kg (258 lbs.)	153 kg (337 lbs.)	172 kg (379 lbs.)
Slush free at -24°C (-11°F) Solid at -47°C (-52°F) (Approx. 1.5 kg (3.5 lbs.) CaCl ₂ per 4 ℓ (1 gal) of water)	81 kg (178 lbs.)	108 kg (237 lbs.)	125 kg (276 lbs.)	160 kg (352 lbs.)	181 kg (399 lbs.)
Slush free at -47°C (-52°F) Solid at -52°C (-62°F) (Approx. 2.25 kg (5 lbs.) CaCl ₂ per 4 ℓ (1 gal) of water)	85 kg (187 lbs.)	115 kg (253 lbs.)	133 kg (293 lbs.)	170 kg (375 lbs.)	192 kg (423 lbs.)

IMPORTANT:

- Do not fill front tires with liquid.

9. OPERATING INSTRUCTIONS

Pre-Start Checks

Prior to starting the engine, make pre-start checks according to the Maintenance Check List on page 39.



CAUTION

To avoid personal injury:

- Read "Safe Operation" in the front of this manual.
- Read the warning and caution labels located on the tractor.

9.1 OPERATING THE ENGINE



CAUTION

To avoid personal injury:

- To avoid the danger of exhaust fume poisoning, do not operate the engine in a closed building without proper ventilation.
- Make it a rule to set main gear shift lever, Hi-Lo gear shift lever, shuttle shift lever and PTO gear shift lever to the "neutral" positions before starting the engine.

■ Starting

- (1) Sit on the operator's seat. If the tractor is equipped with a ROPS, fasten the seat belt.
- (2) Push in the engine stop knob.
- (3) Place Main gear shift lever, Hi-Lo gear shift lever, shuttle shift lever and PTO gear shift lever in the "neutral" position.
- (4) Place hydraulic control levers in lowest positions.
- (5) Set the throttle lever approximately 1/4 of the way backward (approximately 1500 rpm position).
- (6) Insert the key into the key switch and turn it on.
- (7) Fully depress the clutch pedal. (The safety switch turns on.)
- (8) Check to see that all the lights on the Easy Checker are on.
- (9) Turn the key to start position and release when the engine starts.
- (10) Check to see that all the lights on the Easy Checker are off.

IMPORTANT:

- When starting the engine after long storage (of more than three months), first pull the engine stop knob and then activate the starter for about ten seconds to allow oil to reach every engine part.
- Do not turn the key switch to start position while the engine is running.
- When the temperature is below 0°C (32°F), place the main gear shift lever in the neutral position and keep the engine at medium speed to warm up the lubricant of engine and transmission at least 10 minutes. If the tractor is operated before the lubricant of engine and transmission is warm enough, the tractor life will be shortened.
- Do not operate the tractor under full load condition until it is sufficiently warmed up.
- Do not use starting fluid or ether.
- Do not leave your tractor in the rain. If it cannot be avoided, cover the muffler pipe to prevent rain drops from entering.
- When cold, blue or white exhaust fumes may come out occasionally (about a minute) from muffler, which is not abnormal. Colored fumes continued even longer can be extinguished by applying load to the engine. It should be avoided to continue engine slow idle for a long time or repeat engine starting more than necessary.

■ Starting Engine in the Low Temperature Range

If the ambient temperature is below -5°C (23°F) and the engine is very cold, start it in the following manner: Take steps (1) through (8) above; in step (5), pull the hand throttle backward all the way.

- (9) Turn the key to "Preheat" and keep it there for about 30 seconds.
- (10) Turn the key switch to the start position and the engine should start.
(If the engine fails to start after 10 seconds, turn off the key switch for 30 seconds. Then repeat steps (8) and (9). To protect the battery and the starter, make sure that the starter is not continuously turned for more than 30 seconds.)

■ Stopping the Engine

- (1) After slowing the engine, turn the key switch to "OFF" and pull the engine stop knob until the engine comes to complete stop.
- (2) Remove the key.

■ Warm-Up

For five minutes after engine start-up, allow engine to warm up without applying any load, this is to allow oil to reach every engine part. If load should be applied to the engine without this warm-up period, trouble such as seizure or breakage might develop.



CAUTION

To avoid personal injury:

- Be sure to apply the parking brake and set all levers in neutral during engine warm-up.

■ Warm-Up and Transmission Oil in the Low Temperature Range

A tractor with glide shift transmission utilizes a hydraulic clutch. Hydraulic oil serves as transmission oil, and power steering. In cold weather, the oil may be cold with increased viscosity. This can cause delayed oil circulation or abnormally low hydraulic pressure for some time after engine start-up. This in turn can result in trouble in the hydraulic system or a damaged power steering or a damaged hydraulic clutch. To prevent the above, observe the following instructions:

Warm up the engine according to the table below:

Ambient temperature	Warm-up time requirement
Above 0°C (32°F)	At least 10 minutes
0 to -10°C (32 to 14°F)	10 to 20 minutes
-10 to -20°C (14 to -4°F)	20 to 30 minutes
Below -20°C (-4°F)	More than 30 minutes

■ Block Heater (if equipped)

A block heater is available as an option from your dealer. It will assist you in starting your tractor when the ambient temperature is below 0°C (32°F).

9.2 OPERATING THE TRACTOR

■ Starting

- (1) If traveling on the road, check to see that the right and left brake pedals are properly connected.

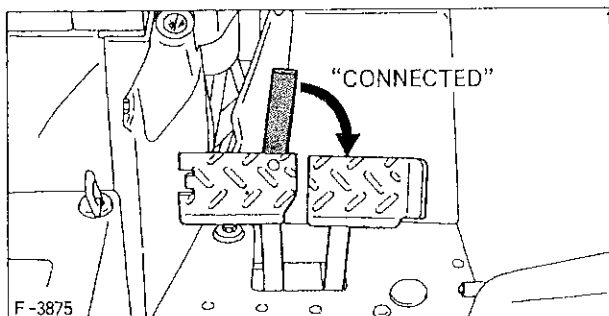

F-3875

- (2) Raise the implement.
- (3) Depress the clutch pedal, and shift the main, and Hi-Lo gear shift levers to the desired speed and shift the shuttle lever to the desired direction of travel.
- (4) Accelerate the engine to a proper level to prevent engine stall.
- (5) Unlock the parking brake and slowly release the clutch.

IMPORTANT:

- Be sure to release the parking brake before moving the tractor.
- Change traveling speed only after depressing the clutch pedal all the way. (Except GST type)
- Avoid slipping the clutch to prolong the clutch service life, paying attention to the following points:
 - Do not slip the clutch when changing speed.
 - Select proper gear and engine speeds depending on the type of job.
 - Do not operate the tractor with your foot resting on the clutch pedal.
- For road travel, start the tractor in a lower gear, and then change to a higher gear. It will prolong the clutch service life. (GST type)



CAUTION

To avoid personal injury:

- Sudden release of the clutch may cause the tractor to lunge in an unexpected manner.
- To help assure straight line stops when driving at transport speeds, lock the brake pedals together. Uneven braking at road speeds could cause the tractor to roll-over.
- Do not allow any person other than the driver to ride on the tractor.
- Do not drive the tractor close to the edges of ditches or banks which may collapse under the weight of the tractor. Especially when the ground is loose or wet.
- Always back up when going up a steep slope. Driving forward could cause the tractor to tip over backward. Stay off hills and slopes too steep for safe operation.
- If descending a slope, never disengage the clutch or shift levers to neutral. Doing so could cause the tractor to speed up out of control.
- Roll-Over Protective Structure (ROPS) with a seat belt is recommended by Kubota in almost all applications. Refer to the Safety Section.
- Do not apply the differential lock while traveling at road speeds. Doing so could cause the tractor to swerve out of control.

- When traveling on road with 3-point hitch mounted implement attached, be sure to have sufficient front weight on the tractor to increase steering stability.
- When traveling on a road, attach the SMV emblem to the tractor to identify it as a low speed vehicle.
Observe all traffic regulations.

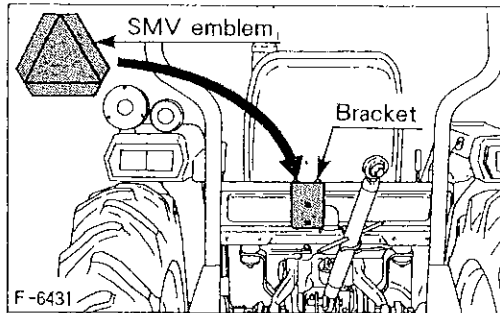

■ Stopping

- (1) Slow the engine down.
- (2) Step on the clutch and brake pedal.
- (3) After the tractor has stopped, disengage the PTO, lower the implement, shift the transmission to neutral, release the clutch pedal, pull the parking rod to apply the parking brake.

■ Parking

- (1) When parking, be sure to set the parking brake.
- (2) Before getting off the tractor, disengage the PTO, lower all implements, place all control levers in their neutral positions, set the parking brake, stop the engine and remove the key.

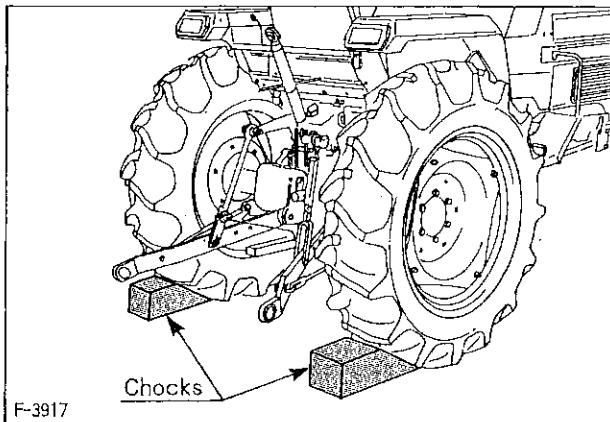

- (3) If it is necessary to park on an incline, be sure to chock the wheels to prevent accidental rolling of the machine.



CAUTION

To avoid personal injury:

- Always set the parking brake and stop the engine before leaving the tractor seat.

■ Directions for Use of Power Steering

- (1) Power steering is activated only while the engine is running. Slow engine speeds make the steering wheel a little heavy to handle. While the engine is stopped, the tractor functions in the same manner as ones without power steering.
- (2) When the steering wheel is turned all the way to the stop, the relief valve is activated. Do not hold the steering wheel in this position for a long period of time.
- (3) Avoid turning the steering wheel while the tractor is stopped, and/or with slow engine speeds, or tires and rims may wear out sooner.
- (4) The power steering mechanism makes the steering wheel very easy to handle. Be careful when driving on a road at high speeds.

■ Differential Lock

Though very useful when used properly, the differential lock is very dangerous if misused, and may cause breakdown. Use the differential lock in the following cases:

- (1) If one wheel is caught in mud and the tractor cannot go forward.
- (2) If the wheels slip during plowing operation.



CAUTION

To avoid personal injury:

- When using the differential lock, always slow the engine down.
- The differential lock automatically releases when the pedal is released. If this does not happen, lightly step on the brake pedals alternately, or turn the steering wheel slightly.
- Always disengage the differential lock before turning the tractor. It is very dangerous not to do so.
- Do not engage differential lock while one wheel is spinning and the other is completely stopped. It may cause the tractor to lunge unexpectedly.

9.3 PULLING



CAUTION

To avoid personal injury:

- Never pull from the top link, the rear axle or any point above the drawbar. Doing so could cause the tractor to tip over rearward causing personal injury.

For pulling, attach to the drawbar. Use the 3-point hitch only with equipment designed for 3-point hitch usage.

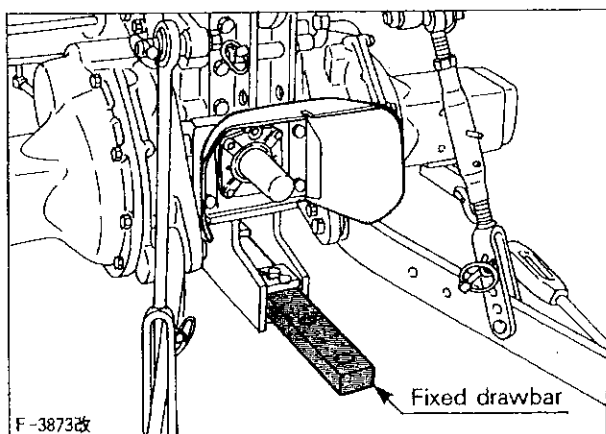

F-3873改

9.4 CHECK DURING DRIVING

While driving, make the following checks to see that all the parts are functioning normally.

■ Fuel

Be careful not to empty the fuel tank. Otherwise air may enter the fuel system. Should this happen, the system should be bled (see page 40 Fuel system maintenance).

■ Engine Oil Pressure Warning Light

The oil pressure warning light goes on if the oil pressure in the engine goes below the prescribed level. If this should happen during operation, and it does not go off even if the engine is accelerated to more than 1000 rpm (16.7 r/s), immediately stop the engine, and check:

- (1) The quantity of engine oil (see page 38, 42 Engine oil).
- (2) The lubrication system (see page 43 Engine oil filter).

■ Battery Charge Warning Light

The charge warning light goes on if the alternator is not charging the battery.

Should this happen, immediately stop the engine and check:

- (1) Wiring failure.
- (2) Connection failure of alternator and regulator.
- (3) Alternator belt tension.

HOW TO CHECK THE EASY CHECKER

(If equipped)

■ Battery

If the battery electrolyte drops close to the "LOW LEVEL" mark; the warning light in the Easy Checker comes on. Add distilled water.

■ Coolant

If the coolant in the coolant recovery reservoir drops to the "LOW LEVEL" mark, the warning light in the Easy Checker comes on. Add the proper mixture of water and anti-freeze up to the full level in the coolant recovery reservoir.



CAUTION

To avoid personal injury:

- Do not remove radiator filler cap until coolant temperature is well below its boiling point. Then loosen cap slightly to the stop to relieve any pressure before removing cap completely.

If engine temperature gauge needle moves past the red zone on the gauge, stop the engine and check for the following:

- (1) Shortage or leakage of the coolant.
- (2) Foreign matter on the radiator net and dust and dirt between the radiator fins and tube.
- (3) Loose fan drive belt.
- (4) Internal blockage in the radiator core or hose.

■ Air Cleaner

If the air cleaner is clogged, the corresponding warning light in the Easy Checker comes on. Clean the air cleaner element according to the instructions on page 48.

Immediately Stop the Engine if:

- (1) The engine suddenly slows down or accelerates,
- (2) Unusual noises suddenly develop,
- (3) Exhaust suddenly becomes very dark,
- (4) The oil pressure warning light goes on during operation.

Note:

- For checking and servicing of your tractor, contact your nearest Kubota dealer for instructions.

10. MAINTENANCE

10.1 DAILY CHECK

To prevent trouble from occurring, it is important to know the condition of the tractor. Check it before starting.



CAUTION

To avoid personal injury:

- Be sure to check and service the tractor on a flat place with the engine shut off and the parking brake on.

	No.	Check item	Reference page		No.	Check item	Reference page	
Walking around the tractor	1	The tire, pressure, wear and damage	31	Turning the key switch on	1	Performance of the easy checker light	15	
	2	Oil and water leaks	—		Starting the engine	2	Headlights Tail lights Hazard lights	—
	3	Engine oil level	42			3	Performance of the meters and gauges	—
	4	Transmission fluid level	43			4	Horn(if equipped)	—
	5	Coolant level in the recovery tank	46	Others	1	Color of the exhaust fumes	—	
	6	Dust in the air cleaner baffle	48		2	Going off of the lights on the Easy Checker	15	
	7	Radiator screen	—		3	Check the brake for proper operation.	—	
	8	Damage of tractor body, tightness of all bolts and nuts	—		1	Check the areas where previous trouble was experienced.	—	
	9	Damage of the SMV emblem Clean or replace as necessary if equipped	2					
While sitting on the operator's seat	1	Throttle pedal Brake pedals Clutch pedal	—					
	2	Parking brake	—					
	3	Steering wheel	—					

10.2 LUBRICANTS

To prevent serious damage to hydraulic systems, use only specified fluid or its equivalent.

No.	Locations	Capacities						Lubricants							
		L2250	L2550	L2550GST	L2850	L2850GST	L3250								
1	Fuel	29 ℓ (7.7 U.S. gals.)						No.2 – D diesel fuel No.1 – D diesel fuel below –10°C (14°F)							
2	Coolant	4.6 ℓ (4.9 U.S. qts.)			5.6 ℓ (5.9 U.S. qts.)			Fresh clean water with anti-freeze							
3	Engine crankcase	5.7 ℓ (6.0 U.S. qts.)			8.5 ℓ (8.9 U.S. qts.)			<ul style="list-style-type: none"> Engine oil; API Service CC or CD <table border="1"> <tr> <td>Below 0°C (32°F)</td> <td>SAE 10W or 10W-30</td> </tr> <tr> <td>0~25°C (32~77°F)</td> <td>SAE 20 or 10W-30</td> </tr> <tr> <td>Above 25°C (77°F)</td> <td>SAE 30 or 10W-30</td> </tr> </table>		Below 0°C (32°F)	SAE 10W or 10W-30	0~25°C (32~77°F)	SAE 20 or 10W-30	Above 25°C (77°F)	SAE 30 or 10W-30
Below 0°C (32°F)	SAE 10W or 10W-30														
0~25°C (32~77°F)	SAE 20 or 10W-30														
Above 25°C (77°F)	SAE 30 or 10W-30														
4	Transmission case	28.5 ℓ (7.5 U.S. gals.)	27 ℓ (7.1 U.S. gals.)	28.5 ℓ (7.5 U.S. gals.)	27 ℓ (7.1 U.S. gals.)	28.5 ℓ (7.5 U.S. gals.)	<ul style="list-style-type: none"> Multi-grade transmission fluid The transmission fluids listed on page 57 or equivalent are recommended.								
5	Steering gear case	0.1 ℓ (0.11 U.S. qt.)						Gear oil SAE 80 or SAE 90 (See page 57)							
6	Steering gear box (manual)	0.2 ℓ (0.21 U.S. qt.)	—	0.2 ℓ (0.21 U.S. qt.)	—	0.2 ℓ (0.21 U.S. qt.)									
7	Front axle case [4WD only]	6 ℓ (6.3 U.S. qts.)	6.5 ℓ (6.8 U.S. qts.)												
8	Greasing	No. of greasing points						Capacity	Type of grease						
	Front wheel hub	2 [2WD only]						A small amount	Bearing grease (See page 57)						
	Knuckle shaft	2 [2WD only]						Until grease overflows	Multipurpose type grease (See page 57)						
	Clutch pedal	1													
	Brake pedal	1													
	Pedal shaft support	1													
	Top link	2			1										
	Top link bracket	2 [with Draft Control]													
	Lift rod	1													
	Battery terminal	2						A small amount							
Shift guide	—	1	—	1	—	A small amount									

11. CHECK AND MAINTENANCE

11.1 FUEL

■ Checking and Refueling



CAUTION

To avoid personal injury:

- Stop the engine before adding fuel. Keep fuel away from sparks and flames.

- (1) Use No.2-Diesel fuel.
- (2) Use No.1-Diesel fuel, if temperature is below -10°C (14°F).

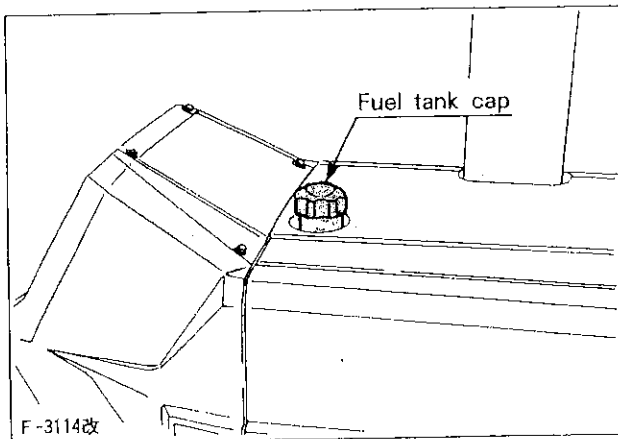

Fuel tank capacity	29 l (7.7 U.S.gals.)
--------------------	----------------------

IMPORTANT:

- Always use a strainer in refueling to prevent fuel injection pump contamination.

■ Fuel Line Bleeding

Air must be removed:

- (1) When the fuel filter or lines are removed.
- (2) When tank becomes completely empty.
- (3) After the tractor has not been used for a long period of time.

Bleeding procedure is as follows:



CAUTION

To avoid personal injury:

- Do not bleed the fuel system when the engine is hot.

- (1) Fill the fuel tank with fuel, and open the fuel cock.

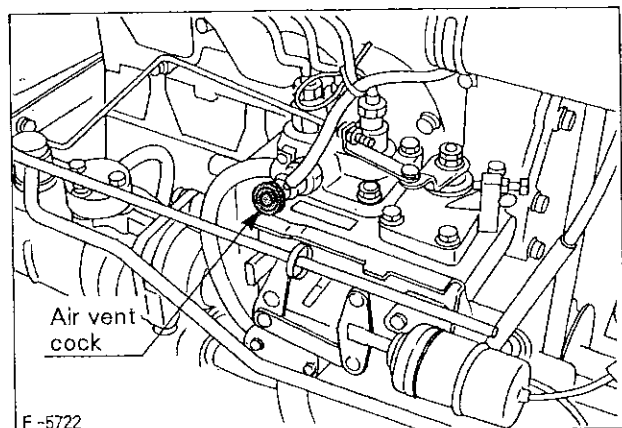
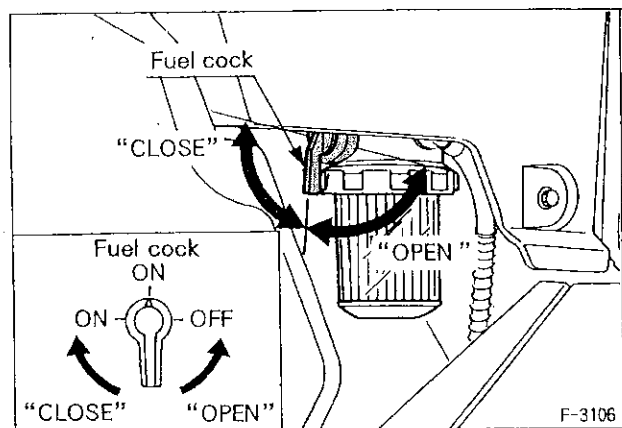

- (2) Open the air vent cock on the fuel injection pump.
- (3) Start the engine for about 1 minute, and then stop the engine.
- (4) Close the air vent cock.

IMPORTANT:

- Always close the air vent cock except for bleeding fuel lines. Otherwise, engine runs irregularly or stalls frequently.

■ Fuel Filter Bowl Cleaning

When period of operation reaches approx. 100 hours, clean the fuel filter. This job should not be done in the field, but in a clean place.

- (1) Close the fuel filter cock.
- (2) Unscrew the screw ring and remove the filter bowl, and rinse the inside with kerosene.
- (3) Take out the element and dip it in the kerosene to rinse.
- (4) After cleaning, reassemble the fuel filter, keeping out dust and dirt.
- (5) Bleed the fuel system.

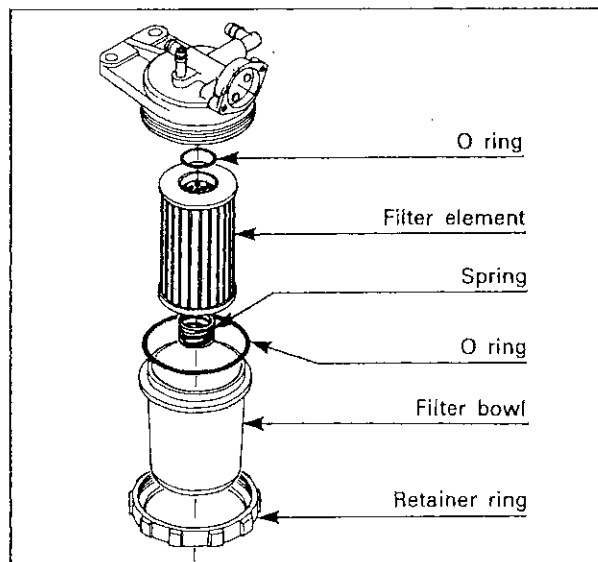
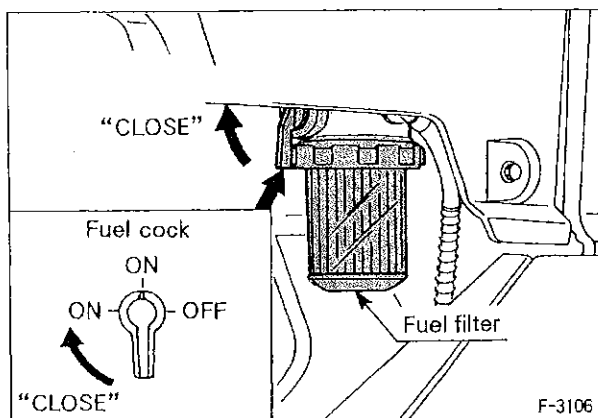

IMPORTANT:

- If dust and dirt enter the fuel, the fuel pump and injection nozzles are subject to quick wear. To prevent this, be sure to clean the fuel filter bowl periodically.

■ Fuel Line Check



CAUTION

To avoid personal injury:

- Stop the engine when attempting to check the fuel line.
- Check the fuel line periodically. The fuel line is subject to wear and aging, fuel may leak onto the running engine, causing a fire.

The fuel line connections should be checked every 6 months or 200 service hours, whichever occurs first.

- (1) If the clamp is loose, apply a slight coat of lubricant onto the threads and securely retighten it.

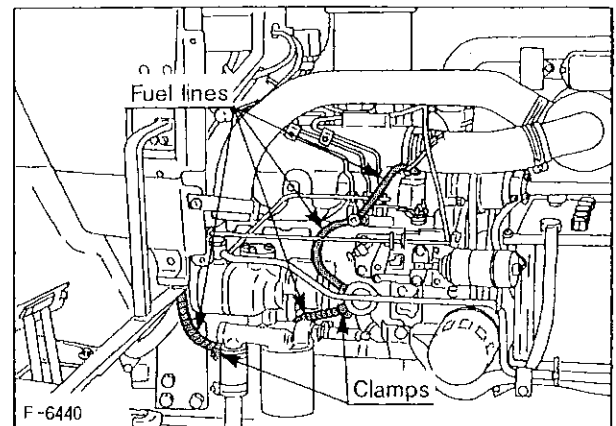

- (2) The fuel line is made of rubber and may deteriorate by age.
- (3) After inspection, if the fuel line and clamps are found damaged or deteriorated, replace them.
- (4) After the fuel line and clamps have been changed, bleed the fuel system.

IMPORTANT:

- When the fuel line is disconnected for change, close both ends of the fuel line with a piece of clean cloth or paper to prevent dust and dirt from entering. Dust and dirt may cause a malfunction of the fuel injection pump. In addition, particular care must be taken not to admit dust and dirt into the fuel pump.

11.2 ENGINE OIL

Oil Level Check and Replenishment

- (1) Check engine oil before starting the engine or 5 minutes or more after the engine has stopped.
- (2) To check the oil level, draw out the oil gauge, wipe it clean, replace it, and draw it out again. Check to see that the oil level lies between the two notches.
- (3) If the level is too low, add new oil to the prescribed level.

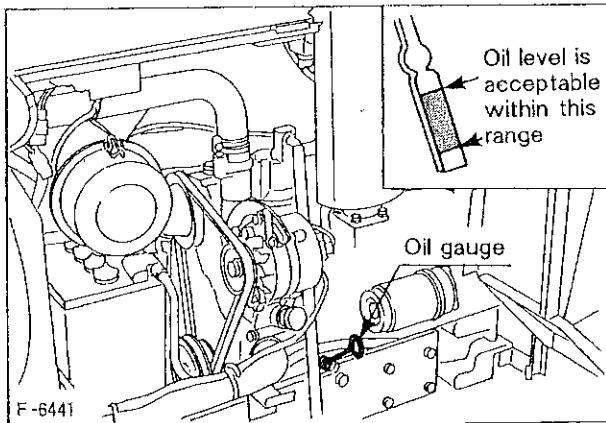

- (4) When using an oil of different manufacturer or viscosity from the previous one, remove all of the old oil.
Never mix two different types of oil.
- (5) Use the proper SAE Engine Oil according to the air temperatures.

ENGINE OIL VISCOSITY CHART

Below 0°C (32°F)	SAE 10W or 10W-30
0~25°C (32~77°F)	SAE 20 or 10W-30
Above 25°C (77°F)	SAE 30 or 10W-30

Engine Oil Change



CAUTION

To avoid personal injury:

- Before changing the oil, be sure to stop the engine.

- (1) To drain the used oil, remove the drain plug at the bottom of the engine and drain the oil completely. All the used oil can be drained out easily when the engine is still warm.
- (2) Reinstall the drain plug.
- (3) Fill with the new oil up to the upper notch on the oil gauge.

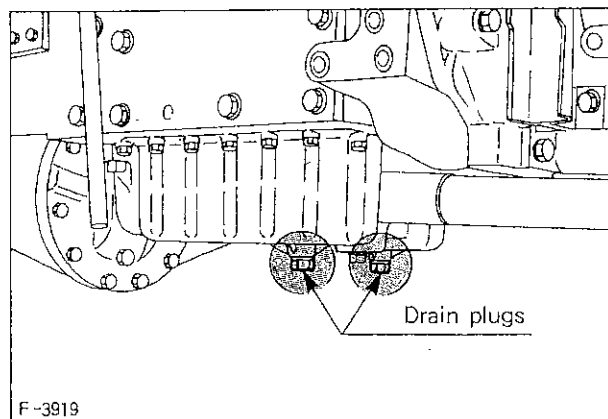
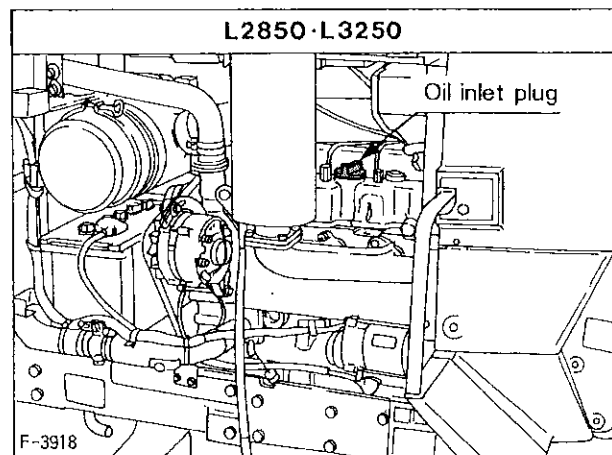
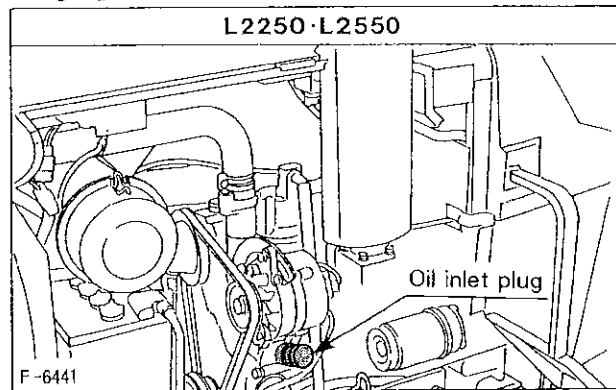

■ Engine Oil Filter Cartridge Change



CAUTION

To avoid personal injury:

- Be sure to stop the engine before changing the oil filter cartridge.

- (1) The oil filter cartridge must be changed every 400 service hours.
- (2) Apply a slight coat of oil onto the cartridge gasket.
- (3) To install the new cartridge, screw it on by hand. Overtightening may cause deformation of the rubber gasket.
- (4) After the new cartridge has been replaced, the engine oil level will normally lower a little. Add engine oil to proper level. Check for oil leaks around filter gasket.

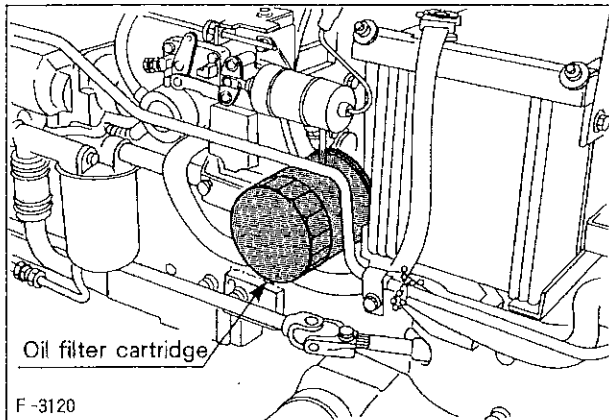

IMPORTANT:

- To prevent serious damage to the engine, replacement element must be highly efficient. Use only a genuine KUBOTA filter or its equivalent.

11.3 TRANSMISSION FLUID



CAUTION

To avoid personal injury:

- Be sure to stop the engine before checking and changing the transmission fluid.

■ Fluid Level Check and Replenishment

View the fluid level through the fluid level gauge. If low, replenish through the port.

Use multi-grade transmission fluid. (See page 57)

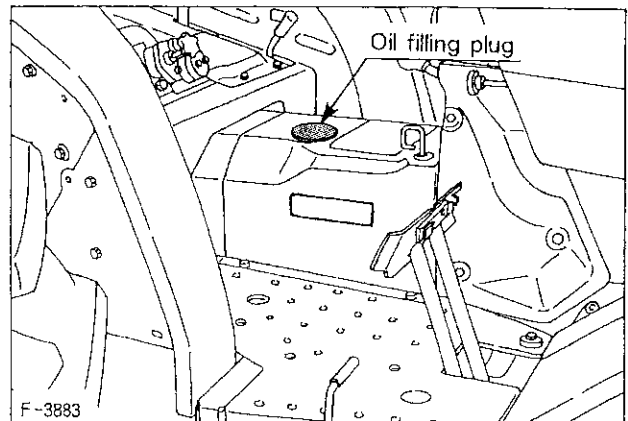
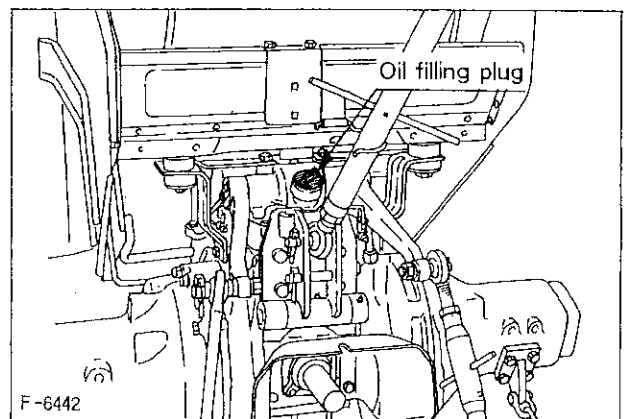
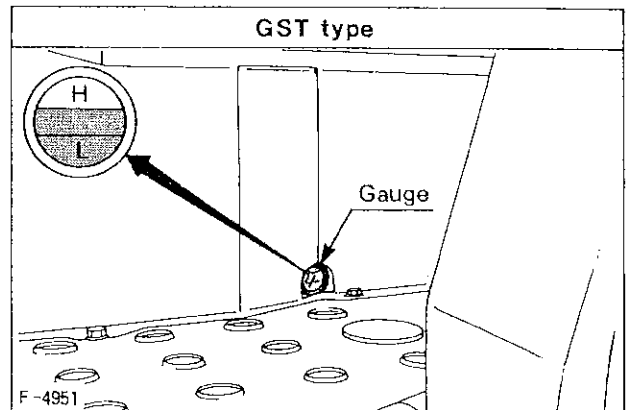
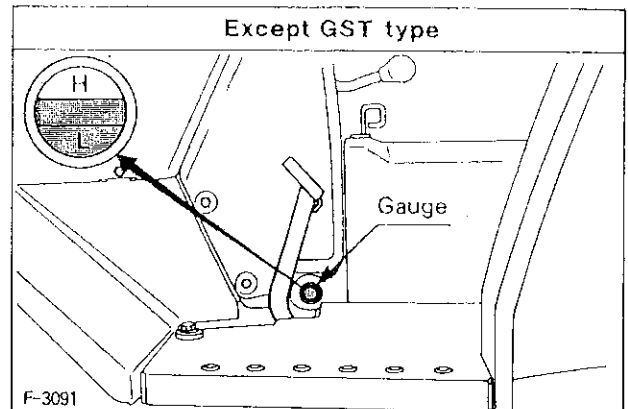

■ Transmission Fluid Change

The fluid in the transmission case is also used for the hydraulic system and power steering system.

- (1) To drain the transmission case, place an oil pan underneath the transmission case and remove the drain plugs at the bottom of the transmission case and the brake case.
- (2) After draining install drain plugs and fill with new transmission fluid.
- (3) After running the engine for a few minutes, stop it and check the oil level again; add oil to prescribed level.

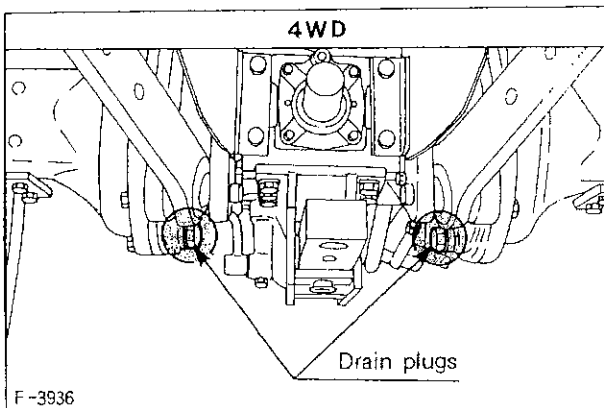
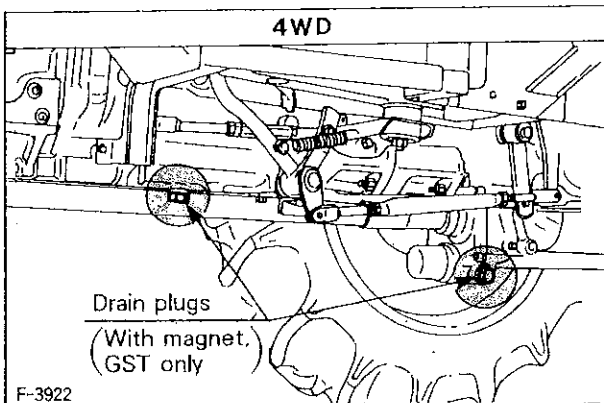
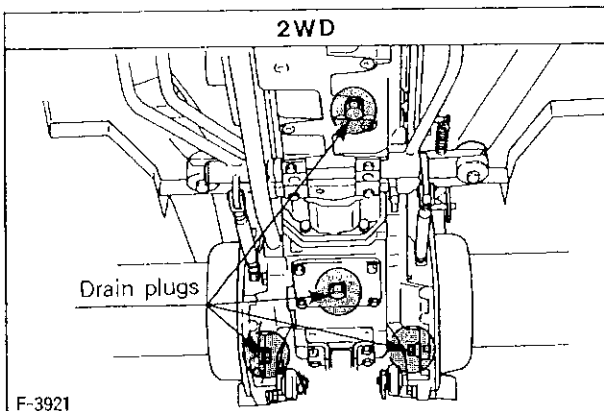

■ Cleaning Magnetic Plug [GST type]

Remove the magnetic plug and clean off metal filings.

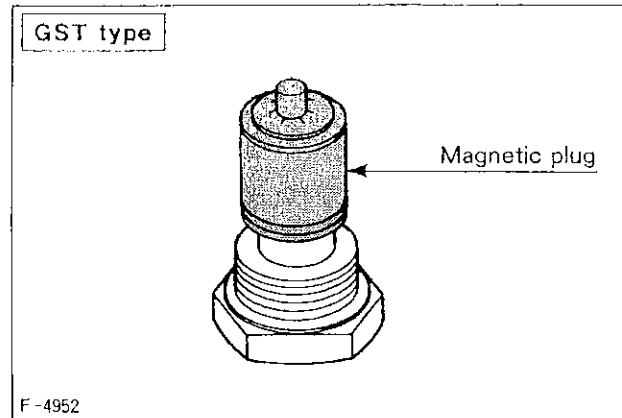

IMPORTANT:

- Do not operate the tractor immediately after changing the transmission fluid.
Run the engine at medium speed for a few minutes to prevent damage to the transmission.

■ Hydraulic Oil Filter and Paper Filter (Cartridge) Replacement

- (1) Detach the oil filter cartridge.
- (2) Apply a slight coat of oil onto the cartridge gasket.
- (3) Fill the new cartridge with hydraulic oil.
- (4) To install the new cartridge, screw it in by hand. Over tightening may cause deformation of rubber gasket.
- (5) After the new cartridge has been replaced, the transmission fluid level will decrease a little. Make sure that the transmission fluid does not leak through the seal, and check the fluid level.

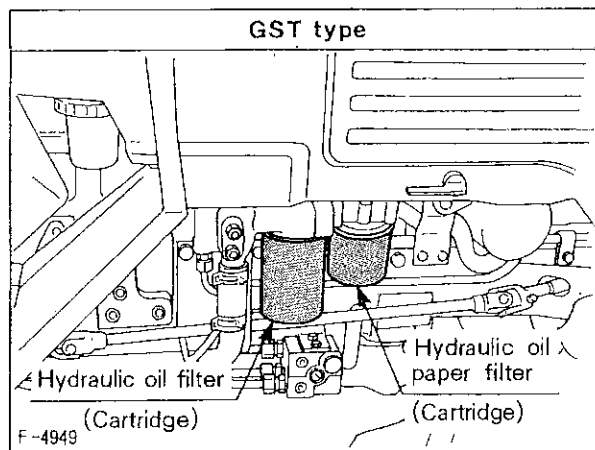
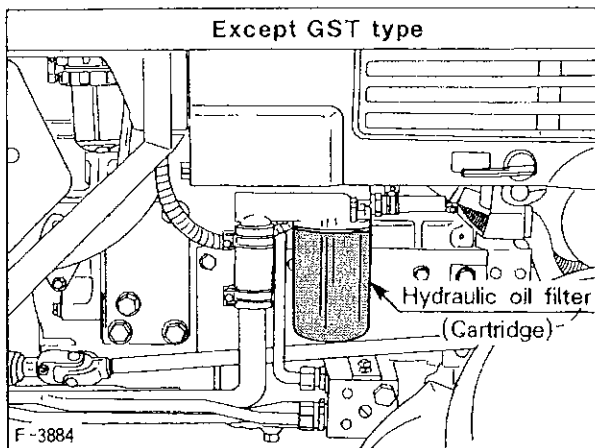

IMPORTANT:

- To prevent serious damage to hydraulic system, replacement of filter and paper filter must be a highly efficient. Filter is 100 μm and paper filter is 10 μm . Use only a KUBOTA genuine filter or its equivalent.

11.4 FRONT AXLE CASE OIL [4WD]

■ Oil Change

Remove the drain and filling port plug. After draining, replace the drain plug and fill with new oil.

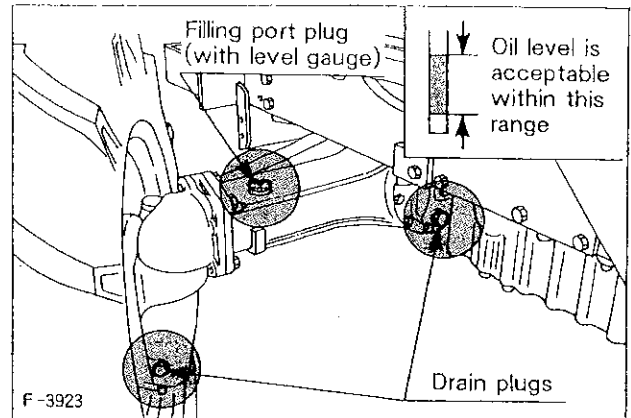

11.5 STEERING GEAR BOX OIL

[Manual Steering Only]

If the oil level is low, fill with gear lube up to the oil inlet port. (after remove the battery.)

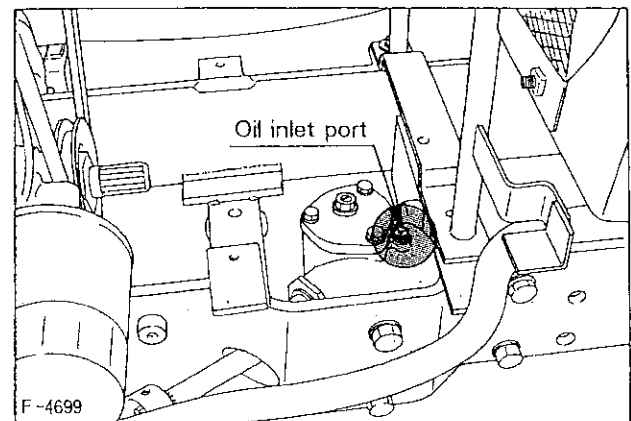

11.6 STEERING GEAR CASE OIL

■ Check and Replenishment

- (1) To check the oil level, remove the filling plug. Check that the oil level reaches the rim of the filling port.
- (2) If the oil level is low, fill with new oil.

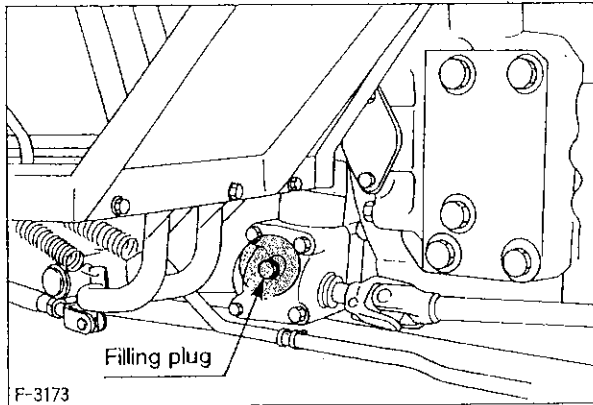

11.7 RADIATOR



CAUTION

To avoid personal injury:

- Do not remove the radiator cap until coolant temperature is well below its boiling point. Then loosen cap slightly to the first stop to relieve any excess pressure before removing cap completely.

■ Coolant Check, Replenishment and Change

Check the coolant level at the coolant recovery reservoir. If it is low, add the proper mixture of water and anti-freeze up to the full level.

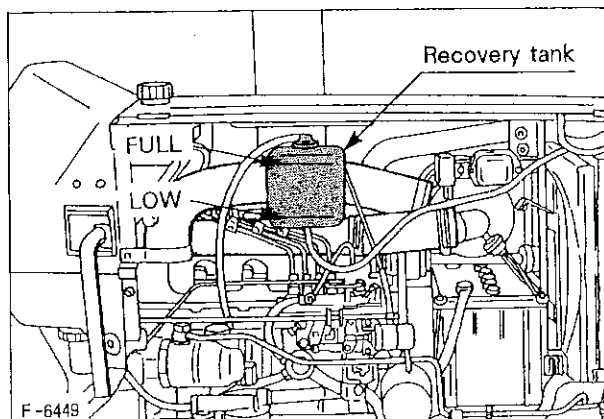

IMPORTANT:

- Use clean, fresh water and anti-freeze to fill the coolant recovery reservoir.
- If the radiator cap has to be removed, follow the caution above and securely retighten the cap.

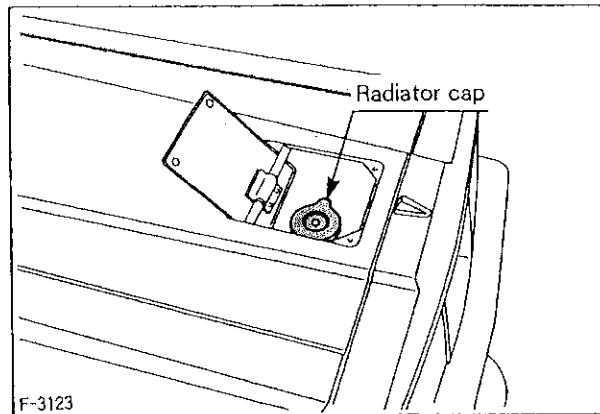

- To drain the used coolant, open the radiator drain plug and remove radiator cap. The radiator cap must be removed to completely drain the radiator.

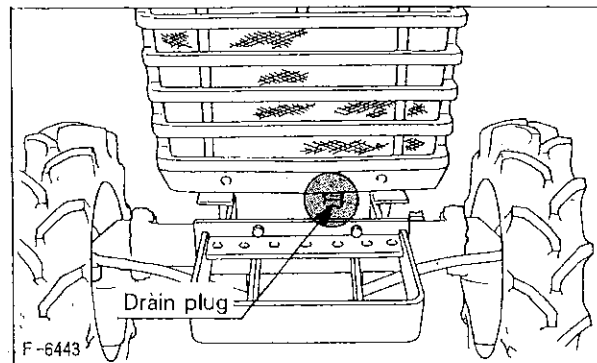

- Be sure to close the pressure cap securely. If the cap is loose or improperly closed, water may leak out and the engine could overheat.
- Do not use an anti-freeze and a scale inhibitor at the same time.

■ Checking Radiator Hoses (water pipes)

Check to see if radiator hoses are properly fixed every 200 hours of operation or six months, whichever comes first.

- (1) If clamp bands are loose or water leaks, tighten bands securely.
- (2) Replace hoses and tighten clamp bands securely, if radiator hoses are swollen, hardened or cracked.

Replace hoses and clamp bands every 2 years or earlier if checked and found that hoses are swollen, hardened or cracked.

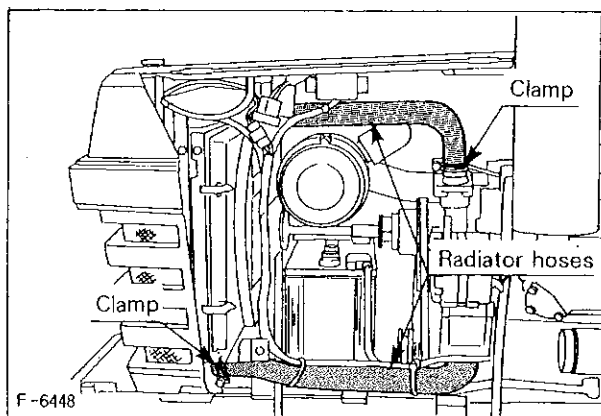

■ Precaution at Overheating

Take the following actions in the event the coolant temperature be nearly or more than the boiling point, what is called "Overheating".

- (1) Stop the machine operation in a safe place and keep the engine unloaded idling.
- (2) Don't stop the engine suddenly, but stop it after about 5 minutes of unloaded idling.
- (3) Keep yourself well away from the machine for further 10 minutes or while the steam blown out.
- (4) Checking that there gets no danger such as burn, get rid of the causes of overheating according to the manual, see "Engine troubleshooting" section. And then, start again the engine.

■ Water Leakage Remedy

- (1) A small water leak can be eliminated with the Kubota Radiator Cement No.40 or equivalent.
- (2) If water leakage should become excessive, consult your local dealer.

■ Cooling System Cleaning (Radiator)

- (1) The cooling system should be cleaned on the following occasions:
 - Every 800 service hours
 - When adding an anti-freeze solution.
 - When changing from water containing anti-freeze to pure water.
- (2) When cleaning the cooling system, Kubota Scale Inhibitor No.20, or its equivalent, is recommended to effectively wash away scale build-up.

■ Anti-Freeze

If the cooling water freezes, the engine cylinder and radiator may crack. In cold weather before the temperature drops below 0°C (32°F), add a proper amount of anti-freeze to the tractor coolant system.

- (1) There are two types of anti-freeze solutions, permanent type (PT) and semi-permanent type (SPT). For the Kubota Engine, be sure to use the permanent type.
- (2) When anti-freeze is used for the first time, drain and flush the cooling system completely.
- (3) The radiator should be filled with 50 percent each of anti-freeze solution and water as recommended by the anti-freeze manufacturer. Most anti-freeze contains a corrosion inhibitor and will allow a higher operating temperature in the radiator during the hot season.
- (4) Mix the anti-freeze and the water first, then pour the mixture into the radiator.
- (5) When the coolant mixed with anti-freeze decreases due to evaporation, replenish with water only. If loss has been due to leaking, add water and anti-freeze mixture with the same mix ratio as the original preparation.
- (6) Anti-freeze solutions absorb moisture, so be sure to securely close the container after use.
- (7) Anti-freeze and water should be changed every year.
- (8) Do not use an anti-freeze and a scale inhibitor at the same time. This may cause sludge to form, adversely affecting the engine.

■ Radiator Net and Radiator Core

Check daily to be sure the radiator net and radiator core are clean.

Dirt or chaff in the radiator net and radiator core decrease cooling performance.

To clean, detach the net and remove all the foreign material.

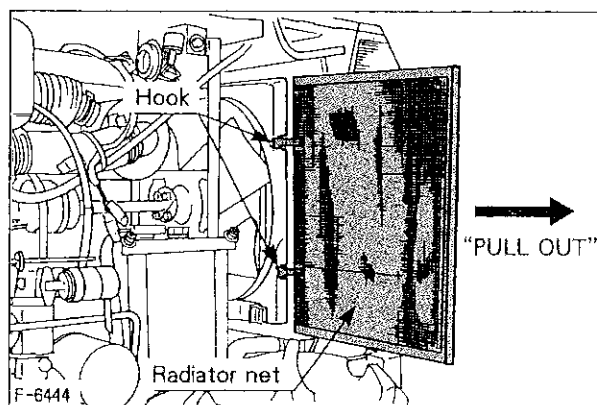

11.8 AIR CLEANER

- (1) The air cleaner uses one dry element, never apply oil.
- (2) Do not let dust build up to more than the half level in the cover. Detach the baffle from the cover and clean out the dust—normally once a week, everyday in working conditions that are especially dusty.
- (3) Do not touch element except in cases where cleaning is required
- (4) When cleaning the element, refer to the instructions below.
- (5) If the element is stained with carbon or oil, replace it.
- (6) Change the element once yearly or after every sixth cleaning, whichever comes first.

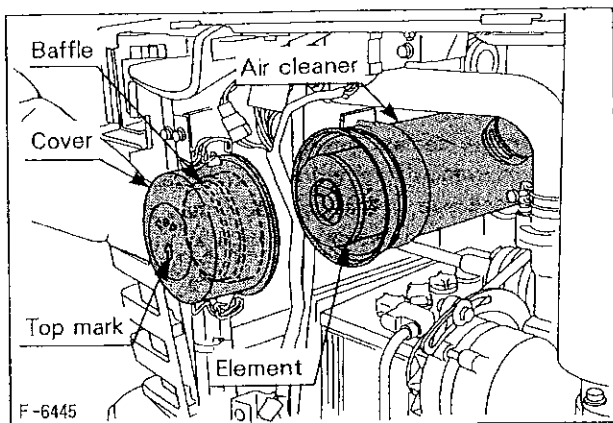

IMPORTANT:

- Be sure to refit the cover with the arrow ↑ (on the rear) upright. If the cover is improperly fitted, dust passes by the baffle and directly adheres to the element.
- Do not run the engine with filter element removed.

■ Air Filter Element Cleaning

- (1) To clean the element, use clean dry compressed air on the inside of the element.
Air pressure at the nozzle must not exceed 0.69MPa (7kgf/cm² ; 100 psi).
Maintain reasonable distance between the nozzle and the filter.
- (2) To wash the element, use Donaldson ND-1500 Filter Cleaner, or its equivalent, which is especially effective on oily and soot-laden filters.
Follow instructions that are supplied with the filter cleaner.

11.9 BATTERY



CAUTION

To avoid personal injury:

- Never remove the battery cap while the engine is running.
- Keep electrolyte away from eyes, hands and clothes. If you are splattered with it, wash it away completely with water immediately.

Mishandling the battery shortens the service life and adds to maintenance costs. Be sure to service it correctly so that it will develop its full potential performance.

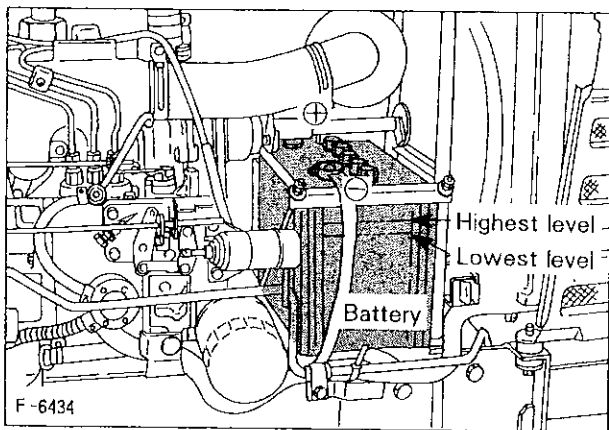

CAUTION

To avoid personal injury:

- Keep open sparks and flames away from the battery at all times, especially when charging the battery. Hydrogen gas mixed with oxygen becomes very explosive.

- (1) If the battery is weak, the engine is difficult to start and the lights become dim. It is important to check the battery daily and recharge before trouble occurs.
- (2) The water in the electrolyte evaporates during recharging. Liquid shortage damages the battery. Excessive liquid spills over and damages the tractor body. If low, fill the battery with distilled water.
- (3) To slow charge the battery, connect the battery positive terminal to the charger positive terminal and the negative to the negative, then recharge in the standard fashion.
- (4) A boost charge is only for emergencies. It partially charges the battery at a high rate and in a short time. When using a boost-charged battery, it is necessary to recharge the battery as early as possible. Failure to do this extremely affects the service life.



CAUTION

To avoid personal injury:

- To avoid accidental short circuit, be sure to attach the positive cable to the positive terminal before the ground cable is attached to the negative terminal.

IMPORTANT:

- If the tractor is to be operated for a short time without a battery (using a slave battery for starting), do not, under any circumstances, interrupt the circuit by switching off the key switch before stopping the engine by means of fuel pump shut-off knob. Use additional current (lights) while engine is running. Insulate terminal of battery cable before starting by means of slave battery. If this advice is disregarded, damage to alternator and regulator may result.

■ Dry Type Battery Charging

- (1) Remove vent plugs and discard temporary sealing tapes.
- (2) Fill each cell with electrolyte having a specific gravity given in Table 1 up to the middle levels marked on the battery case side.

Table 1

	AIR TEMPERATURES	
	TEMPERATE Ordinarily below 20°C (68°F)	TROPICAL Frequently above 20°C (68°F)
sp.gr.of Electrolyte for Filling	1.260	1.240
sp.gr.of Electrolyte when fully charged	1.260 to 1.275	1.240 to 1.255

- (3) After standing 2 to 3 hours, correct the electrolyte to proper level.
- (4) Connect positive terminal ⊕ of battery, with positive terminal of D.C. charging unit, and negative terminal ⊖ with negative terminal.
- (5) Batteries are preferably charged by the current shown in Table 2. Keep vent plugs removed during charging.

Table 2

TYPE	Volts (V)	Number of plate per cell	Capacity at		Volume of Electrolyte (ℓ)	Normal Charging Rate (A)
			20 H.R (A.H)	5 H.R (A.H)		
75D26R	12	13	65	52	4.2	6.5
75D31R	12	15	70	60	4.7	7

- (6) Check temperature of electrolyte, if it reaches 40°C (104°F), lower the charging rate. When the temperature is too high, reduce charging rate and charge for a proportionately longer period.
- (7) If the tractor is stored after original charge, periodically recharge as shown below:

Tabel 3

Period of storage from manufactured (months)	Recharge (hours)
0-6	about 3~5 hours
6-12	10
over 12	30

A battery is fully charged when the cells are all gassing freely and the specific gravity ceases to rise for three consecutive readings taken at hour intervals. Specific gravity should be adjusted to that shown in Table 1.

- (8) Check electrolyte level two hours after charging has finished and correct if necessary by adding distilled water.

Note:

- The tractor has been shipped with a dry battery. Your dealer will fill it with electrolyte and charge it for initial use.

Directions for Storage

- (1) When storing the tractor for long periods of time, remove the battery from the tractor, adjust the electrolyte to the proper level and store in a dry place out of direct sunlight.
- (2) The battery self-discharges while it is stored. Recharge it once a month in hot seasons and once every two months in cold seasons.

11.10 FUSE AND LIGHT

Fuses

The tractor electrical system is protected from potential damage by fuses. There are a total of six fuses in the tractor electrical system. Five of the fuses are located in a fuse box on the bonnet support. The sixth fuse is an in-line fuse. Refer to the illustrations and chart below for the location of the fuses and fuse amperage. Inoperative electrical components may indicate that a fuse has been blown. A blown fuse indicates that there is an overload or short somewhere in the electrical system.

IMPORTANT:

- Before replacing a blown fuse, determine why the fuse blew and make any necessary repairs. Failure to follow this procedure may result in serious damage to the tractor electrical system. Refer to the troubleshooting section of this manual or your Kubota dealer for specific information dealing with electrical problems.

If any of them should blow, replace with a new one of the same capacity.

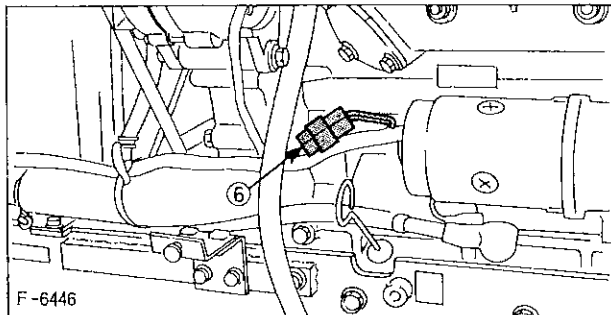
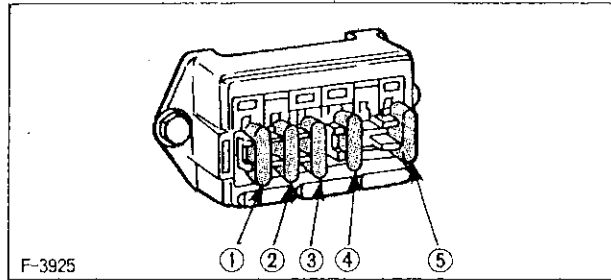

Protected circuit

- ① Fuse 1 (10A) Hazard light
- ② Fuse 2 (10A) Work light
- ③ Fuse 3 (15A) Head light (Tail light)
- ④ Fuse 4 (10A) Panel regulator
- ⑤ Fuse 5 (15A) Key stop
- ⑥ Slow blow fuse Check circuit against wrong battery connection.

Light Bulb Replacement

- (1) Head lights and Tail light
Take the bulb out of the light body and replace with a new one.
- (2) Other lights
Detach the lens and replace the bulb.

Head light	35W X 2	Panel light	3.4W
Hazard light	23W	Tail light	8W

11.11 RUBBER LINES AND HOSES

■ Check and Replacement

Check fuel lines and power steering hoses periodically. Replace them when they become deteriorated.

- (1) Check frequently to see that hose clamps are tight.
- (2) Air must be bled from fuel lines whenever they are removed.

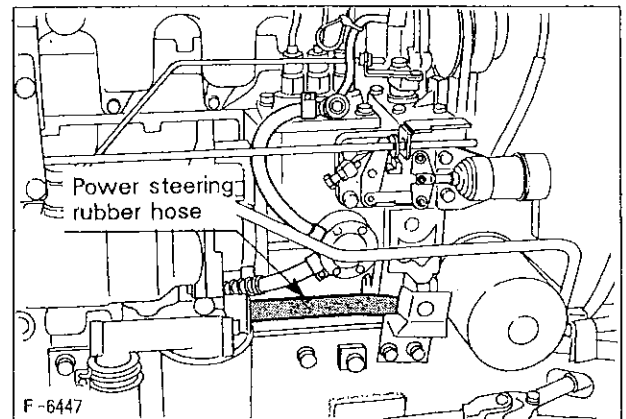
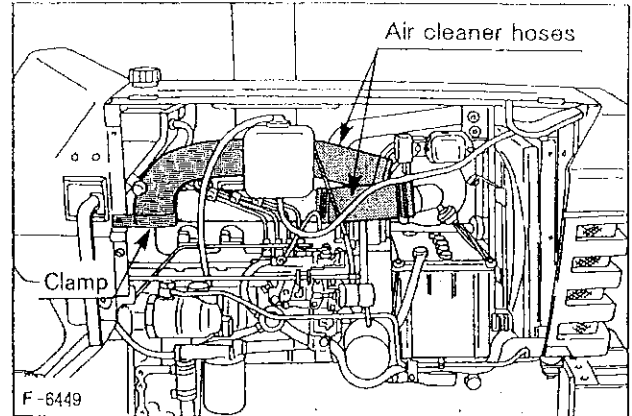
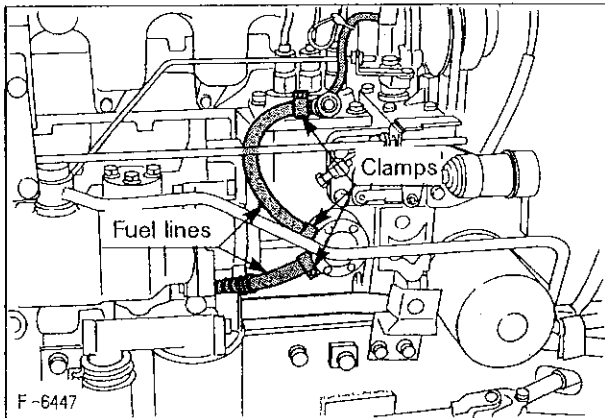
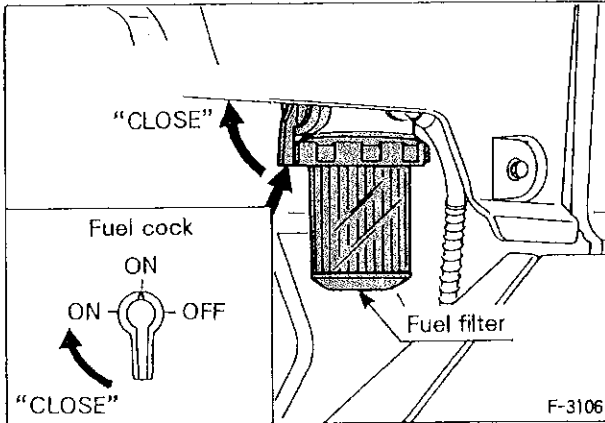

11.12 GREASING POINTS

Apply a small amount of multipurpose grease to the following points every 50 hours.

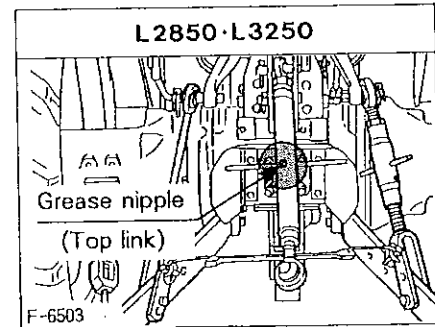
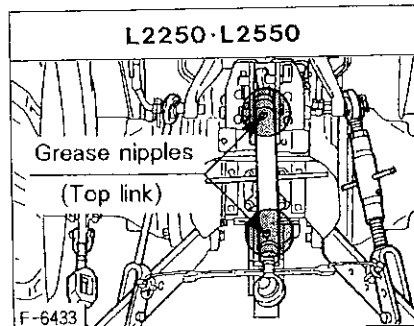
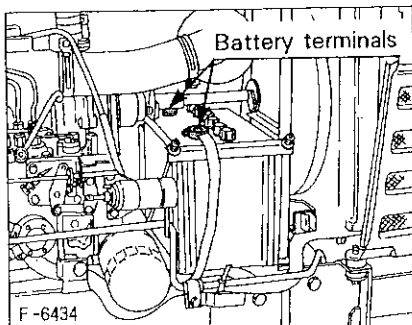
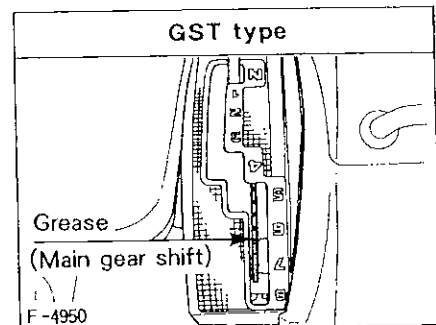
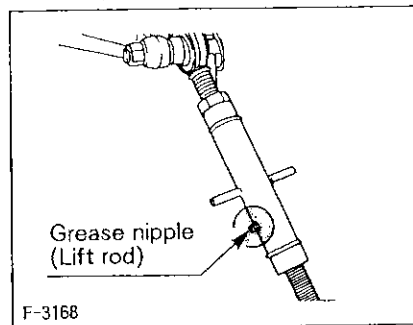
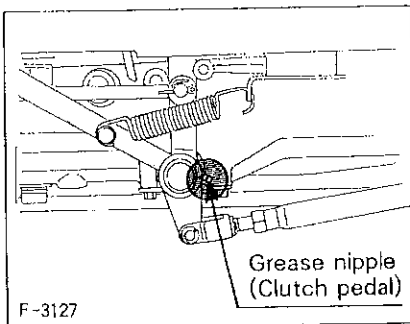
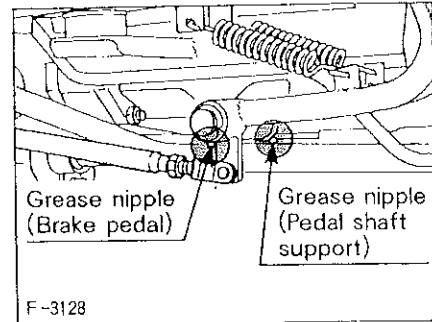
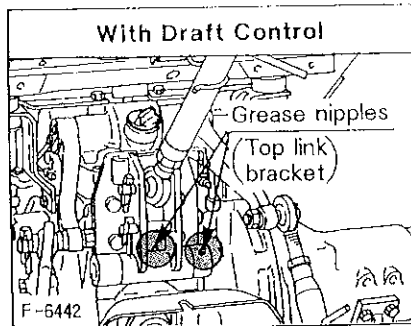
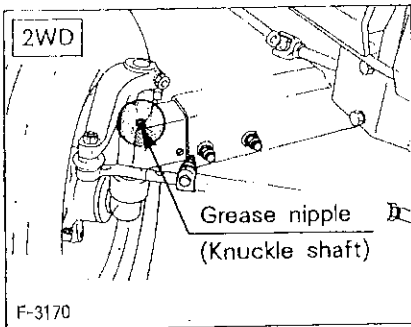

■ Front Wheel Hub [2WD]

Detach the cover, and apply bearing grease every 300 hours.

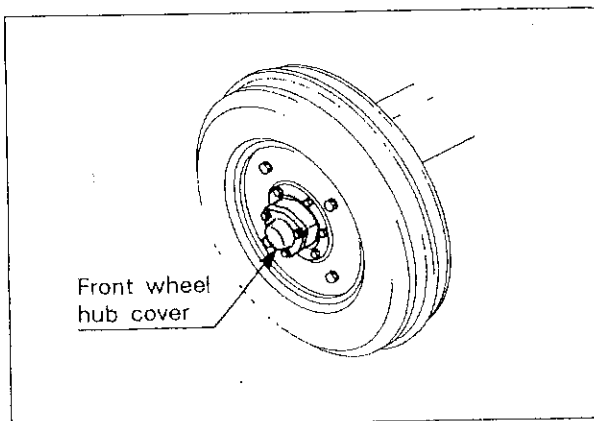

12. ADJUSTMENTS



CAUTION

To avoid personal injury:

- When making adjustments, park the tractor on flat ground, apply the parking brake, stop the engine and chock the wheels.

12.1 CLUTCH PEDAL CHECK AND ADJUSTMENT

Proper clutch pedal free travel	20 to 30 mm (0.8 to 1.2in.) on the pedal
---------------------------------	--

◆ Adjusting procedure [with Single Clutch, with GST]

- (1) Loosen the lock nut, and turn the turnbuckle to adjust the rod length.
- (2) Retighten the lock nut.

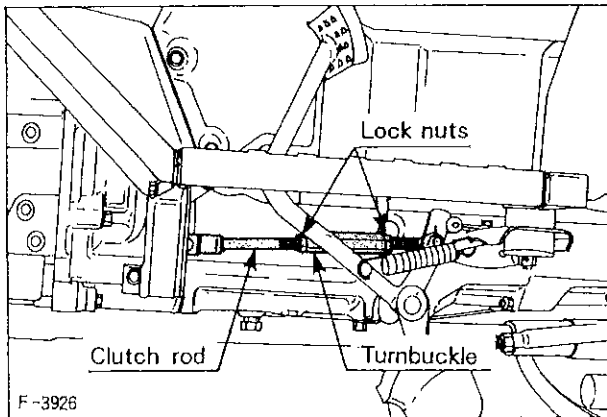

◆ Adjusting procedure [with Dual Clutch]

- (1) At first adjust clutch play, same as with single disc clutch.
- (2) Remove the cover located on the right side of fly-wheel housing case.
- (3) Loosen the lock nut, tighten the adjust bolt by using 6 mm (0.24 in.) spanner until head of the bolt contacts pressure plate slightly. Make 3/4 turn counterclockwise to give 0.9 to 1.0 mm (0.035 to 0.039 in.) clearance.

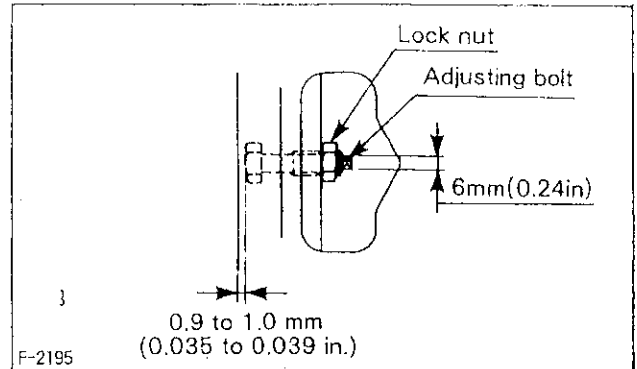

- (4) Tighten the lock nut, holding the adjusting bolt.
- (5) Repeat step one and readjust free-play if necessary.

12.2 BRAKE PEDAL CHECK AND ADJUSTMENT

Proper brake pedal free travel	20 to 30 mm (0.8 to 1.2in.) on the pedal
--------------------------------	--

IMPORTANT:

- Keep the free travel in the right and left brake pedals equal.

◆ Adjusting procedure

- (1) Release the parking brake rod.
- (2) Loosen the lock nut, and turn the turnbuckle to adjust the rod length.
- (3) Retighten the lock nut.

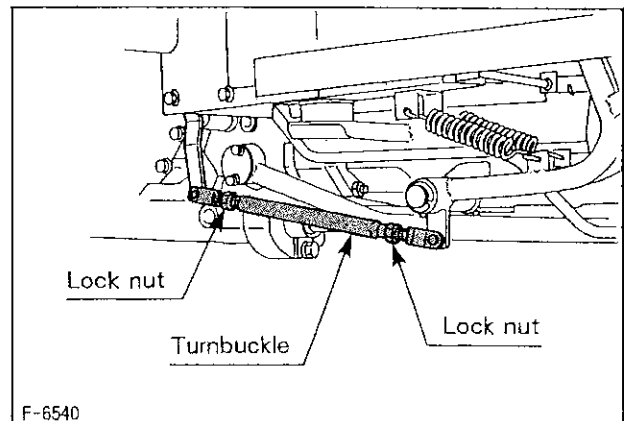

12.3 TOE-IN CHECK AND ADJUSTMENT

If the amount of toe-in is improper, such troubles as losing direction control and abnormal vibration may arise. Toe-in equals distances $C - D - A - B$, or 2 to 8mm (0.1 to 0.3 in.). To adjust toe-in loosen the lock nut and adjust the length of the rod until the proper toe-in measurement is obtained. Retighten the lock nut.

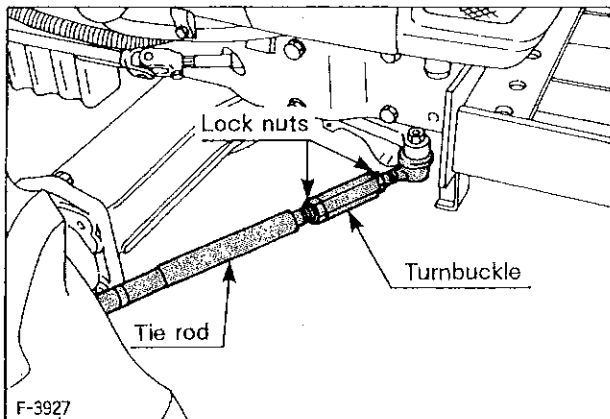
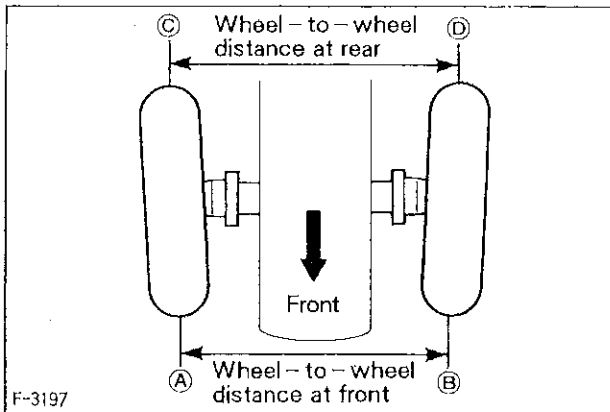

12.4 FAN BELT ADJUSTMENT

Proper fan belt tension	A deflection of about 7mm (0.3 in.) when the belt is pressed in the middle of the span.
-------------------------	---

◆ Adjusting procedure

Check the adjustment of the fan belt daily. When correctly adjusted the fan belt should have about 7mm (0.3 in.) of deflection in the middle of the longest span of the belt. To adjust the fan belt tension, loosen the alternator mounting bolts and, using a lever placed between the alternator and the engine block, pull the alternator out until the deflection on the longest span of the belt falls within acceptable limits.

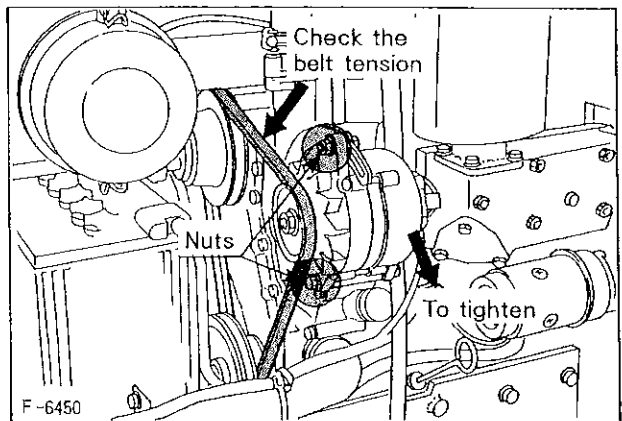

12.5 FRONT AXLE BACK-AND-FORTH PLAY ADJUSTMENT

If the back-and-forth play of the front axle is not proper, such trouble as abnormal front wheel vibration occurs and is transmitted to the steering wheel.

◆ Adjusting procedure

Loosen the lock nut, tighten the adjusting screw all the way, and then loosen the screw by 1/6 turn. Retighten the lock nut.

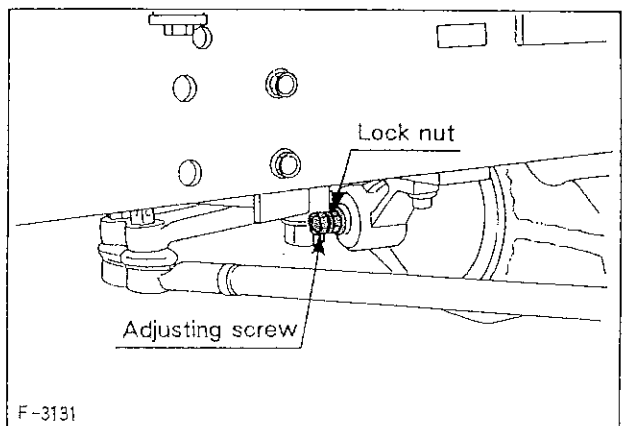

13. STORAGE



CAUTION

To avoid personal injury:

- To avoid the danger of exhaust fume poisoning, do not operate the engine in a closed building without proper ventilation.
- When storing, remove the key from the key switch to avoid unauthorized persons from operating the tractor and getting injured.

13.1 TRACTOR STORAGE

If you intend to store your tractor for an extended period of time, follow the procedures outlined below. These procedures will insure that the tractor is ready to operate with minimum preparation when it is removed from storage.

- (1) Check the bolts and nuts for looseness, and tighten if necessary.
- (2) Apply grease or engine oil to the tractor parts where rust collects easily.
- (3) Detach the additional weights from the tractor body.
- (4) Inflate the tires to a pressure a little higher than recommended for use.
- (5) Change the engine oil and run it to circulate oil throughout its block and internal moving parts for about five minutes.
- (6) Pull the engine stop knob all the way out.
- (7) Drain and flush the cooling system.
- (8) Keep the clutch disengaged. If the clutch is left engaged for a long period of time, the clutch plate may rust, making clutch disengagement impossible at the next operation.

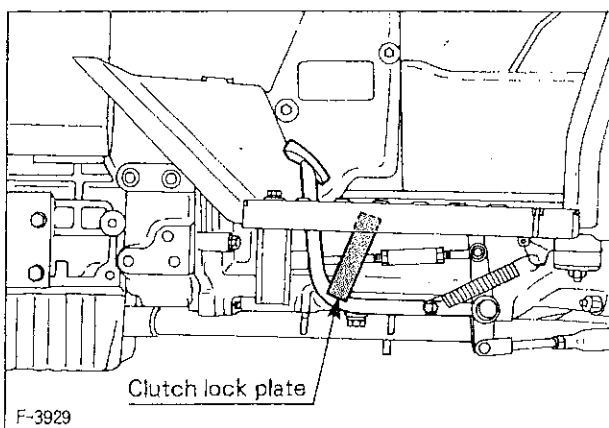

- (9) Keep the PTO gear shift lever at "NEUTRAL" position while tractor is stored for a long period of time.
- (10) With all implements lowered to the ground, coat any exposed hydraulic cylinder rods with grease.

- (11) Remove the battery from the tractor. Store the battery following the battery storage procedures outlined in the maintenance section of this manual.
- (12) Recharge the battery even while the tractor is in storage. The battery discharges itself even when not in use; recharge once a month in summer, and every two months in winter.
- (13) Keep the tractor in a dry place where the tractor is safe from rain. Cover the tractor.
- (14) Store the tractor indoors in a dry area that is protected from sunlight and excessive heat. If the tractor must be stored outdoors, cover it with a waterproof tarpaulin. Jack the tractor up and place blocks under the front and rear axles so that all four tires are off the ground. Keep the tires out of direct sunlight and extreme heat.

IMPORTANT:

- When washing the tractor, be sure to stop the engine. If the engine cannot be stopped, be careful not to allow water to get into the inlet port of the air cleaner. Water in the engine can cause severe trouble.
- Cover the tractor after the muffler and the engine have cooled down.
- During storage do not leave the key switch on.

13.2 REMOVING THE TRACTOR FROM STORAGE

- (1) Check the tire air pressure and inflate the tires if they are low.
- (2) Jack the tractor up and remove the support blocks from under the front and rear axles.
- (3) Install the battery. Before installing the battery, be sure it is fully charged.
- (4) Check the fan belt tension.
- (5) Check all fluid levels (engine oil, transmission / hydraulic oil, engine coolant and any attached implements).
- (6) Start the engine. Observe all gauges. If all gauges are functioning properly and reading normal, move the tractor outside. Once outside, park the tractor and let the engine idle for at least five minutes. Shut the engine off and walk around tractor and make a visual inspection looking for evidence of oil or water leaks.
- (7) With the engine fully warmed up, release the parking brake and test the brakes for proper adjustment as you move forward. Adjust the brakes as necessary.

14. ENGINE TROUBLESHOOTING

If something is wrong with the engine, refer to the table below for the cause and its corrective measure.

Trouble		Cause	Countermeasure
Engine is difficult to start.		1) No fuel flow.	<ul style="list-style-type: none"> ● Check the fuel tank and the fuel filter. Replace filter if necessary.
		2) Air and water are in the fuel system.	<ol style="list-style-type: none"> 1) Check to see if the fuel line coupler bolt and nut are tight. 2) Bleed the fuel system (See page 40).
		3) In winter, oil viscosity increases, and engine turning is heavy.	<ul style="list-style-type: none"> ● Use oils of different viscosities, depending on ambient temperatures.
		4) Battery becomes weak and the engine does not turn over fast enough.	<ol style="list-style-type: none"> 1) Charge the battery. 2) In cold weather, always remove the battery from the engine, charge and store it indoors. Install it on the tractor only when the tractor is going to be used.
Insufficient engine power.		1) Insufficient fuel.	<ul style="list-style-type: none"> ● Check the fuel system.
		2) The air cleaner is clogged.	<ul style="list-style-type: none"> ● Clean the element.
Engine stops suddenly.		Insufficient fuel.	<ol style="list-style-type: none"> 1) Refuel. 2) Bleed the fuel system if necessary.
Exhaust fumes are colored.	Black	1) Fuel quality is poor.	<ul style="list-style-type: none"> ● Change the fuel.
		2) Too much oil.	<ul style="list-style-type: none"> ● Check the proper amount of oil.
	Blue White	1) Nozzle trouble.	<ul style="list-style-type: none"> ● Check the nozzle.
		2) Fuel quality is poor.	<ul style="list-style-type: none"> ● Change the fuel.
Engine overheats.		1) Engine overloaded.	<ul style="list-style-type: none"> ● Shift to lower gear or reduce load.
		2) Low coolant level.	<ul style="list-style-type: none"> ● Fill cooling system to proper level; check radiator and hoses for loose connections or leaks.
		3) Loose or defective fan belt.	<ul style="list-style-type: none"> ● Adjust fan belt.
		4) Dirty radiator core or grille screens.	<ul style="list-style-type: none"> ● Remove all trash.
		5) Coolant flow route corroded.	<ul style="list-style-type: none"> ● Flush cooling system

If you have any questions, contact your Kubota dealer.

15. LUBRICANT SPECIFICATIONS

■ Engine Oil

Oil used in the engine should have an American Petroleum Institute (API) / SAE Classification of service CC or CD. The chart below shows the correct oil to be used at various temperature conditions:

ENGINE OIL VISCOSITY CHART

Below 0°C (32°F)	SAE 10W or 10W-30
0~25°C (32~77°F)	SAE 20 or 10W-30
Above 25°C (77°F)	SAE 30 or 10W-30

■ Others

Power steering	Multi-grade transmission fluid (Same as transmission fluid)
Front Wheel Bearings [2WD]	SAE lithium based grease
Chassis grease fittings	Multipurpose type grease
Front Wheel Drive Unit [4WD]	SAE 80 or 90 gear oil

■ Transmission Fluid

The fluid used to lubricate the transmission is also used as hydraulic fluid. To insure proper operation of the hydraulic system and complete lubrication of the transmission, it is important that a multi-grade transmission fluid be used in this system.

We recommend the use of KUBOTA UDT fluid for optimum protection and performance.

Also the following are recommended oils, by brand name, that may be used in the transmission hydraulic system.

Maker	Brand Name
Atlantic Richfield (ARCO)	Arco Tractor Fluid
Chevron	Tractor Hydraulic Fluid
Exxon	Torque Fluid 56
Penzoil	Hydra-Trans and Wet Br.
Phillips	H.T.Fluid
Shell	Donax TD,TT,TM
Texaco	T.D.H.Oil
Union	Hydraulic / Tractor Fluid
Gulf	Universal Fluid 425,350
Mobil	Mobil Fluid 423,350

KUBOTA LUBRICANTS

THE BEST CHOICE SINCE BUYING YOUR KUBOTA

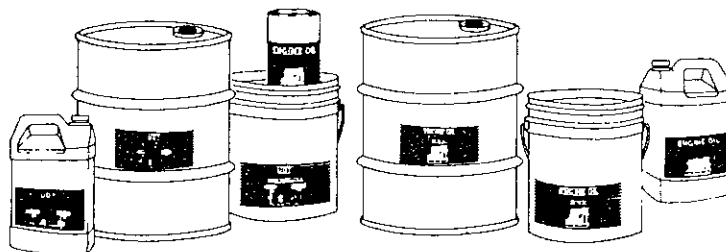

When you think of Kubota diesel tractors, you think of quality, performance and service. Now you can also think of Kubota lubricants.

Now, Kubota offers a lubricant line to use with all the Kubota tractors from 10 to 85 PTO horsepower. The Kubota lubricant line consists of a 15W-40 or 10W-30 engine oil and a universal transdrdraulic fluid called "UDT." A variety of sizes are available to meet your small and larger needs, in 1 quart, 2 gallon, 5 gallon and 55 gallon containers.

Next time you need to pour it on, pour it in with Kubota lubricants.

Kubota lubricants, tractor tough quality.

KUBOTA

Nothing like it on earth™

16. OPTIONS

Consult your KUBOTA dealer for detail.

- (1) SMV (Slow Moving Vehicle) Emblem
Recommended to forewarn overtaking traffic of tractor's presence.
- (2) Double Acting Remote Hydraulic Control Valve
- (3) Engine Precleaner
For extremely dusty conditions.
- (4) Engine Block Heater
For extremely cold weather starting.
- (5) Rear Work Light
High visibility for night work.
- (6) Suitcase Weights
55 lbs. each for front ballast.
- (7) Rear Wheel Weights
60 lbs. each for rear ballast.
- (8) Swing Drawbar
- (9) Draft Control
- (10) Under Muffler
- (11) Double Element Air Cleaner

17. WIRING DIAGRAM

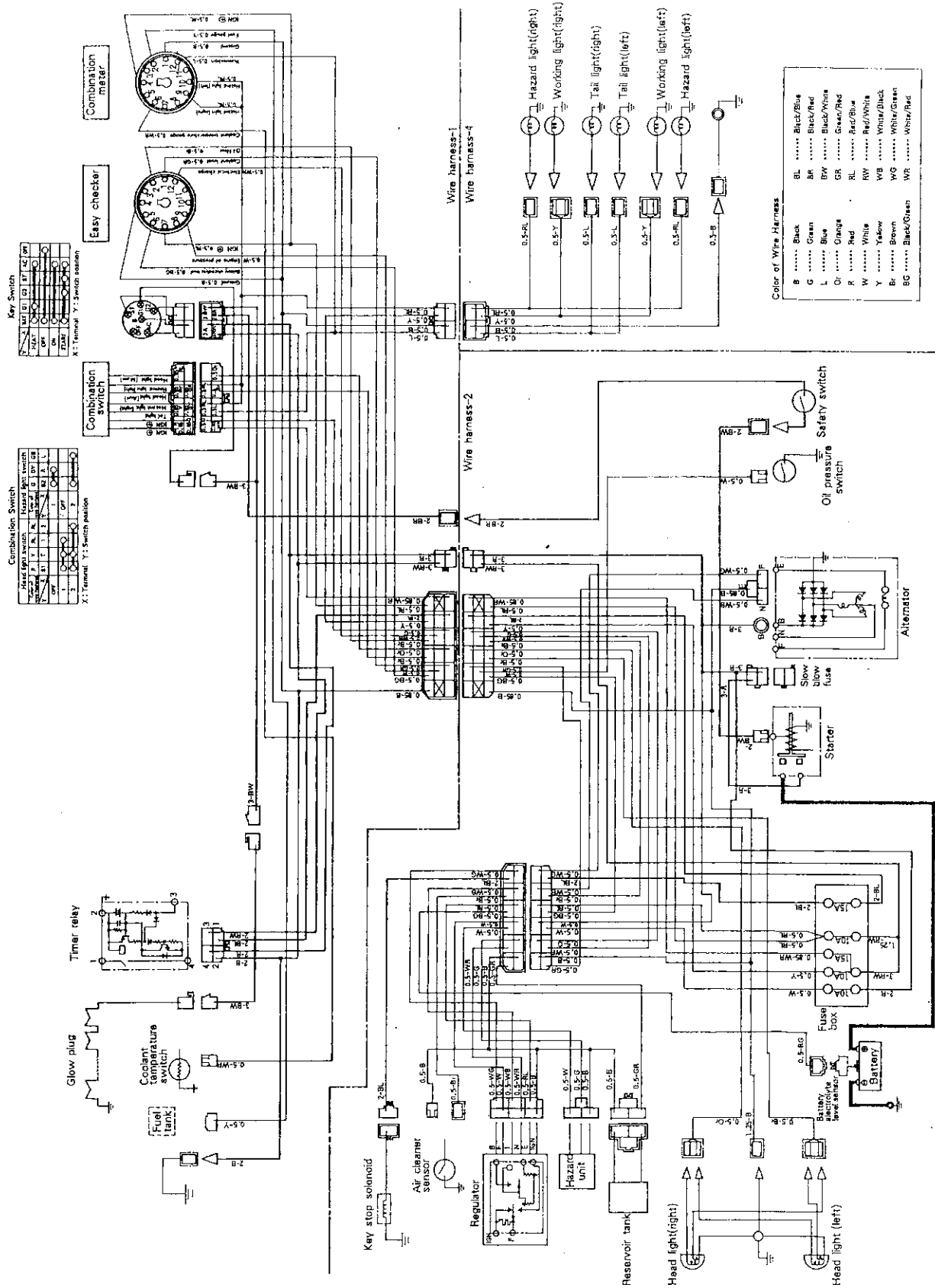

INDEX

A

Air cleaner	36,48
Air pressure	31
Anti-freeze	47

B

Ballast	32
Battery	36,49,50
Brake, adjustment	53
Brake pedals	19
Bulbs	50

C

Capacities	8,38
Check chains adjustment	24
Check, daily	37
Check, during driving	36
Clutch adjustment	53
Clutch pedal	19
Controls	14,16
Coolant	36,37

D

Daily check	37
Differential lock	21,35
Draft control	25
Drawbar	24,36
Driving the tractor on the road	2

E

Easy checker	15
Engine oil	42,57
Engine oil filter	43
Engine, starting	33
Engine stop	20,33,36
Engine troubleshooting	56

F

Fan belt	54
Front axle case	45
Front wheel drive lever	20
Fuel	40,41
Fuel bleeding	40
Fuel filter	41
Fuel gauge	15
Fuel tank capacity	40
Fuses	50

G

Greasing	52
----------------	----

H

Hazard light switch	14
Head light switch	14
Hi-Lo gear shift lever	17
Horn button	14
Hoses	51
Hour meter	15
Hydraulic control reference chart	27
Hydraulic oil filter	45
Hydraulic oil paper filter	45

I

Implement limitations	11,12
Inflation pressure	31
Instrument panel	14

J

Jump starting instructions and precautions	4
--	---

K

Key switch	14
------------------	----

L

Lift rod adjustment	24
Liquid weight	32
Loading and unloading	13
Lubricants	38,57

M

Magnetic plug	44
Main shift lever	17,18
Maintenance check list	39

O

Operating the PTO	3
Operation, draft control	25
Operation, engine	33
Operation, tractor	13,34
Options	58

P

Parking brake rod	19
Position control	25
Power steering	35,46
PTO operation	22
PTO, safe operation	3
Pulling	36

R

Radiator	46
ROPS (Roll-Over Protective Structures)	1

S

Safety	1
Safety labels	5, 6
Seat	21
Serial number	7
Servicing of tractor	7
Shifting transmission	17
Shuttle shift lever	17,18
SMV (Slow Moving Vehicle) emblem	2
Specification	8
Starting engine	33
Stopping engine	20,33,36
Switches	14

T

Temperature gauge	15
Three-point hitch	24
Three-point hitch lowering speed	25
Throttle lever	20
Throttle pedal	20
Tire service	31
Toe-in adjustment	54
Top link adjustment	24
Tractor operation	13,34
Tractor starting	34
Tractor stop	35
Tractor storage	55
Transmission fluid	43
Transmission shifting	17
Traveling speeds	10
Tread adjustment	29

W

Warm-up	34
Wheel hub	31
Wheels, front	28,29
Wheels, rear	30
Wiring diagram	59