

# ISEKI TRACTORS

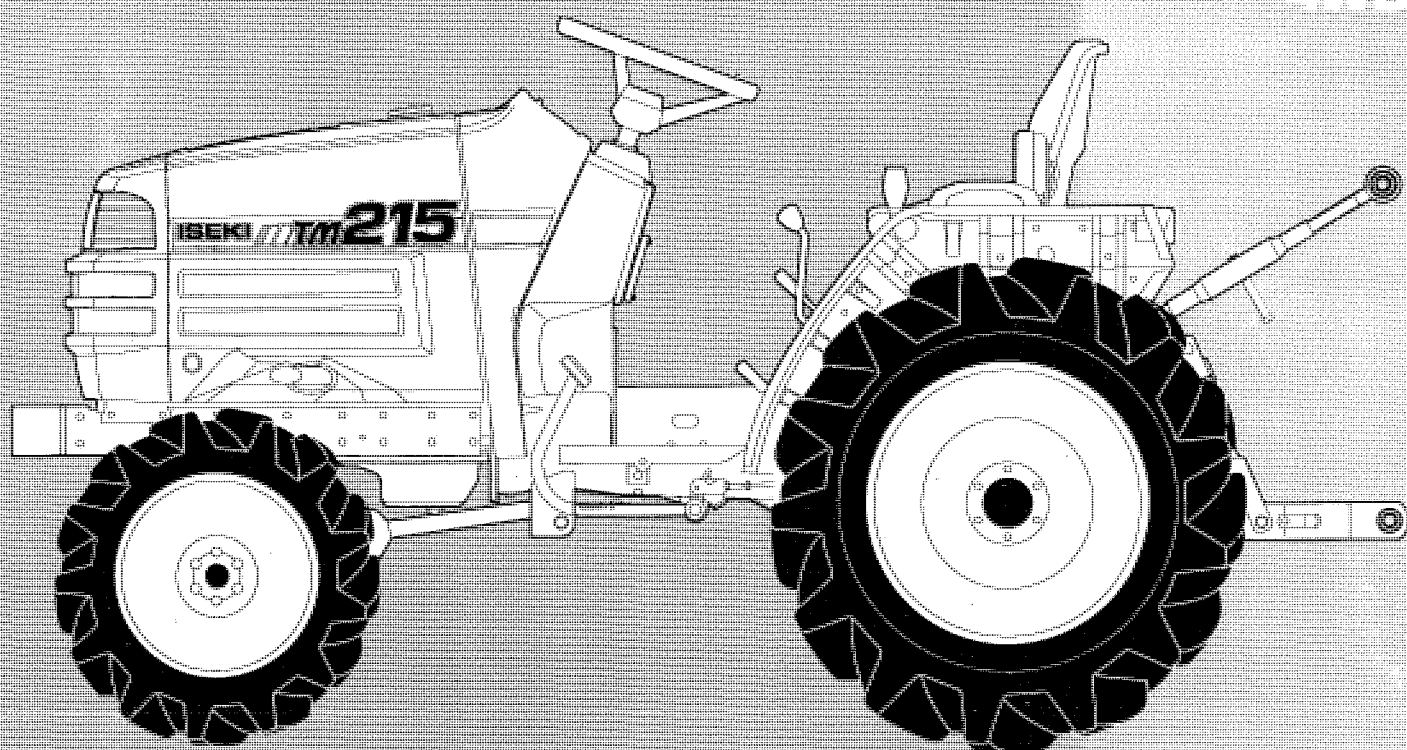
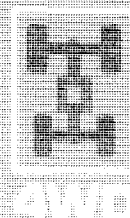

## Operation Manual

***TM215F***  
***TM217F***  
***TM223F***

**ISEKI & CO., LTD.**

## TO OUR CUSTOMER

Thank you very much for purchasing an ISEKI tractor.

This operator's manual provides the information necessary for operating and maintaining your tractor safely and properly. The contents are mainly composed of the following two items:

Safety instructions : Essential items which you should observe while operating the tractor

Technical instructions : Items which are necessary to operate, adjust, and service the tractor properly

Before starting to operate the machine for the first time, you should read this operation manual thoroughly and carefully until you are sufficiently familiar with the operation of the machine to do jobs safely and properly. The manual should be kept in a handy place so you can refer to it when required. You are advised to refer to it from time to time to refresh your understanding of the machine.

Your dealer has performed the pre-delivery service on your new machine. He will discuss with you the operating and maintenance instructions given in this manual, and instruct you in the proper and varied applications of this machine. Call on him at any time when you have a question, or need equipment related to the use of your machine.



*Paragraphs in the manual and labels on the machine which are accompanied by a caution mark contain particularly important information about safe operation to avoid accidents. You should always keep precautions in mind and follow them during operation.*

**Be sure to wear  
personnel protective equipment  
during operation!**



*In some of the illustrations used in this operation manual, panels or guards may have been removed for clarity. Never operate the tractor with these panels and guards removed. If the removal of a shield is necessary to make a repair, it must be replaced before operation.*

*All information, illustrations, and specifications contained in this manual are based on the latest information available at the time of publication. The right is reserved to make changes at any time without notice.*

# TABLE OF CONTENTS

|  |           |  |           |
|--|-----------|--|-----------|
| <b>TO OUR CUSTOMER</b> .....                   | 1         | ENGINE SPEED CONTROLS .....  | 25        |
| <b>TABLE OF CONTENTS</b> .....                 | 2         | TRAVEL CONTROL LEVERS .....  | 26        |
| <b>SAFETY</b> .....                            | 4         | PTO SWITCH .....   | 26        |
| MAKING YOUR TRACTOR A SAFE VEHICLE .....       | 4         | REMOTE HYDRAULIC CYLINDER CONTROL SWITCH (OPTION) .....                | 27        |
| ■ HOW TO MAINTAIN SAFETY .....                 | 4         | OTHER CONTROLS .....   | 27        |
| ■ DIMENSIONAL LIMITS OF IMPLEMENTS .....       | 5         | <b>OPERATION</b> .....   | <b>28</b> |
| FOR SAFE OPERATION .....                       | 6         | BREAK-IN PERIOD .....  | 28        |
| ■ HOW TO BE A SAFE OPERATOR .....              | 6         | STARTING .....   | 28        |
| ■ WHEN ANOTHER PERSON OPERATES .....           | 7         | Pre-Start Inspection .....   | 28        |
| ■ BEFORE OPERATION .....                       | 7         | Normal Starting .....  | 29        |
| ■ STARTING ENGINE AND MOVING TRACTOR .....     | 8         | Restarting Warm Engine .....   | 30        |
| ■ WHEN TRAVELLING .....                        | 8         | Cold Weather Starting .....  | 30        |
| ■ LOADING ONTO OR UNLOADING FROM A TRUCK ..... | 10        | Warm-Up Period .....   | 31        |
| ■ DURING OPERATION .....                       | 11        | Operator Observations .....  | 31        |
| ■ INSPECTION AND MAINTENANCE .....             | 12        | MECHANICAL TRANSMISSION .....  | 32        |
| ■ STORAGE .....                                | 13        | Ground Speed Selection .....   | 32        |
| MAINTENANCE OF THE ELECTRIC SYSTEM .....       | 14        | Stopping Tractor .....   | 33        |
| ■ TO MAINTAIN ELECTRIC WIRING .....            | 14        | HYDROSTATIC TRANSMISSION .....   | 33        |
| ■ TO HANDLE THE BATTERY .....                  | 14        | Ground Speed Selection .....   | 33        |
| ■ TO HANDLE BOOSTER CABLES .....               | 15        | Stopping Tractor .....   | 34        |
| ■ SAFETY DECALS .....                          | 15        | DIFFERENTIAL LOCK OPERATION .....                                      | 35        |
| ■ SAFETY DECALS AND THEIR LOCATION .....       | 16        | FOUR-WHEEL DRIVE .....   | 36        |
| <b>TRACTOR IDENTIFICATION</b> .....            | <b>17</b> | POWER TAKE-OFF (PTO) .....   | 37        |
| MODEL/SERIAL NUMBERS .....                     | 17        | Rear PTO Shaft .....   | 37        |
| <b>MAJOR COMPONENTS</b> .....                  | <b>18</b> | Mid PTO Shaft .....  | 38        |
| <b>INSTRUMENTS &amp; CONTROLS</b> .....        | <b>19</b> | PTO OPERATING CONTROLS .....   | 38        |
| INSTRUMENT PANEL .....                         | 20        | THREE-POINT HITCH .....  | 41        |
| Electrical Fuel Shut-Off .....                 | 21        | Hitch Controls .....   | 41        |
| Main Switch .....                              | 21        | Rear Linkage .....   | 42        |
| Indicator Light Strip .....                    | 22        | Attaching implements .....   | 43        |
| Tachometer .....                               | 23        | Using Position Control .....   | 44        |
| SWITCHES .....                                 | 23        | Detaching Implements .....   | 45        |
| MAIN CLUTCH PEDAL .....                        | 24        | <b>LUBRICATION &amp; PERIODIC MAINTENANCE</b> .....                    | <b>47</b> |
| BRAKES .....                                   | 24        | SPECIFICATIONS & CAPACITIES .....                                      | 47        |
| Brake Pedals .....                             | 24        | Engine Oil .....   | 47        |
| Parking Brakes .....                           | 25        | Engine Coolant .....   | 47        |
|  |           | Fuel Tank .....  | 47        |
|  |           | Transmission & Differential Housing (Including Hydraulic System) ..... | 47        |

|  |           |   |           |
|--|-----------|---|-----------|
| Front Axle .....                                   | 47        | <b>SPECIFICATIONS .....</b>                         | <b>75</b> |
| Grease Fittings .....                              | 47        | SPECIFICATIONS .....                                | 75        |
| LUBRICATION/FILL POINTS .....                      | 48        | Engine .....  | 75        |
| PERIODIC MAINTENANCE SCHEDULE .....                | 49        | Transmission .....                                  | 75        |
| SERVICE ACCESS .....                               | 50        | Power take-off (PTO) .....                          | 75        |
| LUBRICATION DETAILS .....                          | 50        | Hydraulics .....                                    | 75        |
| Grease Fittings .....                              | 50        | Electrical system .....                             | 76        |
| Engine Oil & Filter .....                          | 51        | Capacities .....                                    | 76        |
| Transmission Oil & Filters .....                   | 52        | Track setting .....                                 | 76        |
| Hydrostatic Cartridge Oil Filter Replacement ..... | 54        | Maximum axle loading .....                          | 76        |
| Front Axle Oil .....                               | 54        | Tyre size .....                                     | 76        |
| COOLING SYSTEM .....                               | 55        | GENERAL DIMENSIONS .....                            | 77        |
| ENGINE AIR CLEANER .....                           | 56        | <b>ASSEMBLY &amp; PRE-DELIVERY INSPECTION .....</b> | <b>78</b> |
| FUEL SYSTEM .....                                  | 57        | <b>WIRING DIAGRAM .....</b>                         | <b>89</b> |
| Fuel Filter .....                                  | 57        |   |           |
| Air-bleeding Procedure .....                       | 58        |   |           |
| Throttle Lever .....                               | 59        |   |           |
| ELECTRICAL SYSTEM .....                            | 60        |   |           |
| Battery .....                                      | 60        |   |           |
| Safety Switches .....                              | 61        |   |           |
| Wiring/Fuse Arrangement .....                      | 62        |   |           |
| WIRING DIAGRAM .....                               | 63        |   |           |
| CLUTCH FREE-PLAY ADJUSTMENT .....                  | 63        |   |           |
| BRAKE FREE-PLAY ADJUSTMENT .....                   | 64        |   |           |
| WHEELS & TYRES .....                               | 66        |   |           |
| Tyre Inflation Pressures .....                     | 66        |   |           |
| Front Wheel Spacing .....                          | 66        |   |           |
| Rear Wheel Spacing .....                           | 67        |   |           |
| Steering Free-Play .....                           | 67        |   |           |
| Front Axle End-Float .....                         | 68        |   |           |
| CLUTCH HOUSING PLUG .....                          | 68        |   |           |
| TORQUE CHART .....                                 | 68        |   |           |
| STORAGE .....                                      | 68        |   |           |
| <b>TROUBLESHOOTING .....</b>                       | <b>70</b> |   |           |
| Engine .....                                       | 70        |   |           |
| Clutch .....                                       | 72        |   |           |
| Brakes .....                                       | 72        |   |           |
| Hydraulic System .....                             | 72        |   |           |
| Steering System .....                              | 73        |   |           |
| Electrical System .....                            | 73        |   |           |

## **SAFETY**

Understand thoroughly the following precautions, always keep them in mind before, during, and after operation, and never take chances.

### **MAKING YOUR TRACTOR A SAFE VEHICLE**

#### **■ HOW TO MAINTAIN SAFETY**

(1) Never attempt to do the following:

- Modification of the structure of the tractor
- Installation of other type engine
- Installation of tyres of other than the original tyre size

Any malfunctions or failures of the tractor due to unauthorized modification are not covered by the warranty.

(2) This machine cannot be driven on a public road without authorization by a local government agency, etc.

When transporting an unauthorized machine on a public road, load it on a truck.

When travelling with an implement wider than the tractor, put red caution markers such as flags (red lamps at night) in the most visible locations on both sides of the implements, and place a "SLOW MOVING VEHICLE" sign in a place where it is easily seen by other drivers. Operate the machine carefully keeping in mind that the implement is wide and may roll easily. If the implement can be folded, fold it beforehand. If there are road or railway crossings where the visibility is poor, you should install on the machine a mirror to give a view ahead of you so that you need not move your machine too far into the intersection.

(3) When you travel on a road, you must turn work lights off if the law requires it.

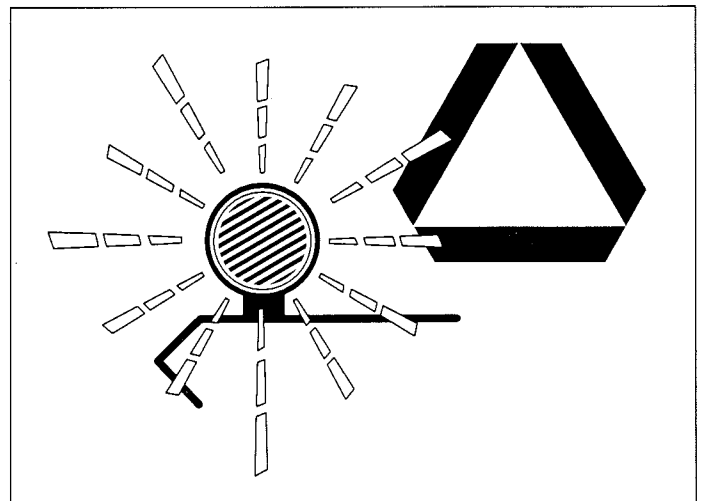

**■ DIMENSIONAL LIMITS OF IMPLEMENTS**

| Implement                               | Items                      | TM217F<br>TM215F<br>TM223F                 |
|---|----------------------------|--|
| <b>Rotary mower</b> .....               | Front-mount .....          | Max. cutting width ..... 1,300 mm          |
|   | (2, 3 blades)              | Max. weight ..... 100 kg                   |
|   | Mid-mount .....            | Max. cutting width ..... 1,370 mm          |
|   | (2, 3 blades)              | Max. weight ..... 150 kg                   |
|   | Rear-mount .....           | Max. cutting width ..... 1,070 mm          |
|   | (1 blade)                  | Max. weight ..... 150 kg                   |
| <b>Rotary tiller</b> .....              | Mid-mount .....            | Max. cutting width ..... 1,520 mm          |
|   | (2, 3 blades)              | Max. weight ..... 150 kg                   |
| <b>Rotary tiller</b> .....              | Max. tilling width .....   | 1,070 mm                                   |
|   | Max. weight .....          | 150 kg                                     |
| <b>Bottom plough</b> .....              | Max. size .....            | 360 mm x 1                                 |
| <b>Disk plough</b> .....                | Max. size .....            | 560 mm x 1                                 |
| <b>Cultivator</b> .....                 | Max. size .....            | 1,370 mm                                   |
|   | Max. weight .....          | 150 kg                                     |
| <b>Disk harrow</b> .....                | Max. harrowing width ..... | 1,400 mm                                   |
|   | Max. weight .....          | 150 kg                                     |
| <b>Sprayer</b> .....                    | Max. tank capacity .....   | 120 litres                                 |
| <b>Broad caster</b> .....               | Max. tank capacity .....   | 120 litres                                 |
| <b>Sand spreader</b> .....              | Max. tank capacity .....   | —  |
| <b>Front blade with sub-frame</b> ..... | Max. cutting width .....   | 1,250 mm                                   |
| <b>Rear blade</b> .....                 | Max. cutting width .....   | 1,520 mm                                   |
|   | Max. weight .....          | 150 kg                                     |
| <b>Box blade</b> .....                  | Max. cutting width .....   | 1,070 mm                                   |
|   | Max. weight .....          | 150 kg                                     |
| <b>Snow blower with sub-frame</b> ..... | Max. cutting width .....   | 1,220 mm                                   |
|   | Max. weight .....          | 130 kg                                     |
| <b>Trailer</b> .....                    | without brake .....        | Max. load capacity ..... 300 kg            |
| <b>3-point lift</b> .....               | Front .....                | Max. load capacity ..... 150 kg            |
|   | Rear .....                 | Max. load capacity ..... 200 kg            |
| <b>Weight</b> .....                     | Front wheel .....          | Max. load capacity ..... 0 kg              |
|   | Rear wheel .....           | Max. load capacity ..... 80 kg             |
|   | Bumper .....               | Max. load capacity ..... 90 kg (6 weights) |
| <b>Cabin</b> .....                      | Max. weight .....          | 150 kg                                     |

## **FOR SAFE OPERATION**

### **■ HOW TO BE A SAFE OPERATOR**

(1) Familiarize yourself fully with machine controls by studying the operation manual before using your machine.

(2) Never allow persons listed below to operate the machine.

- Persons with mental disease
- Persons who cannot operate the machine properly because of fatigue, illness, or drowsiness from medication, etc.
- Pregnant women
- Young persons or children too young to legally operate the machine

Always be careful of your health by taking suitable rest breaks.

(3) Wear appropriate clothing and other protective devices during operation.

- Protection of your head

Wear protective headgear such as a helmet, especially when travelling on roads or handling material above your head.

- Protection to avoid being caught in the machine  
Wear tightfitting clothing and headgear, because loose clothing or hair can get caught in the moving parts of the machine.

- Protection from poisonous dust or gases

Be sure to wear a protective device to protect the respiratory system, eyes, and skin when handling poisonous chemicals.

- Protection of the ears

Wear ear plugs or take suitable countermeasures to protect your ears when you must operate the machine under extremely noisy conditions.

- Maintenance of protective devices

Periodically inspect protective devices to assure that they are functioning properly. Use them at all times.

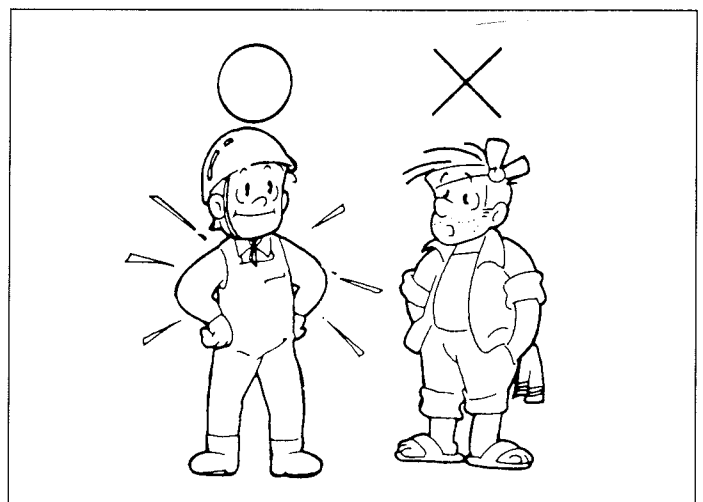

## ■ WHEN ANOTHER PERSON OPERATES YOUR MACHINE

When another person operates your machine, you must explain how to operate and instruct him or her to read this manual fully to avoid unexpected accidents.

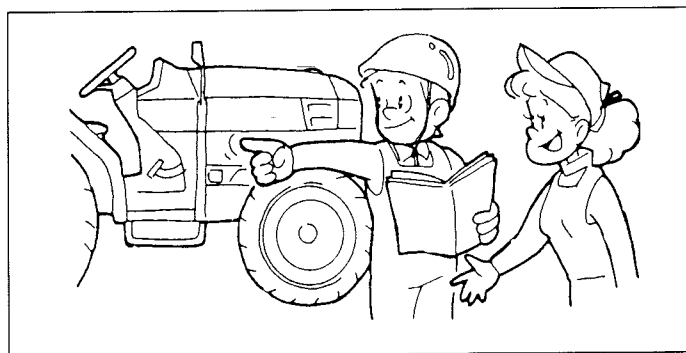

## ■ BEFORE OPERATION

(1) Set up an operation plan with sufficient time allowance. A tight plan may result in unexpected accidents in a hurry when work has to be rushed.

(2) Inspect and service the machine periodically in accordance with the instructions given in the operation manual to maintain the machine in best condition.

Pay special attention to the controls, especially to the brakes and clutch, and safety measures for the machine when servicing it. If the machine functions properly and performs normally, the chance of an accident will be reduced greatly.

If safety devices are damaged or do not work, please consult your ISEKI dealer.

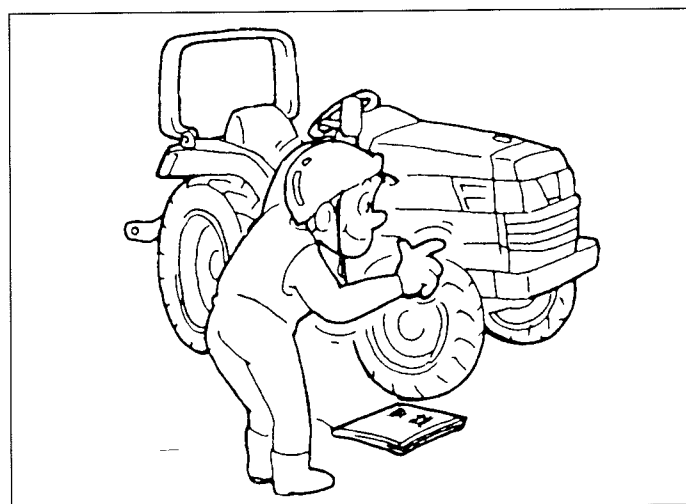

(3) Before removing a safety device, such as a safety cover, be sure that the machine has stopped completely. Never forget to replace the removed part after servicing.

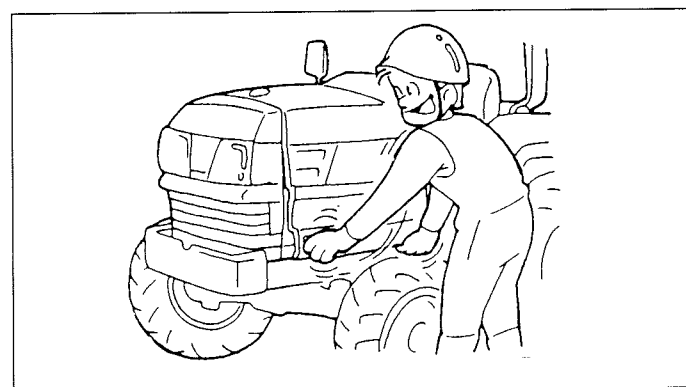

(4) Never inject fuel while the engine is running or is still hot. Keep away from open fires and never smoke around a fuel tank or while fuelling the machine. Never use open flames for illumination when fuelling the machine at night.

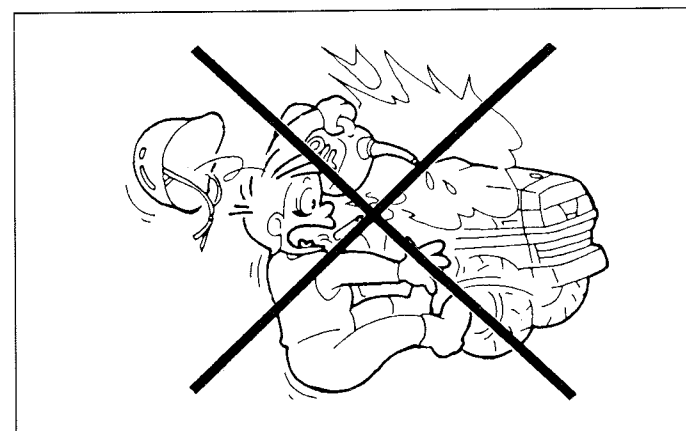

■ **STARTING ENGINE AND MOVING TRACTOR**

- (1) Before starting the engine indoors, make sure that there is proper ventilation because exhaust fumes contain poisonous carbon monoxide, which cause lethal poisoning.
- (2) Before starting the machine, confirm that the transmission gear has been shifted to the appropriate speed, that there is no one near the machine, and that the implement is securely installed on the machine.

Always operate the machine from the operator's seat. Never leave the seat except in an emergency when operating the machine.

- (3) Before starting to move, pay attention to safety conditions around the machine to avoid injury to bystanders or damage to property. Never move abruptly.

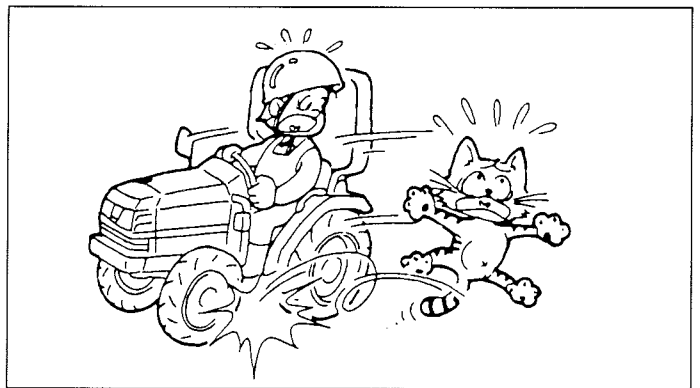
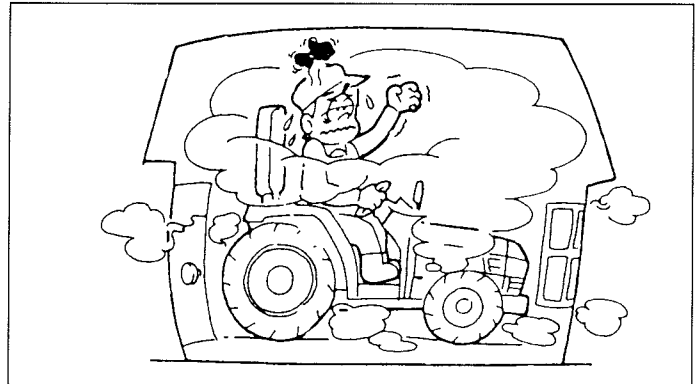

■ **WHEN TRAVELLING**

- (1) When you travel on roads, latch the brake pedals together by using the interlocking plate, or the tractor may turn over by one wheel locking. (Mechanical transmission)
- (2) When you travel on roads, ensure the differential lock is off, or the tractor may turn over.
- (3) Do not make sharp turns when operating at high speed or for transportation, as the tractor may turn over.
- (4) When operating on poor footing such as a rough road, a slope, a road along a ditch or river, or undeveloped land, drive the tractor at low speeds and operate it carefully.
- (5) Do not make sharp turns on a slope. It may cause turnover of the tractor.  
When climbing up a hill, shift the speed change lever to the most suitable speed. Start moving the tractor as slowly as possible.  
While climbing up a hill, never shift speeds along the way

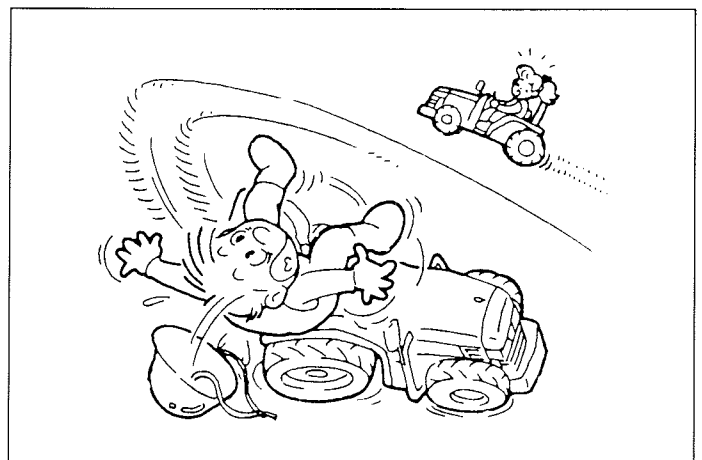
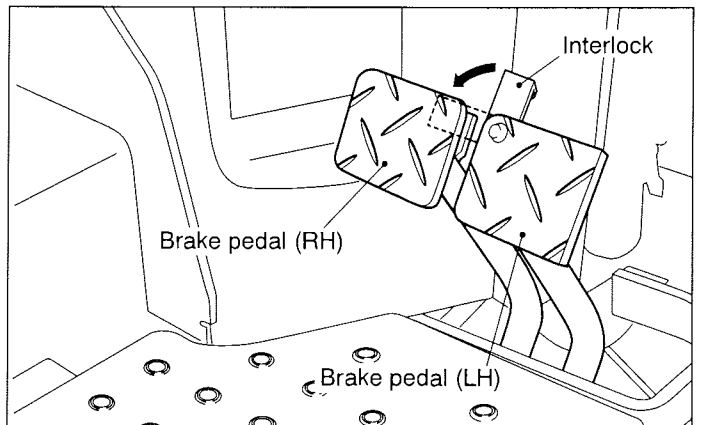

When starting to move the tractor on an up-hill slope, be sure that the front wheels do not lift up. When going down a hill, drive the tractor at a slower speed than used to climb up the hill. While going down a hill, never disengage the clutch or shift into neutral, and never try to control the speed only with the brakes; use the engine brake effectively.

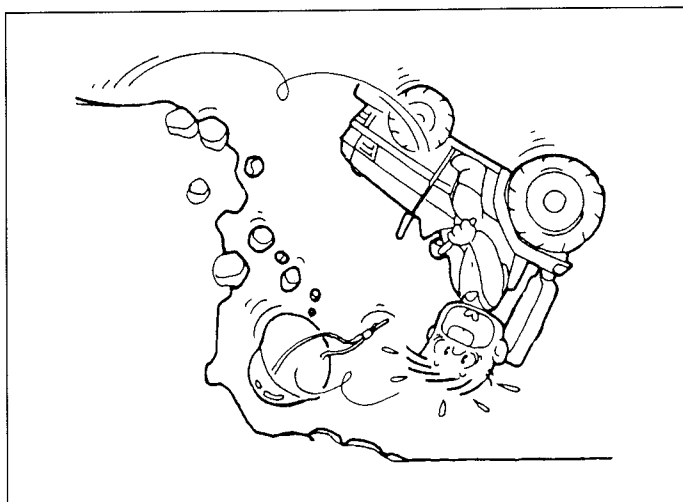

- (6) When travelling on a road where one or both shoulders are slanted and which run along a ditch, look out for softened shoulders especially when the ditch is full of water and be careful not to let the machine slip sideways.

- (7) Never allow other persons to get on the machine or the implement except when the machine or the implement is provided with a seat or a platform for persons to sit or stand on, and only within the capacity specified. Never allow persons to get on the implement while travelling on roads.

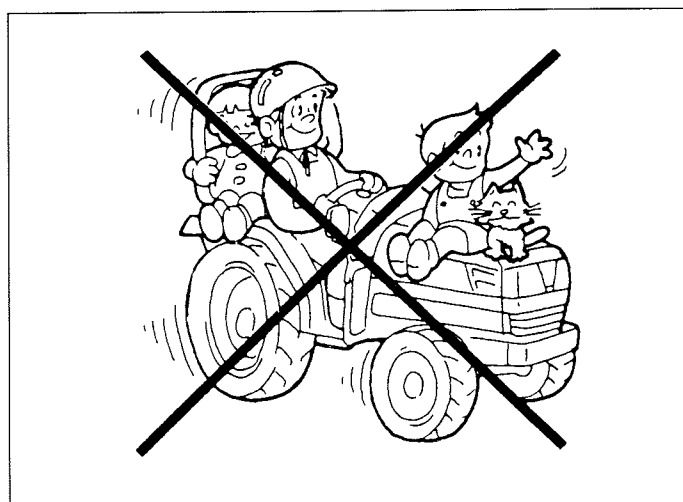

- (8) When parking the tractor, you have to park it on hard, level ground and provide sufficient safety measures by grounding the implement, removing the key, applying the parking brakes, and chocking the wheels securely.

- (9) Keep inflammables away from the engine during operation. Especially during stationary operation do not operate the engine at high speed so as not to set fire to grass or straw with a heated exhaust pipe or exhaust fumes.

- (10) When you have to operate the tractor at night, make sure of location of controls. If not, the tractor might work unexpectedly by mistake. When travelling on roads, never turn on the work lamps (option).

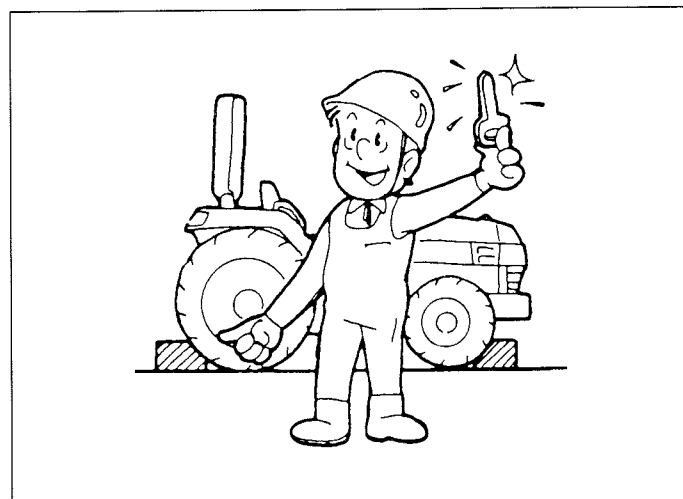

■ **LOADING ONTO OR UNLOADING FROM A TRUCK**

- (1) When loading the tractor onto a truck or a trailer, turn off the truck's engine and apply the parking brakes to the truck or the trailer. Otherwise, the truck could move and the tractor fall to the ground.
- (2) Pay sufficient attention to the safety conditions around the tractor and have it guided by someone to assist the operation. Never allow other persons to approach the tractor, especially in front of or behind it.
- (3) When loading or unloading the machine on/off a track, set slip-proof ramps at the same angles and drive the tractor straight at sufficiently slow speeds. Loading the tractor in reverse travel and unloading it in forward travel.
- (4) Be sure to interlock the right and left brake pedals ahead of time. Never depress the brake pedals or clutch pedal during loading or unloading operation, or the tractor may shift sideways, which may cause it to fall off the ramps.
- (5) If the engine stalls unexpectedly on the ramps, depress the brake pedals immediately and roll the tractor to the ground by manipulating the brake pedals. Start the engine on the ground and try again.
- (6) When the machine is loaded on the truck, stop the engine, apply parking brakes, and withdraw the starter key, chock the wheels, and rope it securely to the truck. During transportation, do not make sharp turns needlessly so as not to shift the loaded tractor.
- (7) Use ramps with the same or better specifications mentioned below. When the machine is equipped with attachments other than those included in the specifications mentioned below, ask your ISEKI dealer for advice.

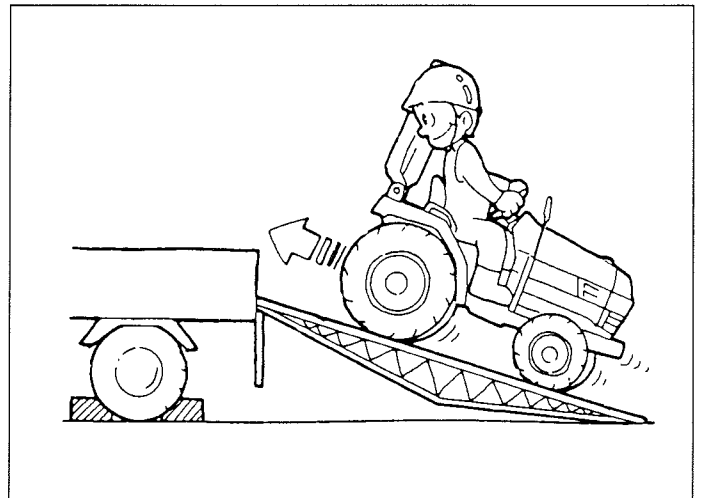

**Specifications of the ramps**

- Length more than 4 times the height of the platform of the truck
- Width (effective width) ..... more than 35 cm
- Capacity (one ramp) ..... more than 1000 kg
- Ramps should have anti-skid surfaces

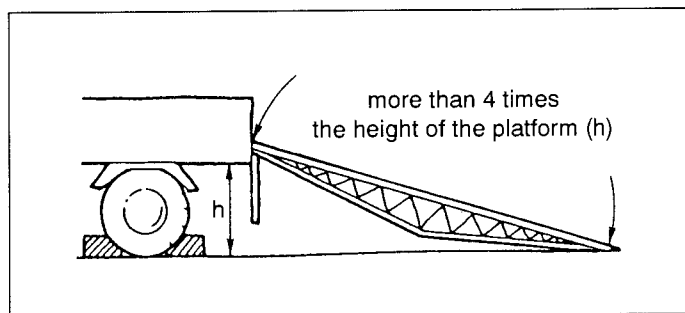

- (8) Hook the ramps securely on the platform of the truck with the top of the ramp level with the platform.
- (9) Always prepare for even the worst, never allowing other persons near the tractor.
- (10) Drive the tractor carefully at the moment the tractor moves from the ramps onto the platform, for it changes angle abruptly.

**■ DURING OPERATION**

- (1) During operation, never allow other persons in the vicinity of the tractor, because the tractor itself or flung pieces may cause injury.
- (2) Pay attention to safety around the tractor to avoid injury to bystanders or damage to property. Especially when operating with other persons, use the horn to warn them.
- (3) When crossing a ditch or a levee or when passing through soft land, drive the tractor slowly and straightforward so that it does not slip or turn over.
- (4) Do not touch dangerous parts such as rotating parts, moving parts, hot parts (muffler, radiator, or engine, etc.), or electric parts (battery terminals and other live parts), or you may be injured seriously.
- (5) If you use a trailer, use a proper one which starts your tractor. Using an improper trailer may cause serious accidents. Never attempt to haul beyond the tractor's capacity. If you have a question, please consult your ISEKI dealer.

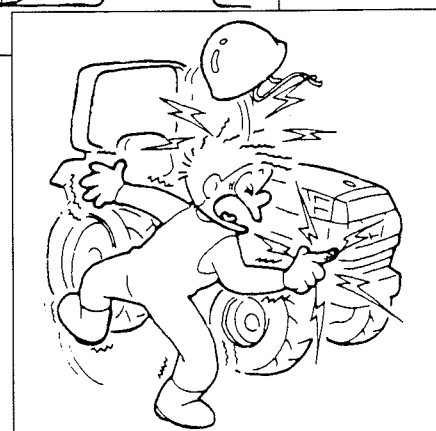
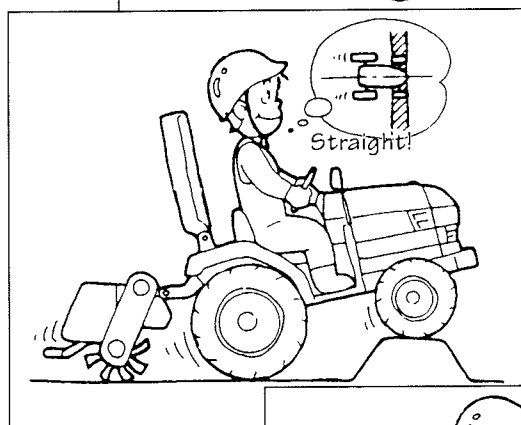
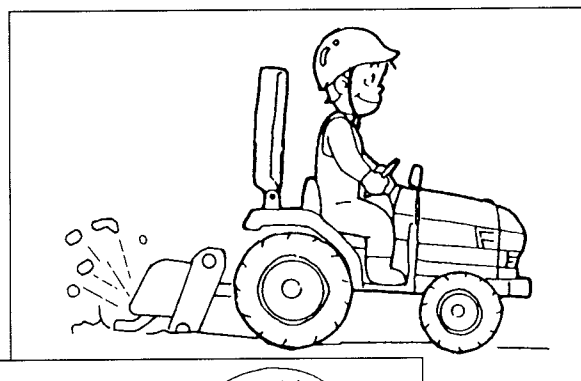

## **TM215F, TM217F & TM223F**

- (6) When moving the machine toward an implement for the purpose of installing the implement, never allow any one to stand in between. When installing the implement on the machine, be prepared to move away promptly in the event of an emergency. The brakes should be applied securely during installation.

### **■ INSPECTION AND MAINTENANCE**

- (1) When servicing the tractor or mounting or dismounting an implement, place the tractor on level, hard ground which is sufficiently illuminated, or unexpected accidents may occur.
- (2) When servicing the tractor, follow the instructions listed below:
- Apply parking brakes.
  - Disengage all PTO.
  - Place all gear shift levers in neutral.
  - Remove the starter key.
  - Lower the implement fully, if equipped. If not, your hands or clothes may be caught or sandwiched between.
- (3) When servicing the tractor, use proper tools. Using makeshift tools may lead to injuries or poor service, which may result in unexpected accidents during operation.
- (4) The engine, muffler, radiator, etc. are very hot just after operation, so wait until they cool down sufficiently to avoid burns.
- (5) Never remove the radiator cap while the engine is hot or running. Wait until the engine cools down and then relieve the radiator pressure by releasing the radiator cap. Carelessly pouring cooling water into the heated radiator can cause serious damage to the radiator and the engine. Careless removal of the radiator cap can cause serious injury because of overheated water vapour.
- (6) Never fit unauthorized implements or attempt unauthorized modification.

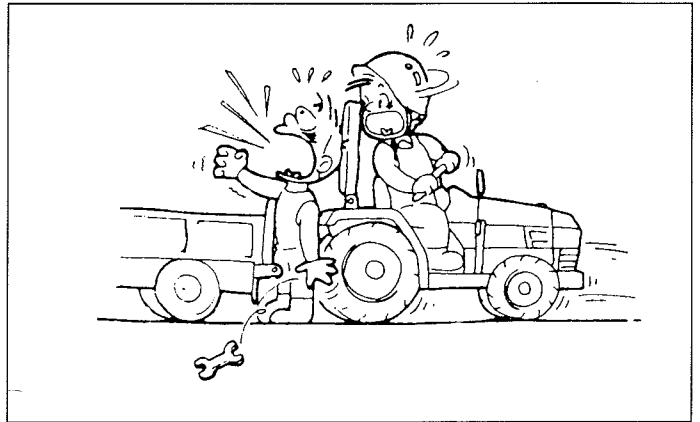

(7) Be sure to reinstall the removed safety covers in place as exposed dangerous parts may cause serious injury.

(8) Avoid high-pressure fluids. Escaping fluid under pressure can penetrate the skin and cause serious injury, so keep hands and body away from pin holes and nozzles ejecting such fluids. Be sure to consult your dealer about the hydraulic and fuel injection system trouble.

When checking for leaks, use a piece of cardboard or wood without fail.

If any hydraulic fluid is injected accidentally into the skin, it must be removed within a few hours by a doctor familiar with this type of injury.

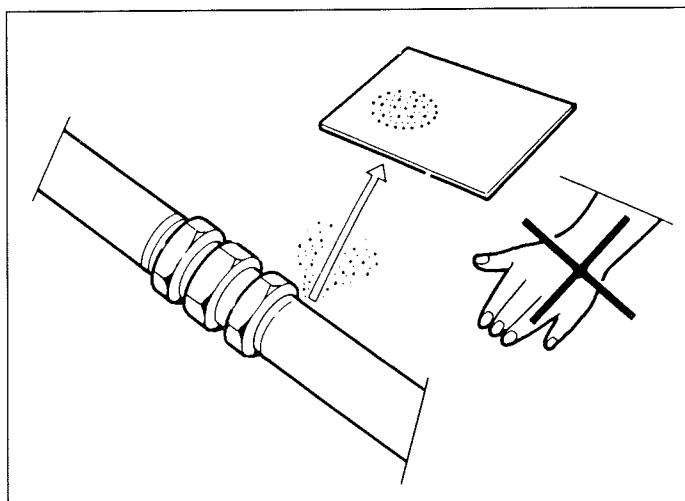

(9) When servicing wheels and tyres, the tractor and/or implement must be supported on suitable blocks or stands. Not a hydraulic jack.

Do not attempt to service a tyre unless you have the proper equipment and experience to perform the job. Have the work carried out by your ISEKI dealer or a qualified repair service.

When seating tyre beads onto rims, never exceed the maximum inflation specifications specified on the tyre. Inflation beyond this maximum pressure may brake the bead, or even the rim, with dangerous, explosive force.

If tyres have deep scratches, cuts or punctures, the respective tyre should be repaired or replaced by qualified personnel as soon as possible.

Wear suitable protective clothing, gloves, eye/face protection.

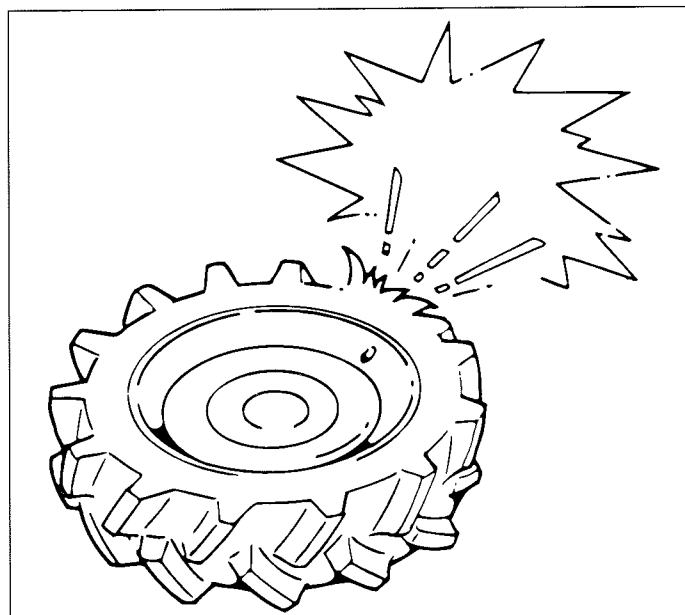

**■ STORAGE**

(1) Never cover a hot machine just after operation with a tarpaulin or the like, or the heated engine and related parts may cause a fire.

(2) Before storing the tractor for a long period of time, disconnect the battery cables to prevent them, in case they are gnawed by rats, from causing a short circuit, which may lead to a fire. When disconnecting the cables, disconnect the negative (-) cable first.

## **TM215F, TM217F & TM223F**

- (3) Safe storage of dangerous objects
  - When storing dangerous implements, take appropriate safety measures to prevent accidents by covering with tarpaulin.
  - Store fuel in a safe place with caution signs such as “PREVENT FIRE” or “INFLAMMABLE.”
  - All inflammables must also be stored in a safe, fire-resistant location.

### **MAINTENANCE OF THE ELECTRIC SYSTEM**

#### **■ TO MAINTAIN ELECTRIC WIRING**

- (1) When servicing the electric wiring, stop the engine without fail. Otherwise your hands or clothes may be caught in or sandwiched between rotating parts.
- (2) Before manipulating electric parts, be sure to disconnect the earth battery cable (-), or you may get an electric shock or be injured by sparks.
- (3) Loose electric terminals or connectors may not only lower electrical performance but also cause short circuit or leakage of electricity, which may lead to a fire. Promptly repair or replace damaged wiring.
- (4) Remove chaff or dust from the battery, wiring, muffler, or engine. Otherwise it could result a fire.

#### **■ TO HANDLE THE BATTERY**

- (1) When working around the battery, avoid smoking. The battery generates explosive hydrogen and oxygen gases when it is being charged. Keep the battery away from sparks or open flames.
- (2) The battery should be inspected before starting the engine. Be careful not to touch the electrolyte when removing the vent plugs. If the battery electrolyte makes contact with the skin or clothing, wash it off immediately with water and then consult a doctor.

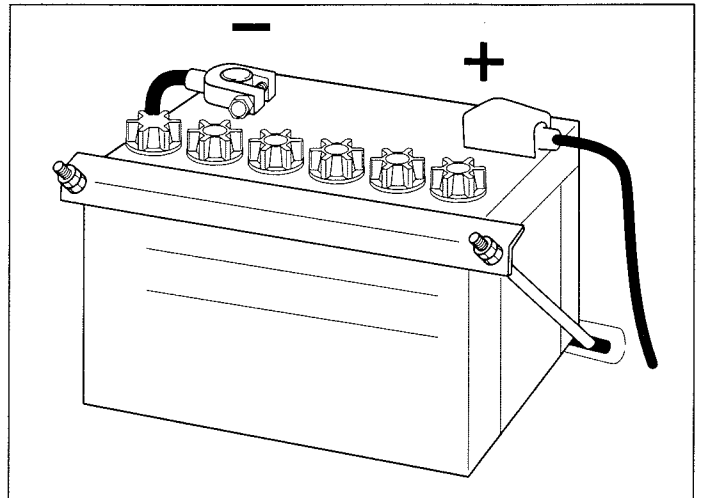

- (3) When replacing or inspecting the battery, stop the engine and turn the main switch off, or electrical parts may be damaged or unexpected accident may occur.
- (4) When disconnecting the battery cables, disconnect the earth cable (-) first without fail. When connecting the battery cables, connect the positive cable (+) first. Disconnecting or connecting in wrong order may lead to a short circuit or sparks.

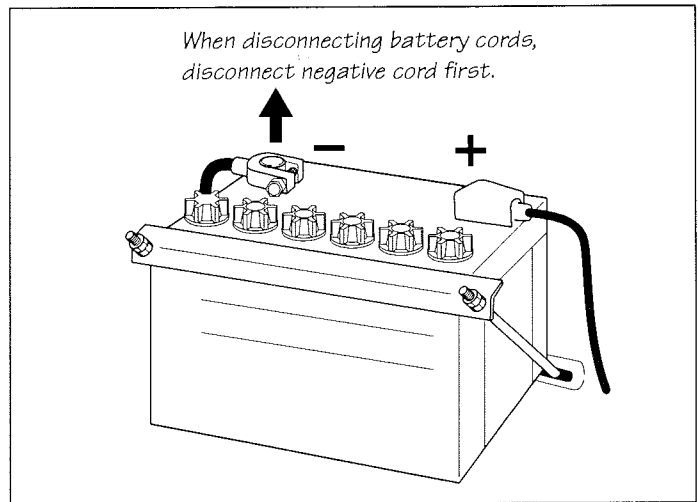

**■ TO HANDLE BOOSTER CABLES**

When using booster cables, pay attention to the following items for safe operation:

- (1) Before connecting cables, remove the vent plugs. This will lower the force in case of explosion.
- (2) Before connecting cables, be sure to stop the engine. Otherwise unexpected accidents may occur.
- (3) Use booster cables with sufficient electrical capacity. A cable of inadequate capacity will cause generation of heat, which may lead to a fire.

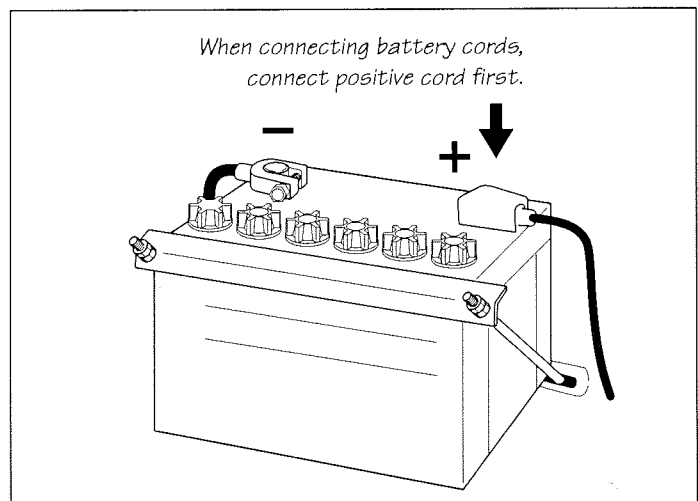

**■ SAFETY DECALS**

The labels are stuck on the tractor. You should of course read the safety instructions in the manual. But never fail to read the labels on the machine as well.

- The labels should always be clearly seen, that is, nothing should obscure them.
- When they have become dirty, wash them with soapy water and wipe off with soft cloth.
- If any of them are torn or lost, order new labels from your dealer. Their codes are mentioned in "SAFETY DECALS AND THEIR LOCATION."
- A new label should be placed in the same place where the old one was located.
- When sticking on a new label, clean the place to enable the label to stick and squeeze out all air bubbles trapped under it.

|    | English (E40G)  | French (E40F)   | German (E40D)   |
|----|-----------------|-----------------|-----------------|
| 1  | 1640-904-006-00 | 1640-903-006-00 | 1640-903-026-00 |
| 2  | 1640-904-007-00 | 1640-903-007-00 | 1640-903-027-00 |
| 3  | 1640-904-008-00 | 1640-903-008-00 | 1640-903-028-00 |
| 4  | 1640-904-009-10 | 1640-903-009-00 | 1640-903-029-00 |
| 5  | 1640-904-011-00 | 1640-903-011-00 | 1640-903-031-00 |
| 6  | 1640-904-012-00 | 1640-903-012-00 | 1640-903-032-00 |
| 7  | 1640-904-013-00 | 1640-903-013-00 | 1640-903-033-00 |
| 8  | 1640-904-016-00 | 1640-903-016-00 | 1640-903-036-00 |
| 9  | 1640-904-019-00 | 1640-903-015-00 | 1640-903-035-00 |
| 10 | 1640-904-022-00 | 1640-904-023-00 | 1640-904-024-00 |
| 11 | 1427-941-016-00 | 1427-934-013-00 | 1600-902-023-00 |
| 12 | 1682-902-012-10 | 1682-902-012-10 | 1682-902-012-10 |
| 13 | 1683-902-005-00 | 1683-902-005-00 | 1683-902-005-00 |
| 14 |                 | 1640-903-019-10 | 1640-903-039-00 |
| 15 | 1640-903-045-00 | 1640-903-046-00 | 1640-903-047-00 |

# TM215F, TM217F & TM223

## SAFETY DECALS AND THEIR LOCATION

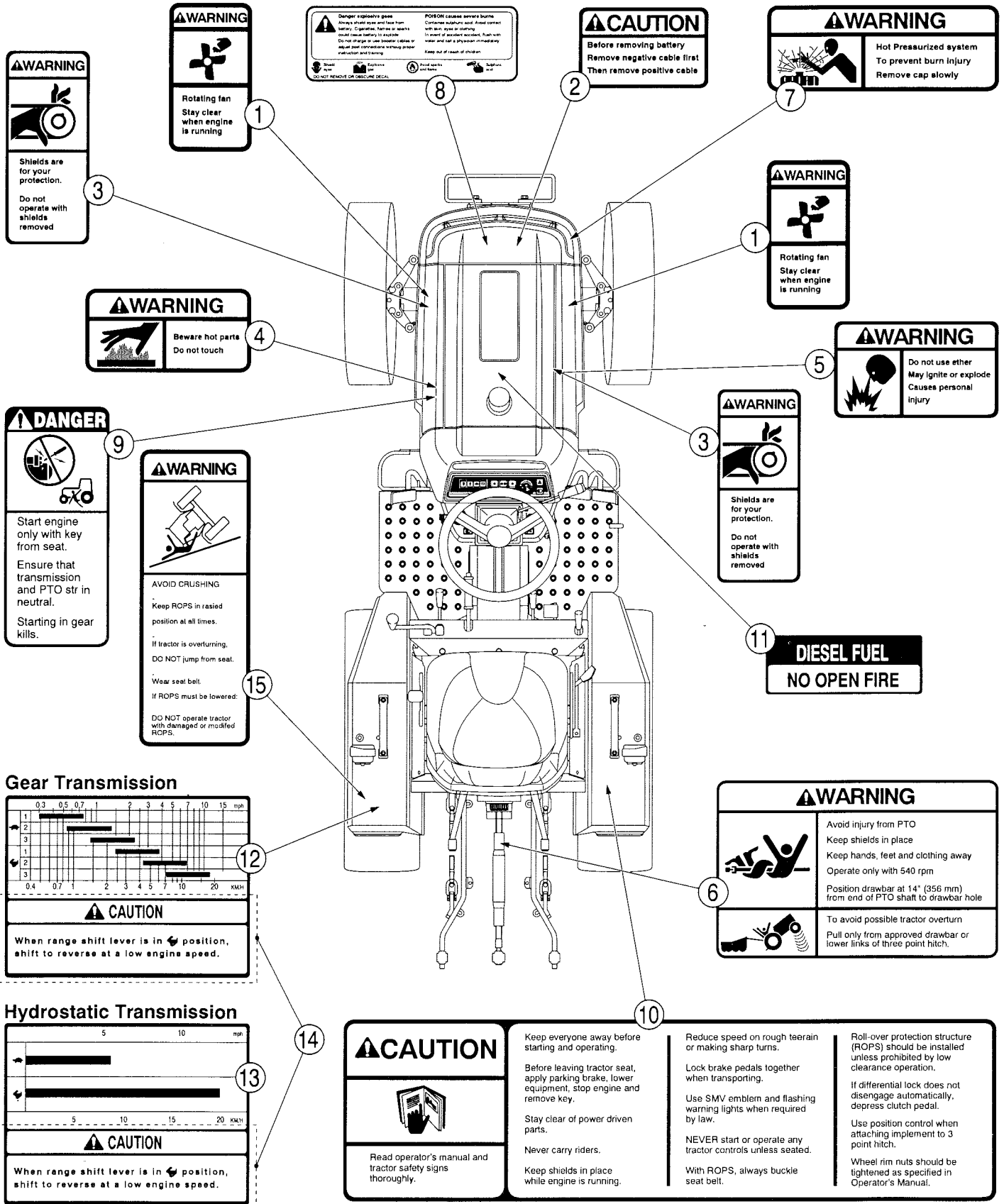

# TRACTOR IDENTIFICATION

**MODEL/SERIAL NUMBERS**



FIG. 1 (Name plate)

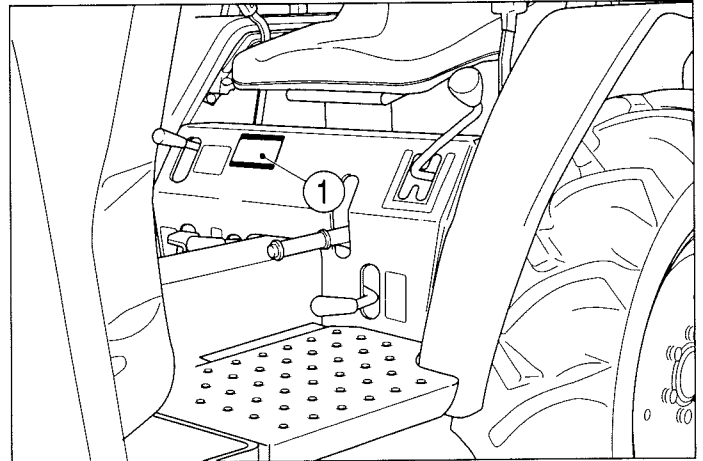

FIG. 2 (Location of name plate: Mechanical transmission)

Note the serial numbers of your tractor. Always quote the numbers in any communication to your ISEKI dealer.

TRACTOR SERIAL NUMBER (Fig. 1, 2 & 3)

ENGINE MODEL NUMBER (Fig. 4 (1))

ENGINE SERIAL NUMBER (Fig. 4 (2))

CHASSIS NUMBER (Fig. 5)

*NOTE: Reference to left-hand and right-hand, used throughout this book, refers to the position when seated in operator's seat and facing forward.*

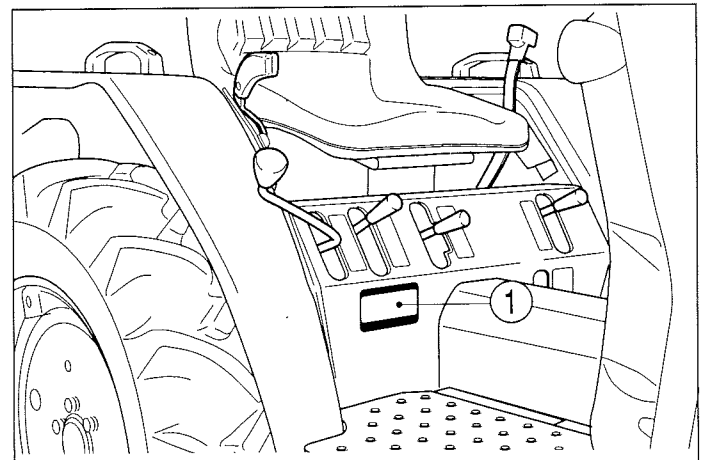

FIG. 3 (Location of name plate: HST transmission)

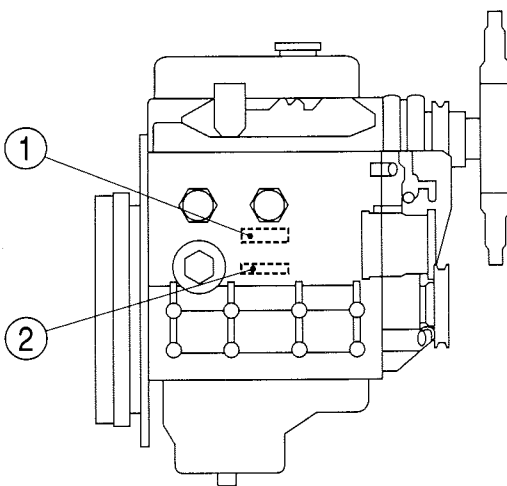

FIG. 4

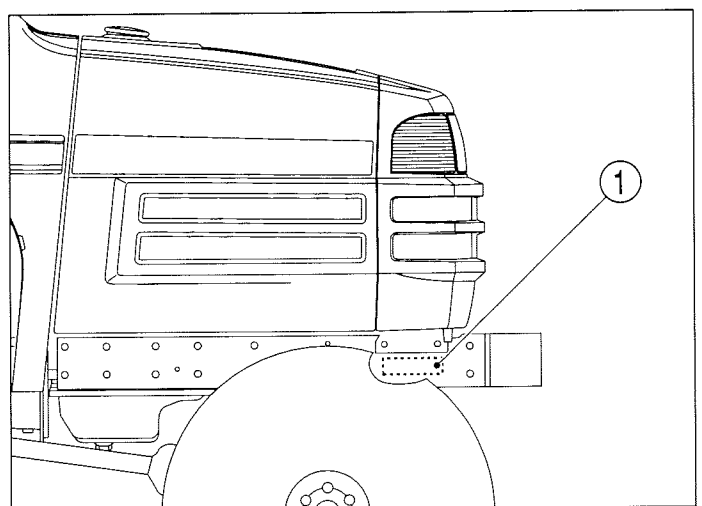

FIG. 5

# MAJOR COMPONENTS

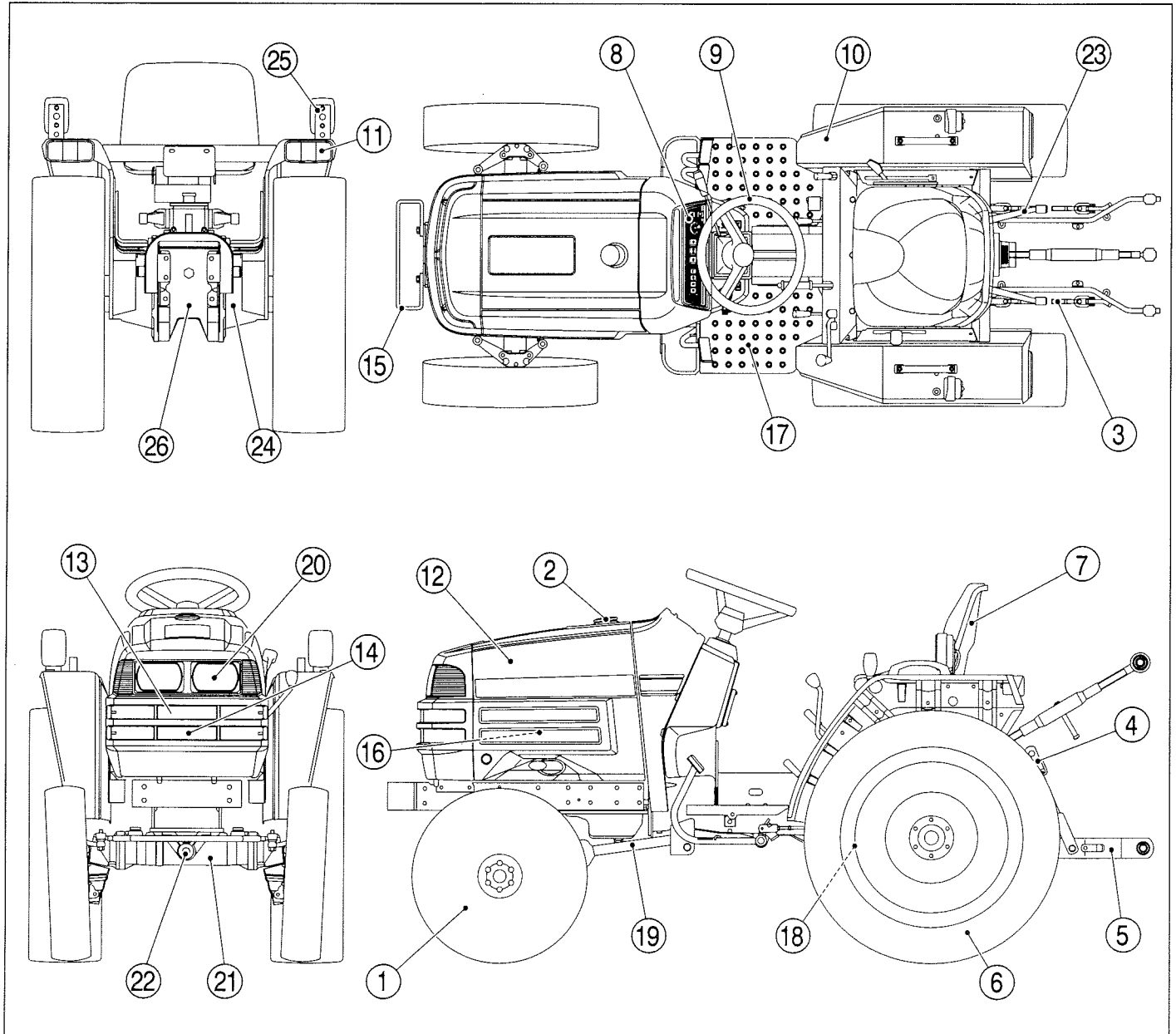

FIG. 6: Identification and terminology of major components, as given in this book, are as follows:

- |                     |                    |                             |
|---------------------|--------------------|-----------------------------|
| 1. Front Wheels     | 10. Fender         | 19. Front Wheel-Drive Shaft |
| 2. Fuel Tank Filler | 11. Rear Red Light | 20. Headlight               |
| 3. Check Chain      | 12. Hood           | 21. Front Axle              |
| 4. Lift Rod         | 13. Front Grille   | 22. Front Axle Pivot        |
| 5. Lower Link       | 14. Battery        | 23. Lift Arm                |
| 6. Rear Wheels      | 15. Front Bumper   | 24. Rear Axle               |
| 7. Operator's Seat  | 16. Engine         | 25. Turn Hazard Light       |
| 8. Instrument Panel | 17. Step           | 26. Centre Housing          |
| 9. Steering Wheel   | 18. Transmission   |                             |

# INSTRUMENTS & CONTROLS

Generally layout and location of controls within operator's area on Tractor. Specific use of these controls is given later in this section and also in "Operation" section of this book:

FIG. 7: Gear Transmission

1. Instrument Panel
2. Steering Wheel
3. Clutch Pedal
4. Parking Brake
5. Mid PTO Lever
6. 4WD Shift lever
7. Seat
8. Differential Lock Pedal
9. Main Gearshift Lever
10. Range Gearshift Lever
11. Rear PTO Lever
12. Three-Point Hitch Control
13. Foot Throttle
14. Throttle lever
15. Brake Pedals
16. Combination switch (horn button, headlamp switch, position lamp switch, turn signal switch)
17. Main beam (low/high) Switch
18. Main Switch
19. Hazard Signal Switch
20. Parking Lamp Switch

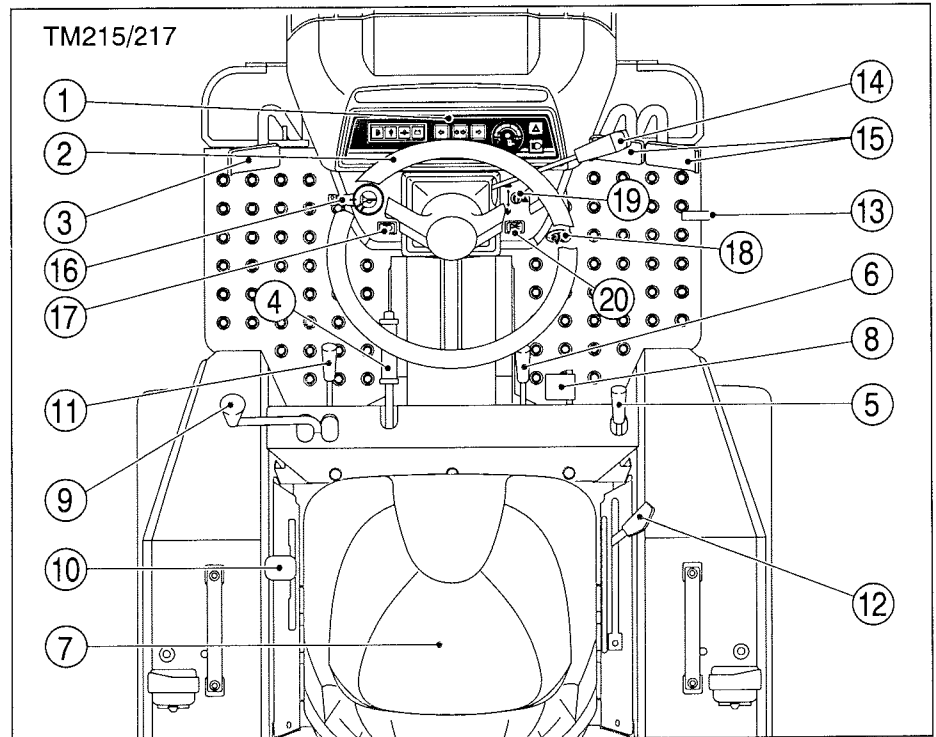
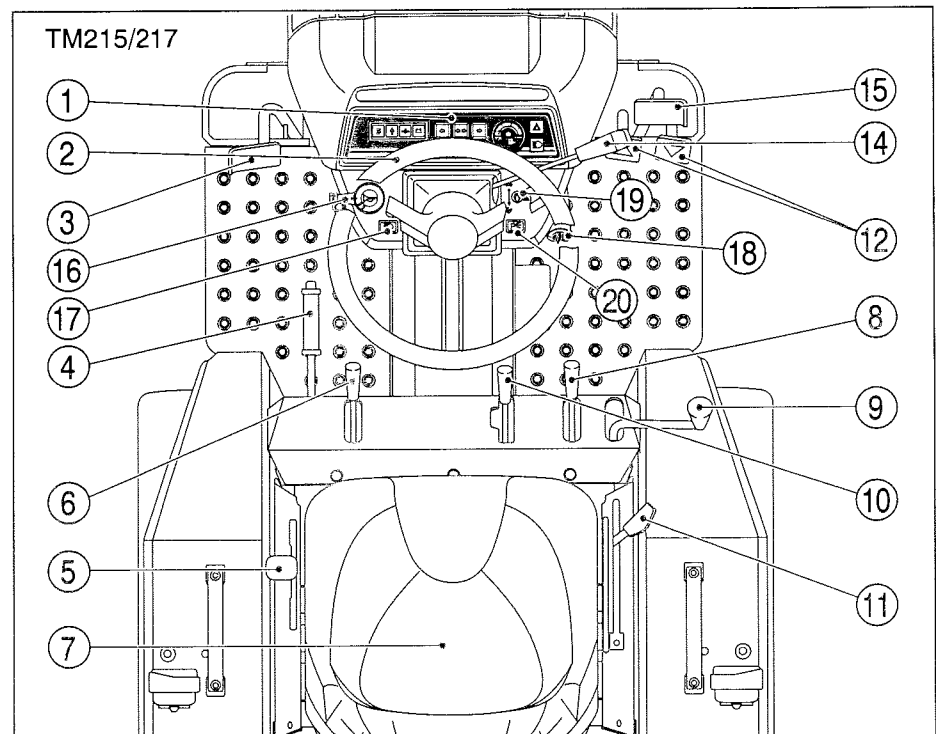

FIG. 8: Hydrostatic Transmission

1. Instrument Panel
2. Steering Wheel
3. Clutch Pedal
4. Parking Brake
5. Mid PTO Lever
6. 4WD Shift lever
7. Seat
8. Differential Lock Lever
9. Range Gearshift Lever
10. Rear PTO Lever
11. Three-Point Hitch Control Lever
12. Hydrostatic Foot Controls
14. Throttle lever
15. Brake Pedal
16. Combination switch (horn button, headlamp switch, position lamp switch, turn signal switch)
17. Main beam (low/high) Switch
18. Main Switch
19. Hazard Signal Switch
20. Parking Lamp Switch



**TM215F, TM217F & TM223F**

FIG. 9: Hydrostatic Transmission (TM223)

- 1. Instrument Panel
- 2. Steering Wheel
- 4. Parking Brake
- 5. Mid PTO Lever
- 6. 4WD Shift lever
- 7. Seat
- 8. Differential Lock Lever
- 9. Range Gearshift Lever
- 10. Rear PTO Lever
- 11. Three-Point Hitch Control Lever
- 12. Hydrostatic Foot Controls
- 14. Throttle lever
- 15. Brake Pedal
- 16. Combination switch (horn button, headlamp switch, position lamp switch, turn signal switch)
- 17. Main beam (low/high) Switch
- 18. Main Switch
- 19. Hazard Signal Switch
- 20. Parking Lamp Switch
- 21. PTO Switch

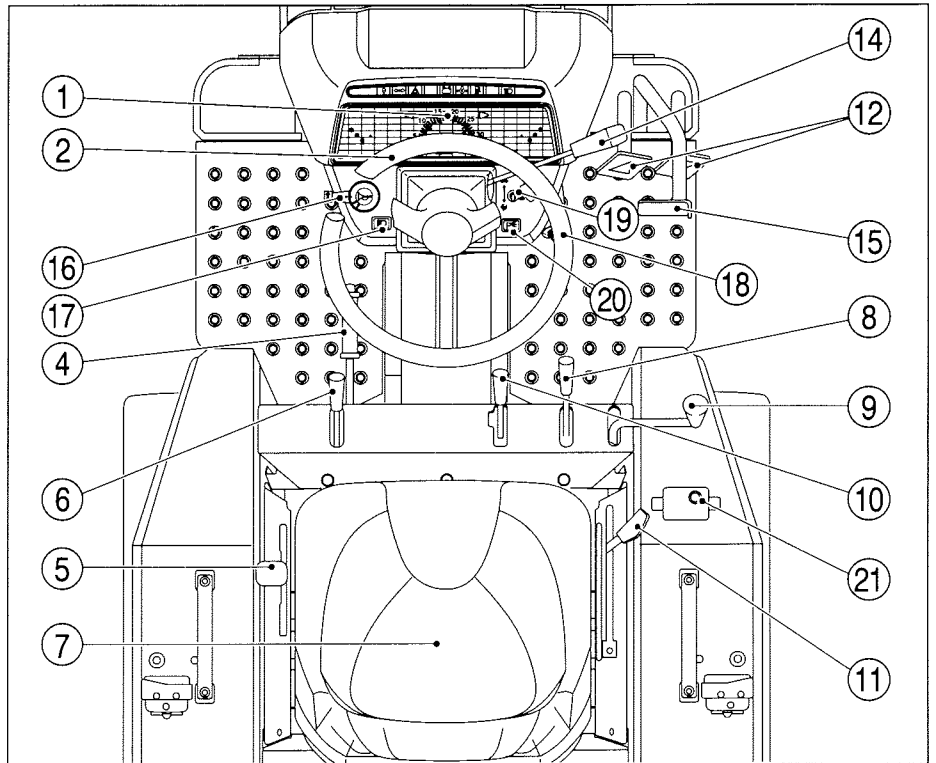

**INSTRUMENT PANEL**

FIG. 10/11: An arrangement of gauges, control switches and indicators located in instrument panel. Items are detailed in the description that follows:

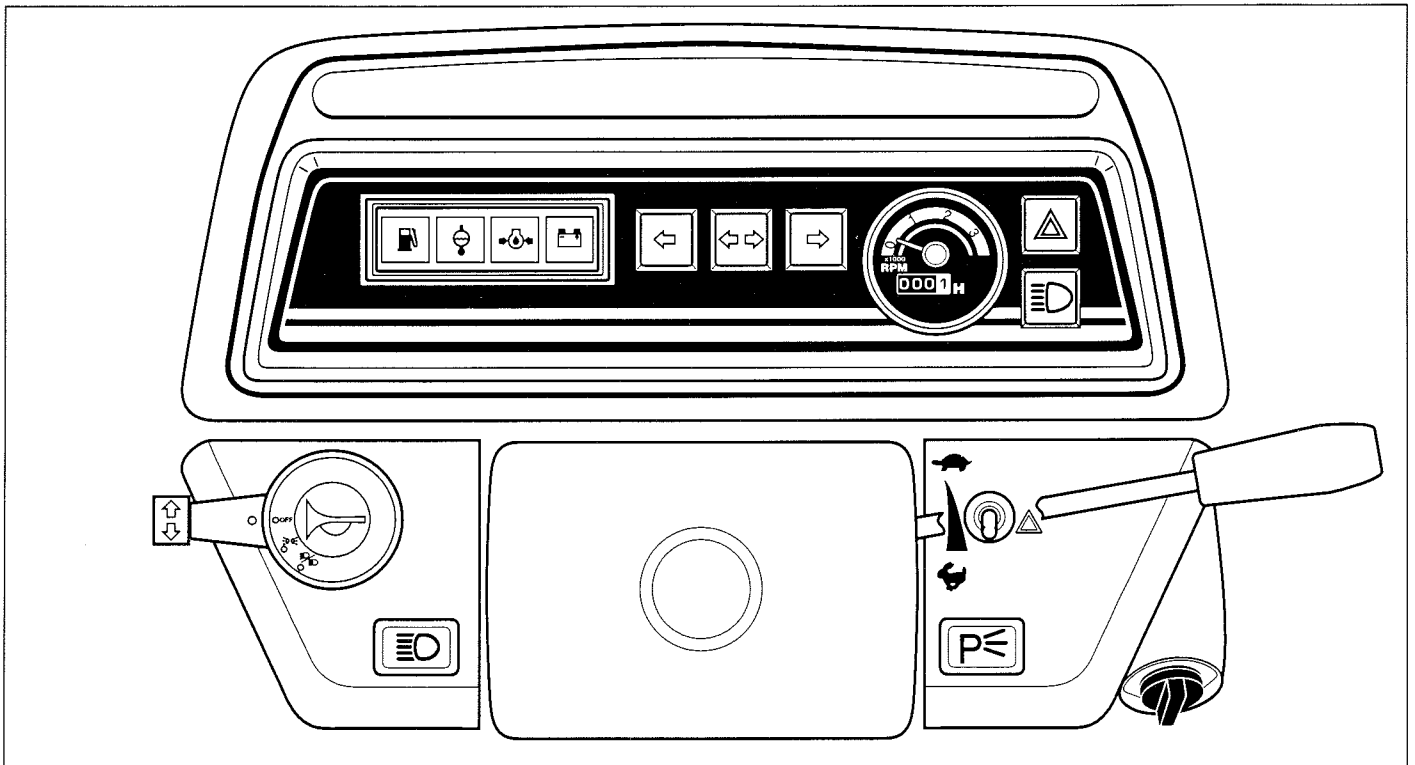

FIG. 10 (TM215/217)

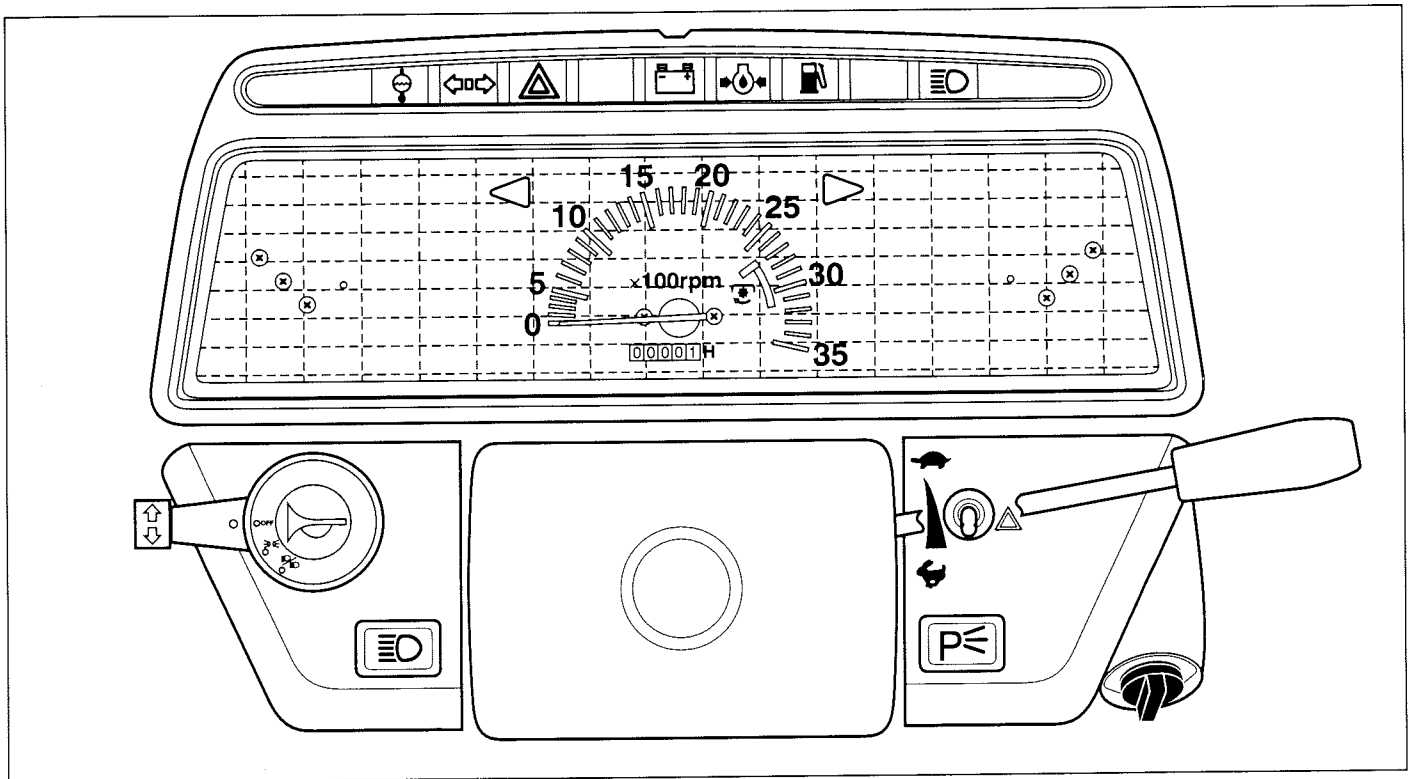

FIG. 11 (TM223)

**Electrical Fuel Shut-Off**

Turning the main switch to off will stop the engine.

- This tractor is equipped with a solenoid and a timer to shut the fuel off and the engine. When the main switch key is turned to off position, the timer activates the solenoid to shut the fuel off and hold it off for ten seconds, the solenoid then returns to “fuel on” position. The main switch key also overrides the timer to turn the fuel back on and allow the engine to be started immediately after being stopped.

**Main Switch**

FIG. 12: Main Switch (1) has the four following positions:

- **OFF** ..... Engine and all electrical circuits off. Key can be removed.
- **ON** ..... Power supplied to all circuits. Normal operating position.
- **START** ... Starter activated. This position spring-located to “ON”.
- **GLOW** ... (Turned to left) Energizes glow plugs to preheat the combustion chambers and assist starting. Spring-located to “OFF”.

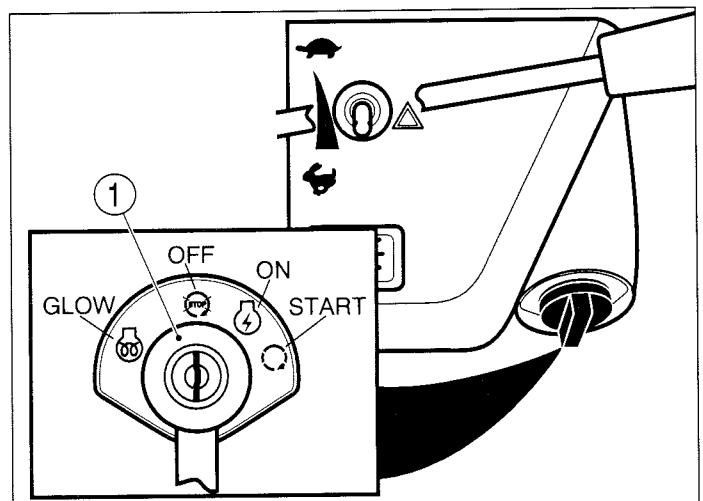

FIG. 12

## TM215F, TM217F & TM223F

**NOTE:** The main switch must be turned to “ON” before any circuits will operate. The PTO lever (or switch) must be off and the clutch pedal depressed (TM215/217) before the engine can be started.

**NOTE:** When the main switch is selected to “GLOW” position, the engine combustion chambers will be preheated and allow a cold engine to be started after several seconds.

### Indicator Light Strip

FIG. 13/14: Indicator light strip contains several warning lights to monitor certain functions. Currently used positions (from left to right) are:

- (1) **Fuel** - Illustrates when fuel tank level is lower than limit.
- (2) **Coolant Temperature** - Lights up when the engine is overheated.
- (3) **Engine Oil Pressure** - Lights up if engine oil pressure is low. If the light comes on while the engine is running, shut off the engine immediately and investigate the cause.
- (4) **Battery Charge** - Lights up when main switch is turned “ON” and will go out after engine starts, to indicate battery is being charged.
- (5) **Turn/Hazard Indicator Lamps** - Blinks when the turn signal is activated.
- (6) **Hazard Lamp** - Blinks when the hazard lamp switch is turned on. Both hazard lamps and turn signal lamps blink.
- (7) **Main (high) beam** - Lights up when the headlamps in the front grill are selected to the high beam position by the lamp switch.



**CAUTION:** Do not service hot engine. Allow to completely cool before servicing or removing radiator cap

**NOTE:** Use only clean diesel fuel and clean area to prevent dirt/water into fuel tank when refilling. DO NOT run out of fuel as bleeding air from the system will be required. Keep fuel tank full to minimize condensation.

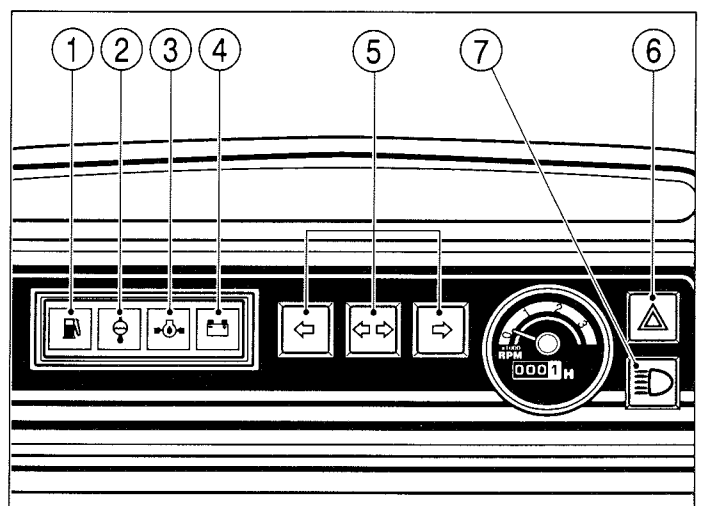

FIG. 13 (TM215/217)

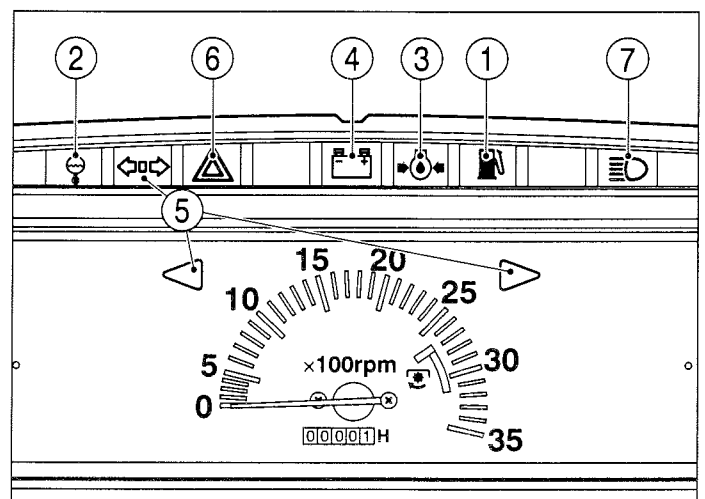

FIG. 14 (TM223)



**CAUTION: DO NOT** refill fuel tank with engine running or hot. Allow cooling period. **DO NOT** smoke near fuel tank and clean up any spilt fuel.

**Tachometer**

FIG. 15: Scale on gauge (1) indicates engine speed on crankshaft revolutions per minutes (rpm).

Hourmeter in centre of gauge indicates engine and tractor use to assist in maintenance intervals. The extreme right digit indicates 1/10 hour increments.

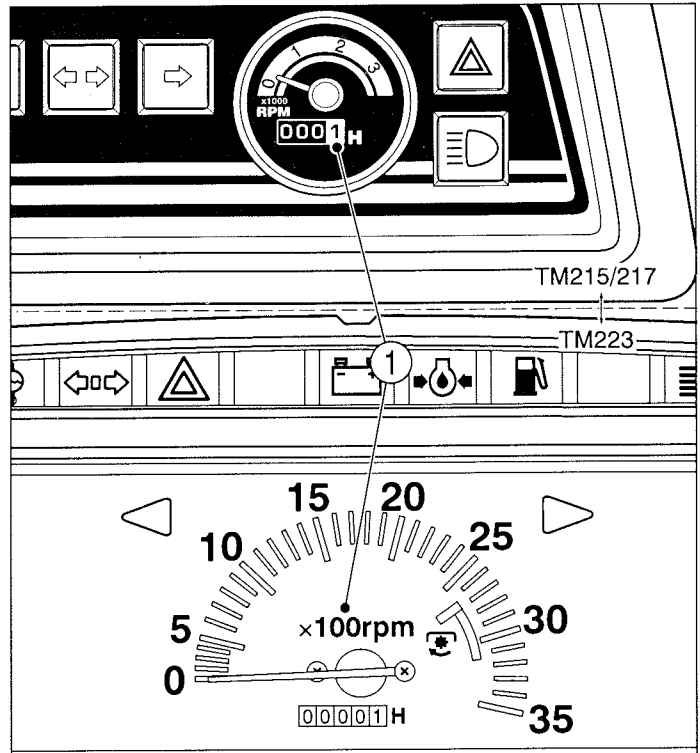

FIG. 15

**SWITCHES**

FIG. 16: Location of switches

**Combination switch (1)**

FIG. 17: This is a combination switch which incorporates the turn signal switch, headlamp switch, position lamp switch, and horn button. It works as illustrated.

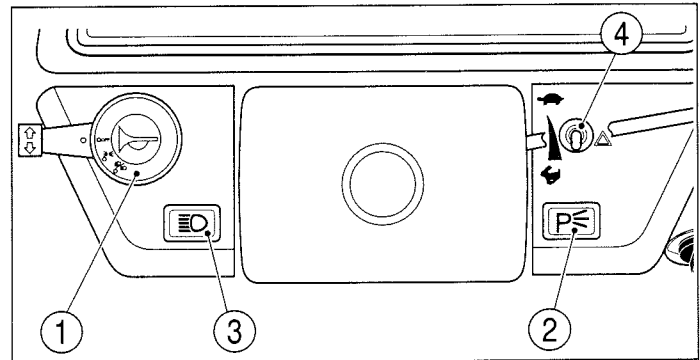

FIG. 16

The high or low beam is selected by setting the lamp switch.

- ..... Position lamps
- ..... Headlamps

**NOTE:** Turning indicator lamps will not self-cancel. Turn the turn/hazard lamp switch lever to the centre position after completing turn.

**Parking lamp switch (2)**

When pulled, position lamps light up.

**Main beam switch (3)**

The high or low beam is shifted over with this switch.

- ..... Low beam
- ..... High beam

**Hazard signal switch (4)**

When the switch is flipped on, all position lamps starts blinking.

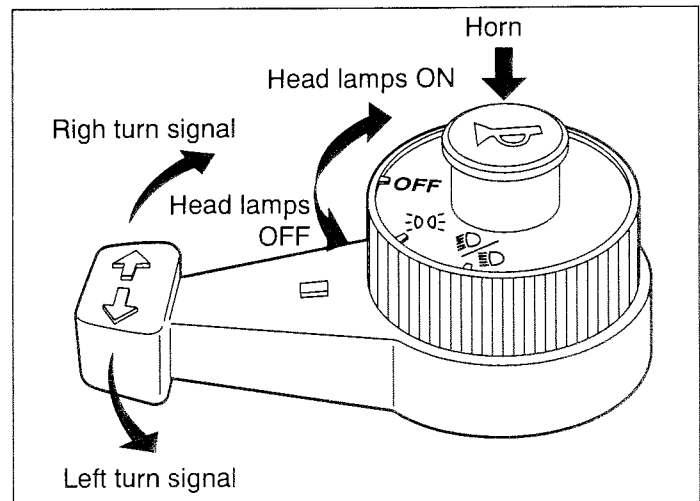

FIG. 17

## TM215F, TM217F & TM223F

### MAIN CLUTCH PEDAL (TM215/TM217)

FIG. 18: Foot pedal (1) disengages engine from transmission when fully depressed, to permit engine starting, selecting/changing gears and stopping Tractor movement. PTO and four-wheel drive selection (if equipped) also requires clutch disengagement. Slowly raising the pedal will engage clutch and resume power to transmission and PTO.

**NOTE:** Clutch pedal should be depressed quickly to prevent abnormal wear. Clutch pedal should be raised smoothly to prevent sudden movement. **DO NOT** "ride" clutch pedal with your foot.

**NOTE:** On Hydrostatic drive models of TM215 and TM217 the clutch pedal should only be used for starting, engaging PTO and emergency stopping of forward/reverse travel. It is not to be used to start forward or reverse travel.

**IMPORTANT:** Correct clutch pedal free-play adjustment is a must. Consult "Maintenance" section.

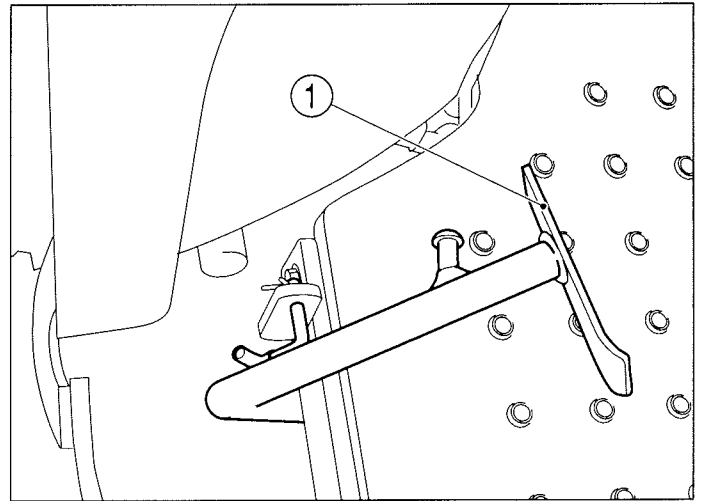

FIG. 18

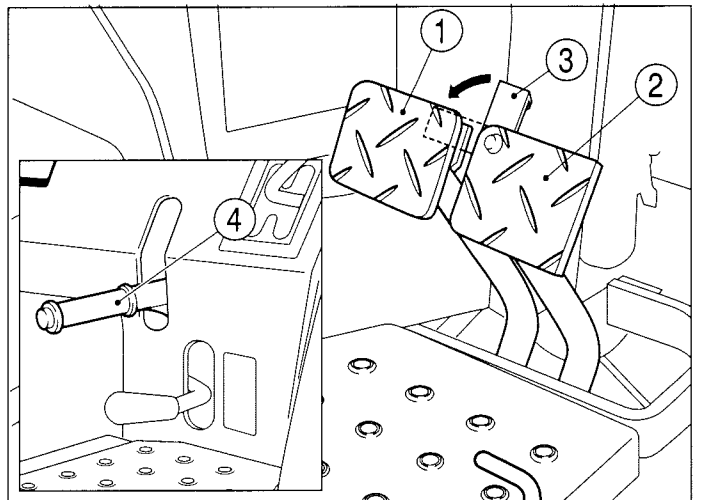

FIG.19 (Mechanical transmission)

## BRAKES

### Brake Pedals

FIG. 19 & 20: Inner brake pedal (1) and outer brake pedal (2) independently control the respective left and right wheel brakes, to assist in turning. During Tractor transport or high speed operation, brake pedals must be latched together using interlocking plate (3). Hydrostatic models do not have individual wheel brakes but single brake pedal (5).



**CAUTION:** Do not use individual wheel brakes for transporting or operating at high speed. Always latch pedals together using interlocking plate, 3. Make sure brakes are adjusted evenly.

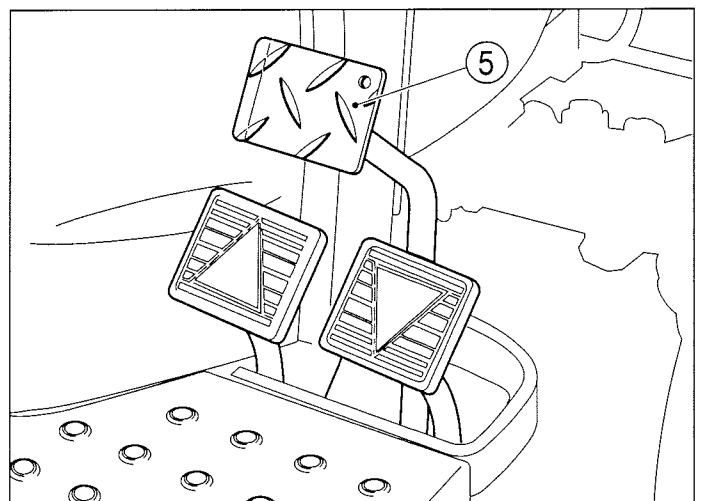

FIG. 20 (Hydrostatic transmission)

**Parking Brakes**

**Mechanical transmission**

FIG. 21: To engage parking brakes, pull upward on the parking lever (4) to lock brakes in applied position.

To disengage parking brakes, firmly depress both brake pedals to release the locking mechanism. Push in on release button (7) and lower the lever (4) to the released position.

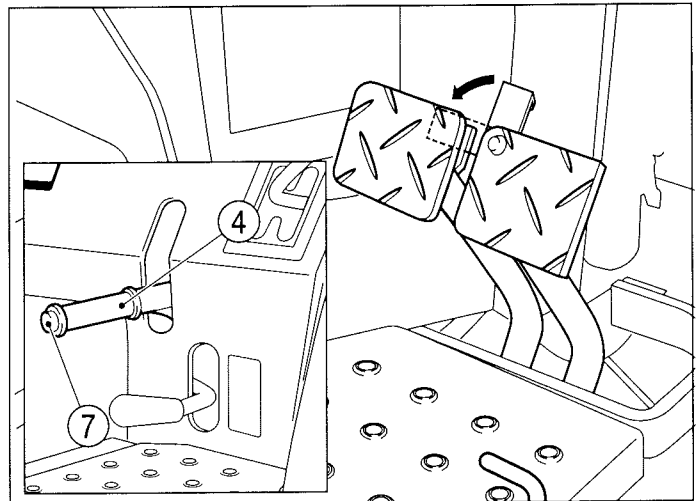

FIG. 21

**Hydrostatic transmission (HST)**

FIG. 22: To engage parking brakes, pull upward on the parking lever (6) to lock brakes in the applied position.

To disengage parking brakes, firmly depress the brake pedal to release locking mechanism. Push in on the release button (7) and lower lever (6) to the released position.

*IMPORTANT: Always disengage brake lever before driving Tractor to prevent abnormal brake wear.*

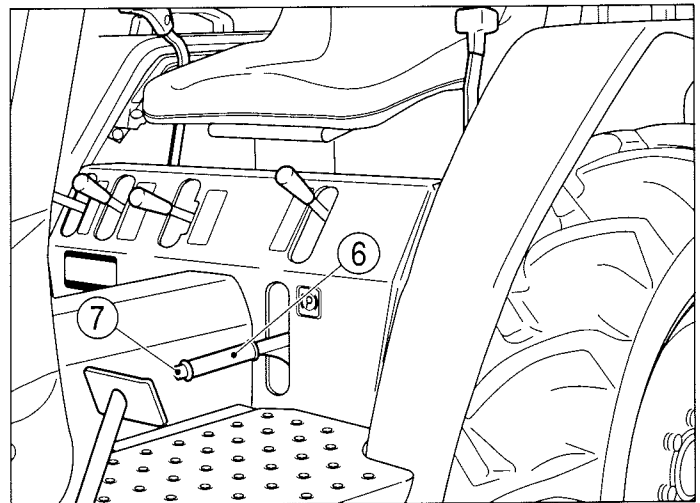

FIG. 22

**ENGINE SPEED CONTROLS**



*CAUTION: Always select engine speed to ensure safe operation. Reduce speed prior to turning or reversing tractor.*

*IMPORTANT: DO NOT “race” or excessively load cold engine.*

FIG. 23: **Throttle lever (1)** - Controls engine speed and will remain in position selected by the operator. With hand lever forward (➡), engine will idle. Engine speed increases as lever is pulled progressively rearward (←).

**Accelerator pedal (2)** - Will override setting of the throttle lever level for increased engine speed. When

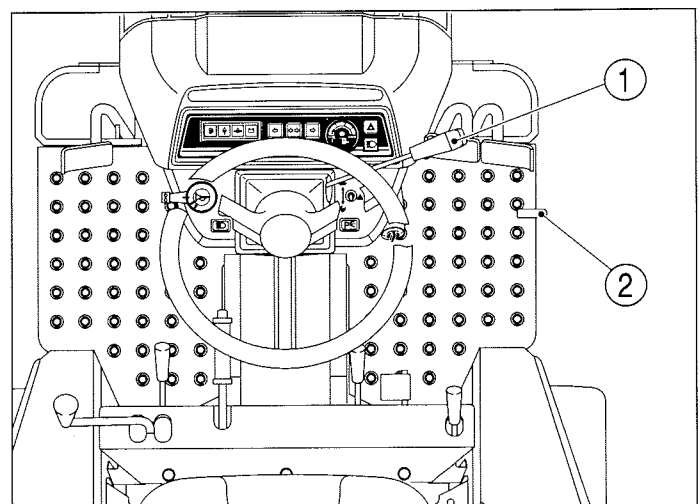

FIG. 23

## TM215F, TM217F & TM223F

the pedal is released, engine speed returns to the throttle lever level setting.

**NOTE:** *Hydrostatic models do not have an accelerator pedal.*



**CAUTION:** *When using the accelerator pedal, the throttle lever must be in the low idle speed position. This ensures maximum “engine braking” when the pedal is released.*

## TRAVEL CONTROL LEVERS

FIG. 24: Travel control levers

- A. **Gear transmissions**  
Main Shift Lever is located at front. It has three forward positions and one reverse as shown. Range Shift Lever is located at rear. It has tortoise and hare positions with neutral midway on quadrant.
- B. **Hydrostatic Transmissions (HST)**  
Range Shift Lever is located at right downside of the seat has tortoise, neutral, and hare positions as shown.

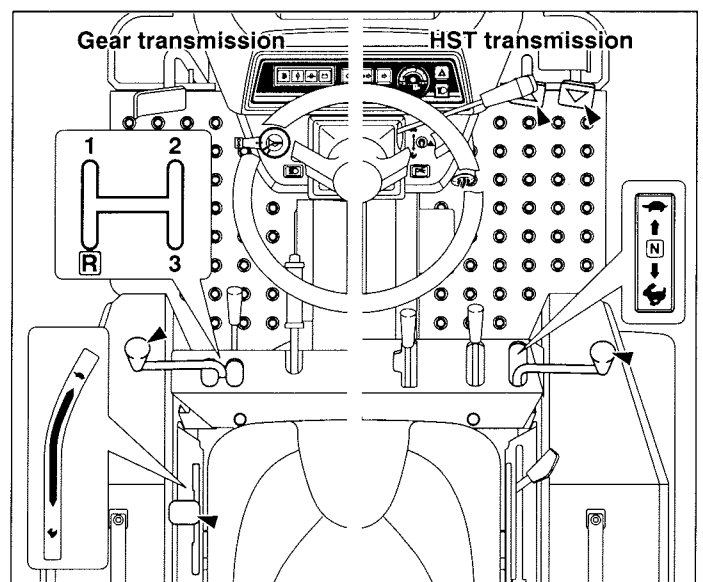

FIG. 24

## POWERTAKE-OFF (PTO) SWITCH (TM223)

FIG. 25: A toggle type safety switch (1) is used to engage and disengage the PTO drive system.

The switch must be pulled out and moved forward to engage the PTO.

The switch is moved to the rear to disengage the PTO.

**NOTE:** *FIG. 26: The PTO switch (Fig. 25) must be used in conjunction with the rear PTO selector control lever (1) or mid-PTO selector control lever (2), when a PTO is used. Refer to Operation Section of this book for complete details.*

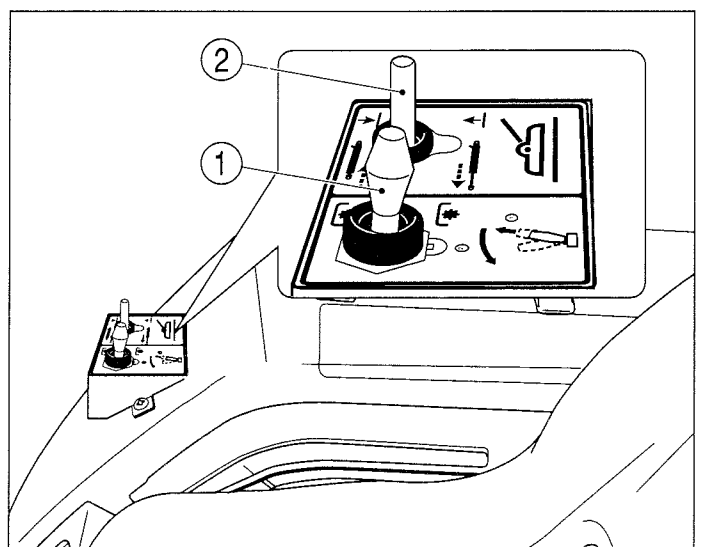

FIG. 25

When the PTO control switch is ON the engine cannot be started. Always switch the PTO switch OFF and both PTO control levers to OFF.

### REMOTE HYDRAULIC CYLINDER CONTROL SWITCH (OPTION)

FIG. 25: A toggle type switch (2) is used to activate the remote hydraulic cylinder: lifting up and down the mid-mount mower.

The switch must be flipped forward to lower and rearward to lift up the mower.

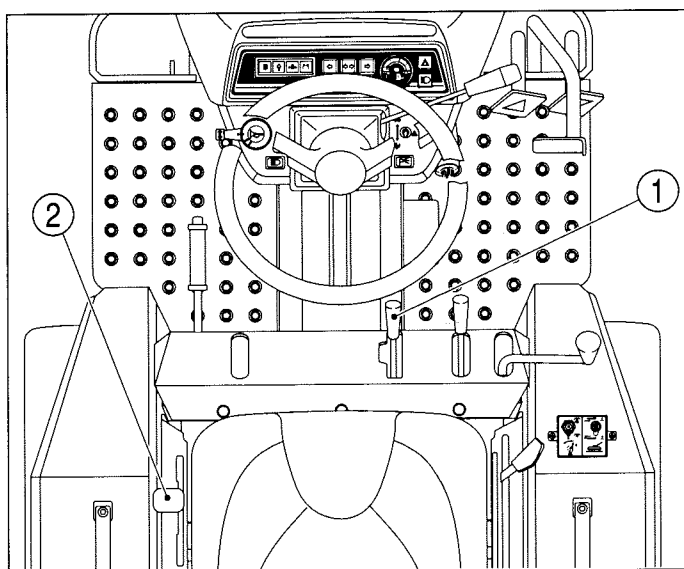

FIG. 26

### OTHER CONTROLS

Complete operating instructions for PTO and the three-points hitch controls are given in "Operation" section of this book.

## OPERATION

### BREAK-IN PERIOD

The operation of the tractor within the first fifty hours can be a major factor in determining the performance and life of the engine and the tractor:

- The engine may be operated at full rpm but excessive load should be avoided. If the engine begins to “lug,” operate in a lower gear to maintain higher engine speed.
- Check the coolant level and check the engine, transmission and other oil levels frequently during the break-in period. Watch for the evidence of leakage of above fluids. Replenish levels as required and repair any leaks that may have formed.
- Tighten any nuts, bolts, or screws that may have loosened and retighten as necessary. This is especially true of the wheel retaining bolts. All fasteners on this tractor are metric.
- Be observant of clutch pedal free-play adjustment and readjust as required (TM215/217). Lining materials used in the clutch disc and brake shoes “bed in” the first few hours of operation and may necessitate the need for early and frequent readjustment.
- Keep area around the fuel tank filler clean and make sure diesel fuel is of correct grade and free of contamination.
- Initial engine oil and oil filter change is after the first fifty hours of operation. Subsequent change interval are every one hundred fifty hours for engine oil and filter.



**CAUTION:** *Proper maintenance practices cannot be overemphasized. They are required of safe operation. Consult the “Lubrication and Maintenance” section for full details.*

### STARTING

#### Pre-Start Inspection

Prior to daily start-up of tractor, a few basic procedures should be followed to ensure tractor is in operating order to insure life and dependability:

- Make sure all safety shields are in place and secured properly.
- Ensure the operator is instructed in correct and safe operation of the tractor and related attachments or implements.
- Check coolant, engine oil and transmission oil levels and replenish as necessary.
- Check fan belt tension and adjust as require.
- Ensure the radiator, air intake screen and radiator screen are clear of debris to provide maximum engine cooling.
- Check operation of clutch (TM215/217), brake and throttle controls. All controls must operate freely and be adjusted correctly.
- General inspection of tyres, tyre pressure and wheel bolt torque. Observe for external signs of leakage and correct before operating the tractor. Check steering for excessive looseness.
- Check for adequate fuel supply. It is recommended the fuel tank be filled after the end of each day work to reduce condensation and provide full tank for next use.
- Check operation of lights and warning flashers. If the tractor is to be transported on public road, ensure a slow moving vehicle emblem is in place.

**NOTE:** *Requirements may vary regarding use of warning flashers and slow moving vehicle emblems depending on locality. Check local safety codes.*

**Normal Starting**



**CAUTION:** Do not attempt to start the tractor unless seated in the operator's seat. Do not allow anyone on the tractor except for the operator.

FIG. 27, 28, 29 & 30: To start the engine proceed as follows:

1. Apply parking brake (1).
2. (a) Gear transmission - Place range and gear-shift levers (2) in the neutral position.  
(b) Hydrostatic transmission - Place the range lever in neutral.
3. Make sure the rear PTO and mid PTO selector levers (3) are in the neutral position.
4. Fully depress the main clutch pedal (4) to disengage the clutch (TM215/217).

**NOTE:** Make sure the PTO switch (6) is in the OFF position (TM223).



**CAUTION:** The operator being seated in the operator's seat, the gearshift lever must be in neutral and the PTO levers must be in neutral to actuate safety switches and permit operation of the starter motor.

5. Set the position control lever (5) (three-point hitch) in the down position.
6. Turn the main switch (7) to the left to the "glow" position for 5-10 seconds until the indicator glows.
7. Set the throttle lever (8) at half to the fully open position.
8. Turn the main switch (7) to the "on" position for 1-2 seconds, then turn to the "start" position (9). Release the switch the moment engine starts.
9. Once the engine runs smoothly, set engine speed to approximately 1,500 rpm to allow the engine and hydraulic system to warm up for several minutes. **DO NOT LOAD A COLD ENGINE.**

**IMPORTANT:** Do not crank the engine for more than 10 seconds at a time. Allow the starter to cool at least 20 seconds before repeating procedure. Never turn the

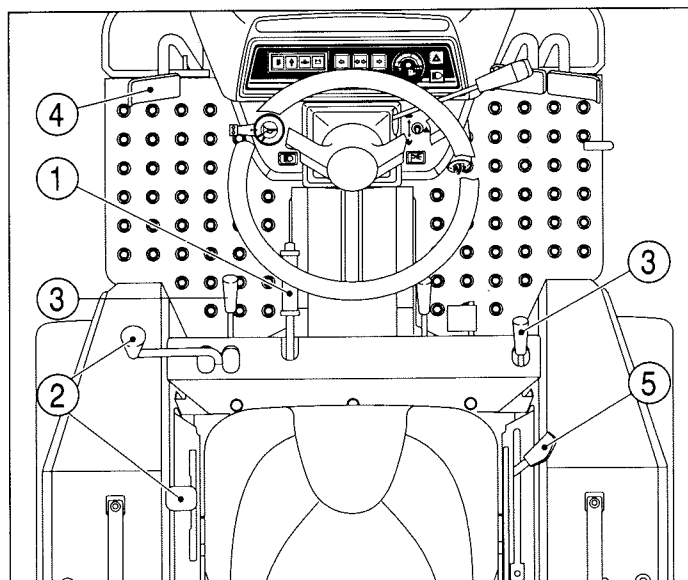

FIG. 27 (TM215/217, Mechanical Transmission)

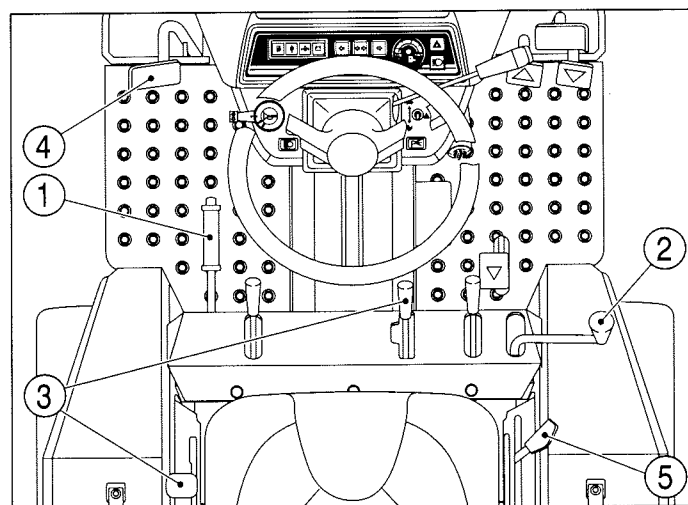

FIG. 28 (TM215/217, HST)

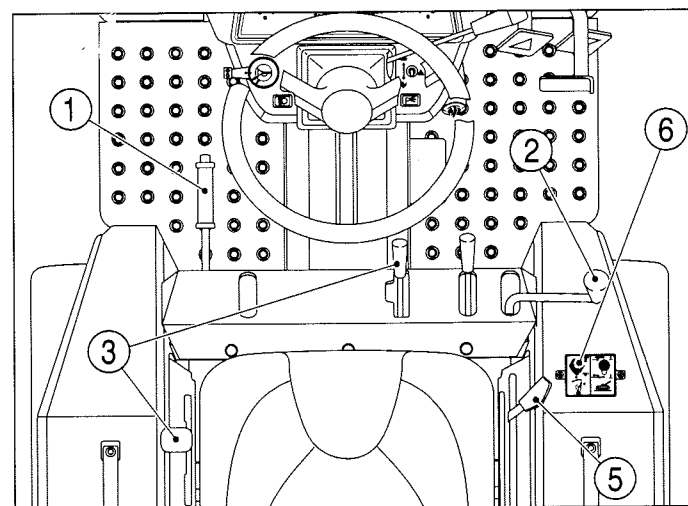

FIG. 29

## TM215F, TM217F & TM223F

*main switch to “start” with the engine running. Severe damage will result.*

FIG. 31 & 32: The battery charge indicator lamp and engine oil pressure lamp on the indicator light strip should go out when the engine starts. If either light remains lit, STOP THE ENGINE IMMEDIATELY and investigate source of problem.

**NOTE:** *If the engine will not start and run after several attempts, refer to “Maintenance” section in this book and bleed any air that may be present in the fuel system.*

### Restarting Warm Engine

When restarting an engine that is still warm from previous use, the same procedure is used as with “normal starting” except step No. 6 may be omitted. Use of glow plugs is not necessary when starting a warm engine.

### Cold Weather Starting

Procedure for starting an engine in cold ambient temperatures is identical to “Normal Starting” procedure except for the following:

1. Longer use of glow plugs may be required. Instead of the normal 5-10 seconds, the main switch may need to be selected to “glow” for 10-20 seconds to adequately warm engine combustion chambers.
2. At temperatures below 30° F (4° C) use of No. 1 (No. 1-D) diesel fuel is recommended due to possible “fuel gelling” characteristics of No. 2 (No. 2-D) fuel at cold ambient temperature.
3. The central hydraulic fluid in addition to transmission and centre housing lubrication, will require additional warm-up time due to cold (thicker) oil. Refer to “Warm-Up Period” at right.
4. Test all controls (steering, braking, etc.) prior to operating the tractor.

**NOTE:** *Installation of accessory engine block heater is recommended in cold weather conditions. Consult your ISEKI dealer.*

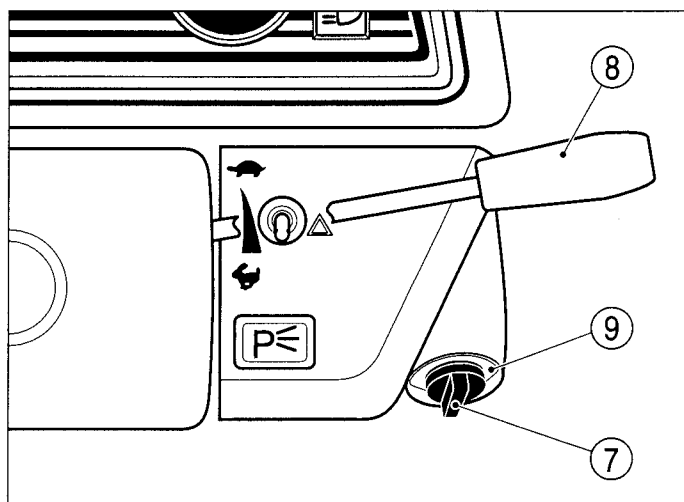

FIG. 30

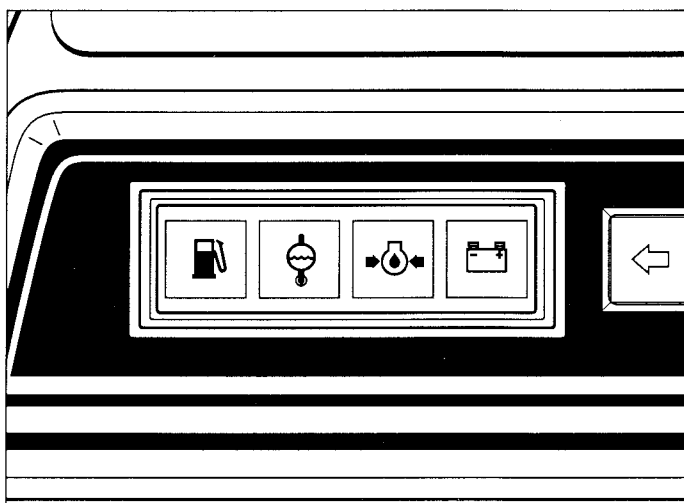

FIG. 31 (TM215/217)

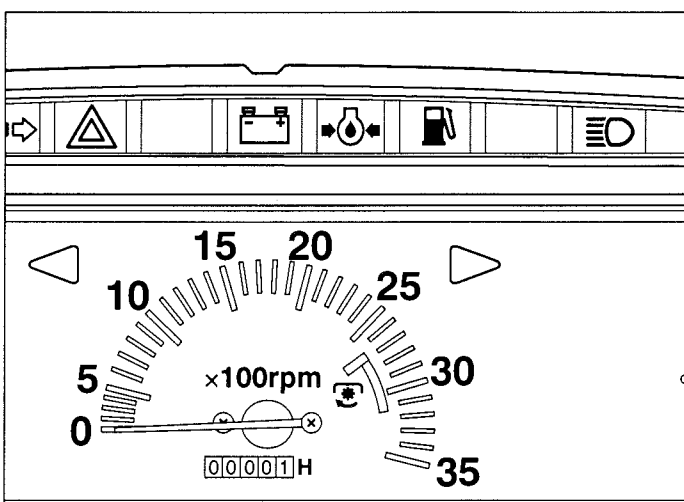

FIG. 32 (TM223)

**IMPORTANT:** *UNDER NO CIRCUMSTANCES SHOULD ETHER OR OTHER STARTING FLUID BE USED TO START ENGINES EQUIPPED WITH GLOW PLUGS. SEVERE ENGINE DAMAGE WILL RESULT SHOULD STARTING FLUID CONTACT A HOT GLOW PLUG.*

*If, for some reason, a booster battery be required to start the tractor, ensure a booster battery is connected in parallel. When using a booster battery and booster cables always connect positive (+) terminals together first. Then install booster cable on the booster battery negative (-) terminal and ground final booster cable end on the tractor away from the tractor battery.*

**Warm-Up Period**

After starting a cold engine, let the engine idle at slow speed to make sure all engine components are lubricated. In cold ambient temperatures, extended warm-up will be required to also warm hydraulic fluid and lubricate driveline components. Suggested warm-up period:

| Ambient Temp. |              | Warm-Up Time    |
|---------------|--------------|-----------------|
| F°            | C°           |                 |
| 32° & up      | 0° & up      | 5 to 10 min.    |
| 32° to 24°    | 0° to -10°   | 10 to 20 min.   |
| 24° to -2°    | -10° to -20° | 20 to 30 min.   |
| -2° & less    | -20° & less  | 30 min. or more |

**IMPORTANT:** *Improper warm-up can result in:*

- *Severe engine damage*
- *Hydraulic pump seizure*
- *Driveline bearing/gear damage*
- *Sluggish steering/braking*



**CAUTION:** *Make sure parking brake is securely applied and all controls are in neutral while warming unit. Do not leave unit unattended.*

**Operator Observations**

Constant attention should be paid to the following points during operation:

- Engine oil pressure lamp will come on in case of low engine oil pressure. Stop engine immediately.
- Battery charge lamp will come on if the battery is not being charged properly. Stop the engine and investigate the cause.
- Coolant temperature gauge needle will indicate H (hot) in case of an overheated engine. Stop the engine, and allow it to cool and investigate the cause of overheating.
- Fuel gauge should not be allowed to reach E (empty) as running out of fuel may result with need to bleed air from the fuel system.



**CAUTION:** *DO NOT attempted to service the tractor with the engine running or hot. Allow it to cool.*

**NOTE:** *Refer to “Trouble-Shooting” when defect is indicated, to assist locating problem.*

**MECHANICAL TRANSMISSION**

**Ground Speed Selection**

FIG. 25 & 26: TM215 and TM217 tractors are equipped to provide six forward gear speeds and two reverse gear speeds.

Gearshift lever (1) provides a three forward and one reverse gear selection. These gear selections provide small changes in ground speeds.

Range shift lever (2) provides major changes in ground speeds.

To start forward/reverse travel with the gear type transmission the tractor travel must be stopped. Depress the clutch pedal and position shift levers in desired positions. Release the parking brake and slowly release the clutch pedal. If another gear selection is required, stop travel and repeat the above operation.

FIG. 35: Arrangement of gears with appropriate ground speeds, in order from slow to fast, are shown in chart at right, for gear transmissions.

- NOTE:**
- Ground speed indicated for TM215 tractor at 2500 engine rpm with 8 × 16 agricultural-type rear tyres.
  - Ground speed indicated for TM217 tractor at 2500 engine rpm with 8 × 18 agricultural-type rear tyres.

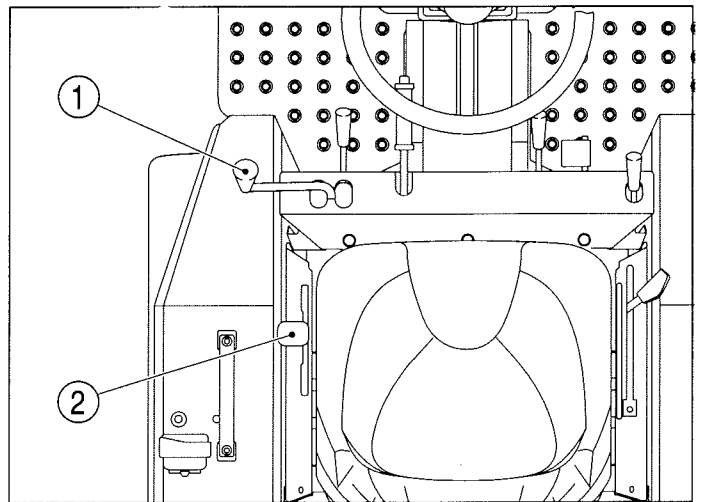

FIG. 33

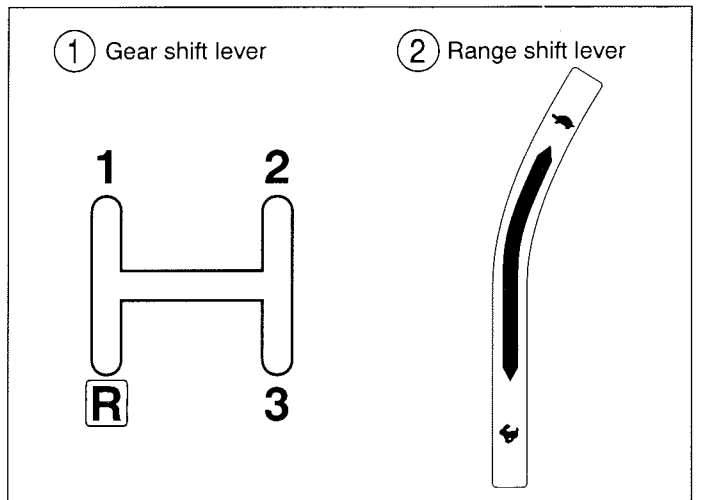

FIG. 34





| Shifting positions   |       | TM215F(AG) | TM217F(AG) | TM215F/217F(Turf) |
|--|-------|------------|------------|-------------------|
| Range  | Gear  | kph        | kph        | kph               |
| Forward  |       |            |            |                   |
|   | 1     | 1.17       | 1.24       | 1.12              |
|  | 2     | 2.11       | 2.25       | 2.03              |
|  | 3     | 3.48       | 3.7        | 3.33              |
|   | 1     | 5.86       | 6.23       | 5.62              |
|  | 2     | 10.6       | 11.3       | 10.1              |
|  | 3     | 17.4       | 18.5       | 16.7              |
|  | (Max) | 19.2       | 20.2       | 18.4              |
| Reverse  |       |            |            |                   |
| <br> | R     | 1.9        | 2.02       | 1.82              |
|  | R     | 9.51       | 10.1       | 9.12              |

FIG. 35

**Stopping Tractor**

FIG. 36: To stop the tractor with a regular gear transmission, move the throttle lever (1) forward, to reduce engine speed and slow travel. Depress the clutch pedal (2) and brake pedal (3) to stop. Position the range shift lever (4) and gearshift lever (5) in the neutral position. Latch the brake pedals together, depress the pedals firmly and set the parking brake (6). Allow the engine to idle several minutes to allow even cooling, then turn the main switch to the “off” position shutting off the engine. Lower the three-point hitch and remove the main switch key.

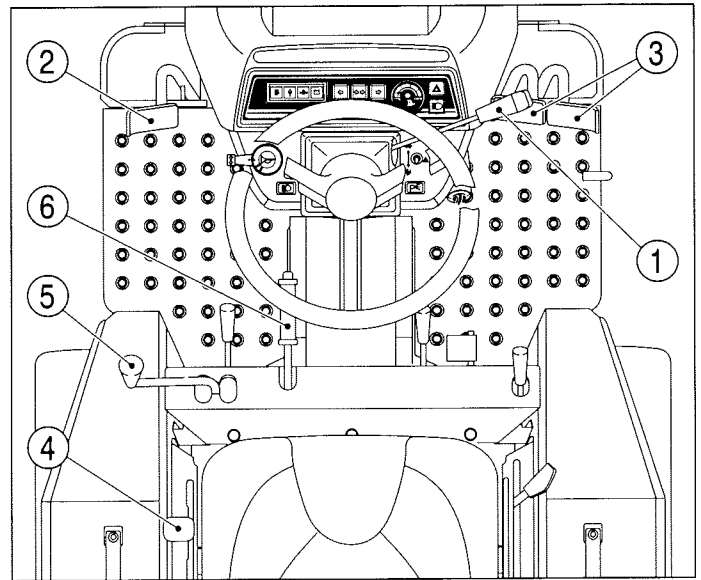

FIG. 36

**HYDROSTATIC TRANSMISSION**

**Ground Speed Selection**

FIG. 37 & 38: The Hydraulic transmission provides infinite speed control in forward or reverse.

The range shift lever (1) provides major changes in ground speed. Tractors have tortoise and hare speed selections.

Pedal (2) controls forward travel speed. As the pedal is progressively pushed down, a corresponding increase in ground speed will be noticed. When released, the pedal will return to neutral and the tractor stops travelling.

Reverse speed is obtained by pushing pedal (3) down. As the pedal is progressively pushed down, a corresponding increase in ground speed will be noticed. When released, the pedal will return to neutral and the tractor stops reversing.

*Important: Depress the clutch pedal (4) for TM215 and TM217 or release the HST control pedals (2 & 3) for TM223 and stop forward travel before changing range gears.*

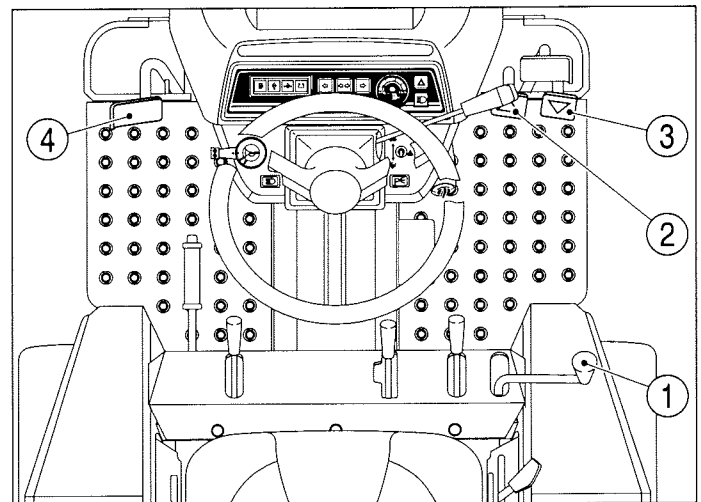

FIG. 37

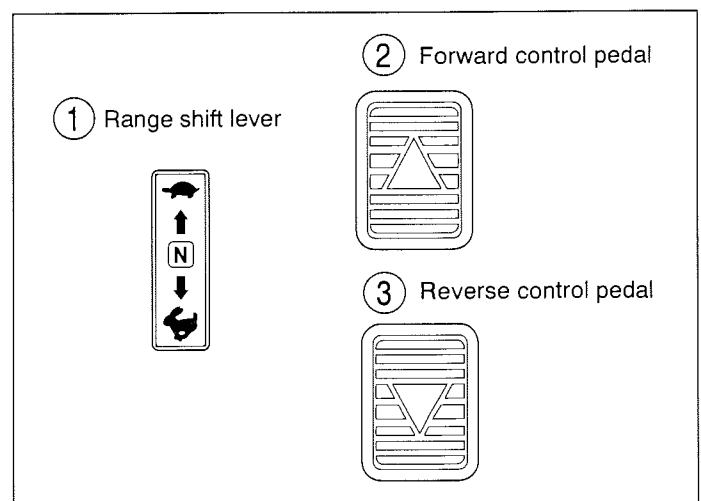

FIG. 38

## TM215F, TM217F & TM223F

FIG. 39: Arrangement of gears with appropriate ground speeds, in order from slow to fast, as shown in the chart at right, for hydrostatic transmission.

**NOTE:** • Ground speed indicated for TM215 tractor at 2500 engine rpm with 8 × 16 agricultural-type rear tyres.

• Ground speed indicated for TM217 tractor at 2500 engine rpm with 8 × 18 agricultural-type rear tyres.

• Ground speed indicated for TM223 tractor at 2,800 engine rpm with 9.5 × 16 agricultural-type rear tyres and at 2,800 engine rpm with 315 × 75D-15 turf-type tyres.

| Shifting positions |       | TM215F(AG) | TM217F(AG) | TM215F/217F(Turf) |
|--------------------|-------|------------|------------|-------------------|
| Range              | Gear  | km/h       | km/h       | km/h              |
| Forward            |       |            |            |                   |
|                    |       | 8.35       | 8.82       | 7.99              |
|                    |       | 19.5       | 20.6       | 18.6              |
|                    | (Max) | 21.5       | 22.7       | 20.5              |
| Reverse            |       |            |            |                   |
|                    |       | 5.9        | 6.23       | 5.64              |
|                    |       | 13.7       | 14.5       | 13.1              |

| Shifting positions |       | TM223F(AG) | TM223F(Turf) |
|--------------------|-------|------------|--------------|
| Range              | Gear  | km/h       | km/h         |
| Forward            |       |            |              |
|                    |       | 9.3        | 9.4          |
|                    |       | 21.6       | 21.8         |
|                    | (Max) | 23.6       | 23.8         |
| Reverse            |       |            |              |
|                    |       | 7.0        | 7.0          |
|                    |       | 16.2       | 16.4         |

FIG. 39



**CAUTION:** Before leaving the tractor unattended, make sure parking brakes are applied, rear mounted implement is lowered to the ground and the key is removed from the ignition switch.

## Stopping Tractor

FIG. 40: To stop the tractor with a hydrostatic transmission, release the forward HST pedal.

This action will stop forward travel. Move the throttle lever (1) forward to reduce engine speed, depress the brake pedals (2) and set the parking brake lever (3). Depress the clutch pedal (4) for TM215 and TM217 and move the range shift lever (5) to neutral position.

Allow the engine to idle several minutes to allow even cooling, then turn the main switch to the “off” position, shutting off the engine.

Lower the three-point hitch and remove the key from the main switch.

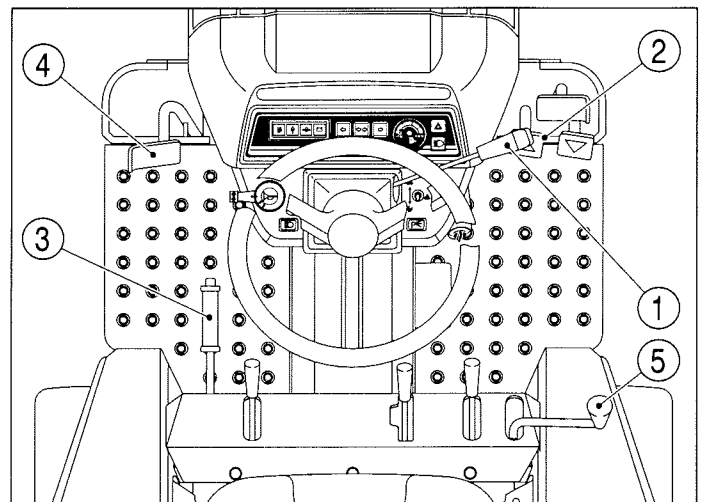

FIG. 40



**CAUTION:** Make sure brakes are adjusted evenly.

FIG. 41: Always park the tractor on level ground whenever possible. If hillside parking is necessary, securely block both rear wheels as shown.

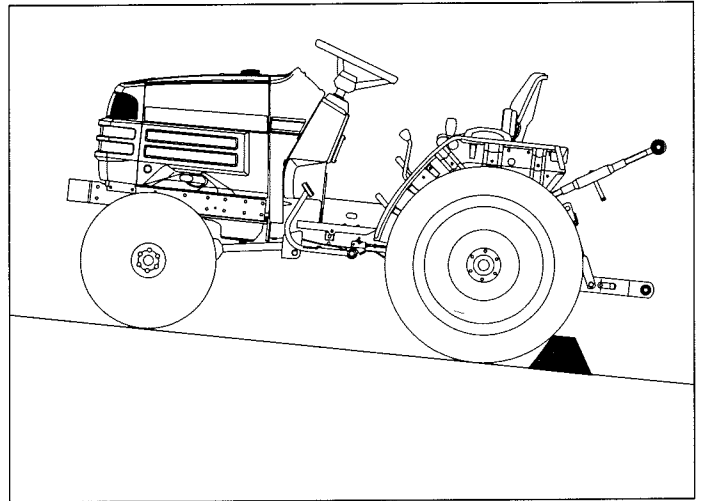

FIG. 41

**DIFFERENTIAL LOCK OPERATION**

**Mechanical Transmission**

FIG. 42: Differential lock pedal (1) should only be depressed when required as steering ability is greatly reduced. To engage the differential lock, depress the clutch pedal and allow all rear wheel movement to stop. Depress the lock pedal and slowly engage the clutch. To disengage the differential lock, depress the clutch pedal. The Differential Lock pedal should normally return to the “off” position.

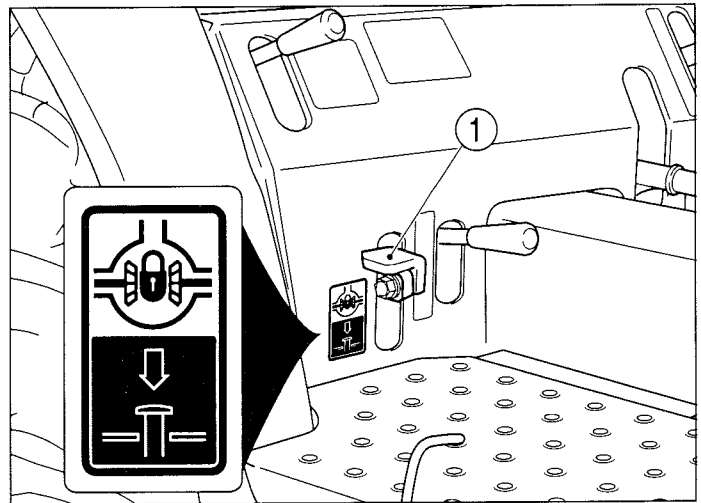

FIG. 42

**Hydrostatic Transmission**

FIG. 43: When the differential lock lever (2) is down, both rear axles are locked together to provide equal traction to both rear wheels. This is especially important when operating in loose soil or slippery conditions.

*NOTE: On occasion, the differential lock pedal may remain engaged due to torque difference exerted by rear wheels. In this case, tap brake pedals alternatively while the tractor is slowly in motion to release the pedal.*

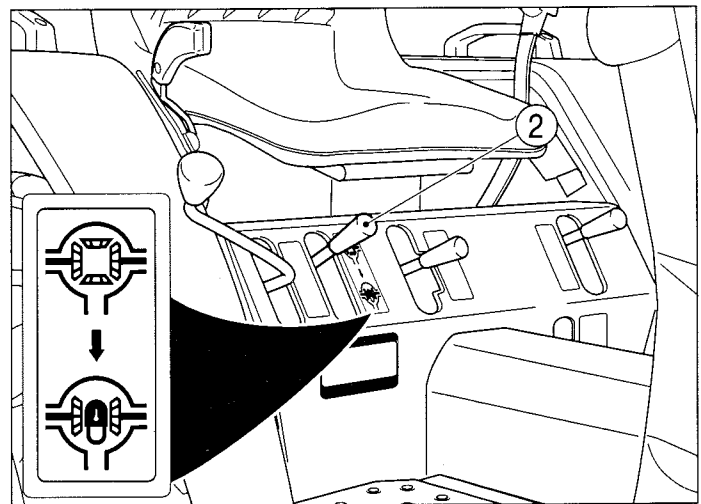

FIG. 43



**CAUTION: DO NOT use differential lock on hard surfaces while transporting the tractor. DO NOT engage with rear wheel(s) spinning as severe damage may result.**

## TM215F, TM217F & TM223F

**IMPORTANT:** Depress the main clutch pedal for TM215 and TM217 or release the HST control pedal for TM223 and stop the tractor before engaging the differential lock.



**CAUTION:** When the differential lock is engaged, steering ability of the tractor will be greatly reduced. Disengage before attempting a turn. Do not use during transport.

### FOUR-WHEEL DRIVE

FIG. 44 & 45: Four-wheel drive models have a mechanically driven front axle. Shift lever (1) engages and disengages drive for the axle. With the lever up, the front axle (4-WD) is disengaged. With the lever down, the front axle is engaged, and power is available to both front and rear axles.

**IMPORTANT:** Depress the main clutch pedal for TM215 and TM217 or release the HST control pedal for TM223 and stop the tractor before engaging or disengaging four-wheel drive. Do not use 4-WD on hard surfaces. Rapid wear of the front tyres and possible drive line damage could occur if 4-WD is operated for prolonged periods on hard surfaces.

FIG. 46: When the front axle drive is engaged, the ground speed of the front tyres will vary from that of rear tyres. This is to assist steering when four-wheel drive is selected. For this reason, the front axle must be disengaged when the tractor is transported or operated on a hard, dry surface. Failure to do so will result in rapid wear of the front drive tyres and possible driveline damage.

**IMPORTANT:** Always disengage front drive axle when operating in conditions with minimal wheel slippage (DRY OR HARD SURFACES). If tyre replacement is necessary, identical replace-

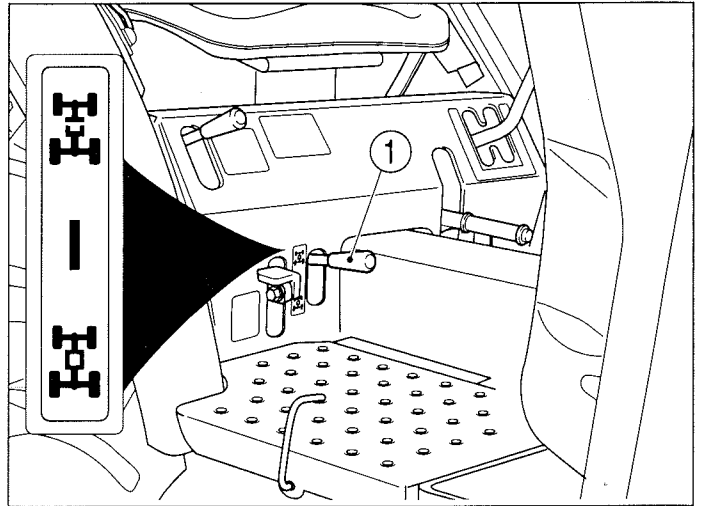

FIG. 44

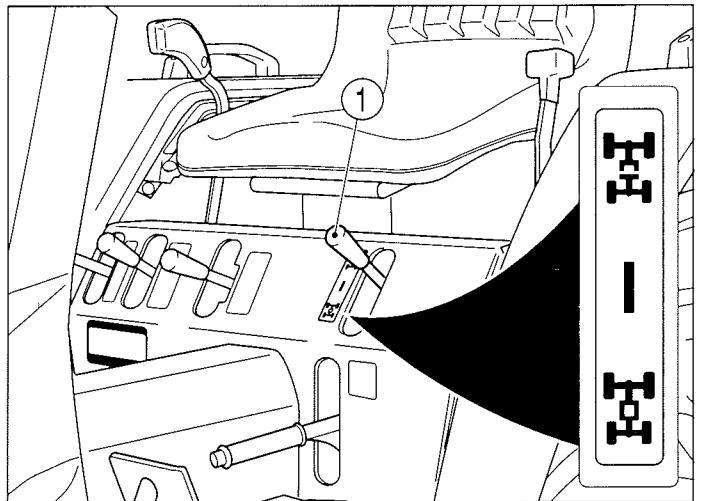

FIG. 45

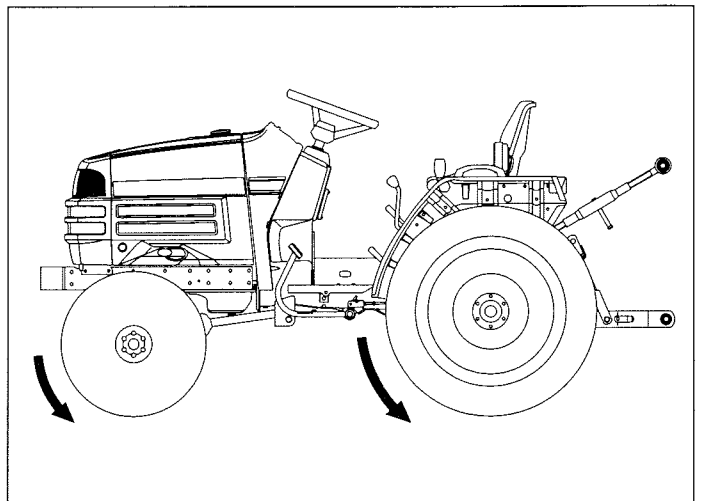

FIG. 46

ments must be installed to maintain correct front/rear axle ratio.

**POWER TAKE-OFF (PTO)**



**CAUTION:** Disengage the rear PTO selector lever, and shut off the engine prior to connecting equipment to or disconnecting it from the tractor's PTO shaft. Make certain the driver-shaft is securely locked in the annular groove of the tractor PTO shaft before starting the tractor engine.

**Rear PTO Shaft**

FIG. 47: A six-spline 1 3/8" (35 mm) PTO shaft (1) is provided at rear of the tractor to provide power for mounted and other PTO-driven equipment as required.

Normal rear PTO shaft operating speed:

Mechanical transmission ..... 540 rpm @ 2308 engine rpm

Hydrostatic transmission ..... 540 rpm @ 2398 engine rpm (TM215/217)  
540 rpm @ 2680 engine rpm (TM223)

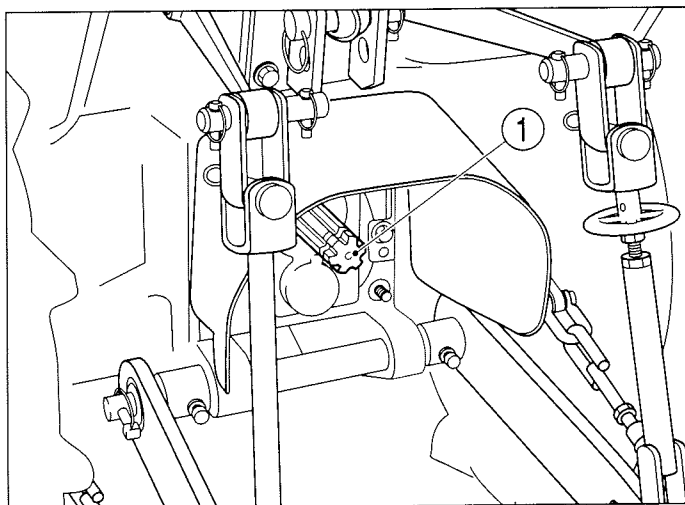

FIG. 47

A protective cover should be positioned over the shaft splines when not in use.

**IMPORTANT:** When the rear PTO is used with a three-point mounted equipment, it may be necessary to remove the drawbar, at rear of the tractor. Some types of mounted equipment, when lowered, may allow the PTO shaft to contact drawbar.

**TM215F, TM217F & TM223F**

FIG. 48: PTO shield cover



**CAUTION:** Make sure all PTO shields are installed on the tractor and equipment. Before cleaning or adjusting the tractor or PTO-driven machine, SHUT OFF THE ENGINE AND DISENGAGE THE PTO.

**Mid PTO Shaft**

FIG. 49 & 50: Mid PTO (1) is a forward-facing shaft located at underside of the tractor. This is installed to operate certain mid or front-mounted implements. A 1" (25.4 mm) fifteen-spline shaft is used.

Normal mid PTO shaft operating speed:

Mechanical transmission

..... 2000 rpm @ 2446 engine rpm

Hydrostatic transmission

..... 2000 rpm @ 2400 engine rpm  
(TM215/217)

..... 2000 rpm @ 2583 engine rpm  
(TM223)

The mid PTO cover must be installed when the use of the mid PTO is not required.



**CAUTION:** Make sure all PTO shields are installed on the tractor and equipment. Before cleaning or adjusting the tractor or any PTO driven machine, SHUT OFF THE ENGINE AND DISENGAGE THE PTO.

**PTO OPERATING CONTROLS**

**TM215 & TM217**

The rear PTO is engaged and disengaged using the lever. When the lever is at centre in notch, the rear PTO is disengaged. When the lever is at either end in slot, the rear PTO is engaged (540 rpm or 1000 rpm).

FIG. 51 & 52: Use the following procedures when operating with PTO tools, such as mowers, etc.

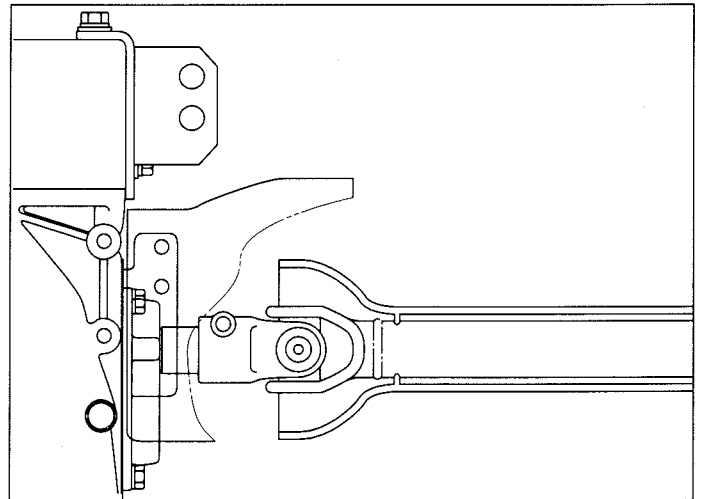

FIG. 48

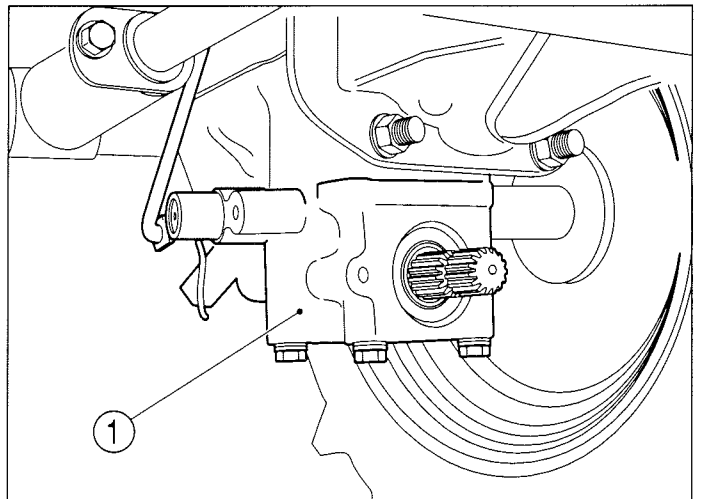

FIG. 49 (Mechanical transmission)

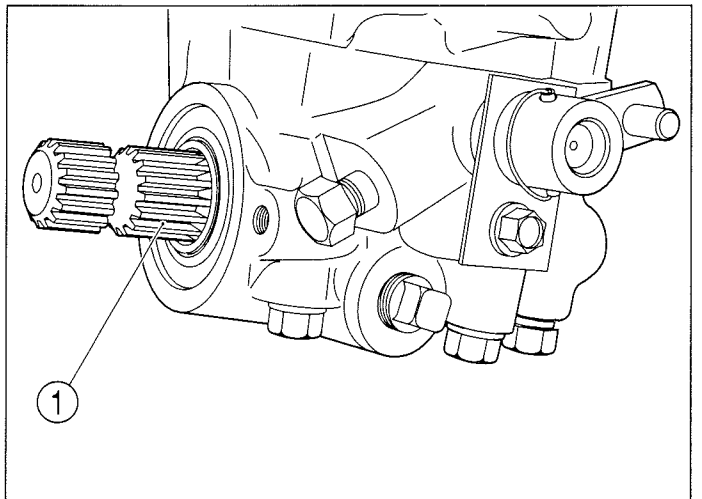



FIG. 50 (HST)



**Mechanical Transmission**

TM215 and TM217 tractors have a single clutch. With the PTO engaged and transmission gears selected, the PTO will start turning and the tractor will start moving forward as the clutch is released.

In operations such as mowing grass it will be necessary to back the tractor up about two tractor lengths away from uncut grass. This will allow time to start forward motion and obtain correct PTO speed prior to entering the area of uncut grass.



To select the rear PTO, push the clutch pedal completely down to disengage drives to the PTO and transmission. Lever (1) to  or  position in slot and the gearshift levers to selected gear. Release the clutch pedal at slow engine speed to start the PTO and forward travel, then increase engine speed to obtain the required PTO speed (540 rpm or 1000 rpm).

**Hydrostatic transmission**

TM215 and TM217 tractors have a single clutch. To select the rear PTO, push the clutch pedal completely down to disengage drive to the PTO drive train. Allow time for drive train to stop, and then move the lever (1) to  or  position in slot.

Make sure the range shift lever is in the selected gear.

To engage the PTO slowly, release the clutch pedal. Then increase engine speed to obtain the required PTO speed. With PTO running at the required speed and correct range gear selected, depress the hydrostatic control pedal to start forward travel.

FIG. 53 & 54: To select the mid mounted PTO, use the same procedure as outlined above, but use the mid PTO control lever. With the clutch pedal fully depressed move the lever (1) to  position to engage the PTO and to  position to disengage it.

**IMPORTANT:** Before moving the rear and mid-PTO selector levers, the clutch pedal must be depressed to disengage power to the drive.

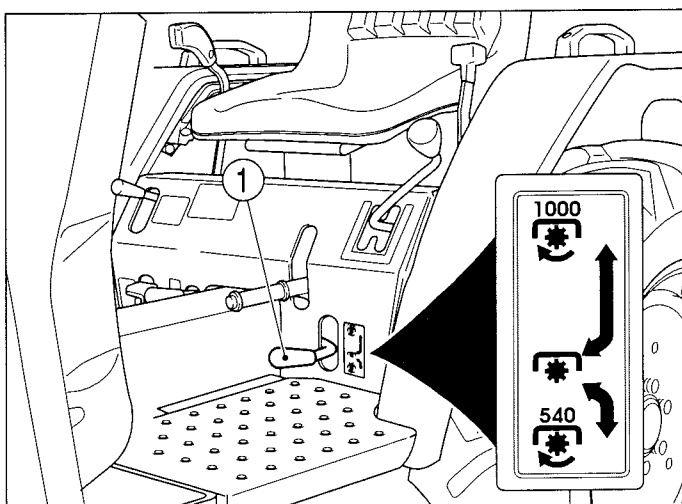

FIG. 51

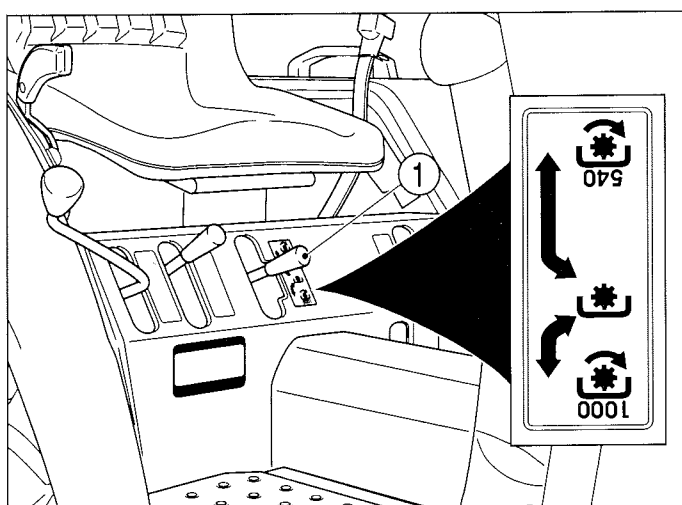

FIG. 52

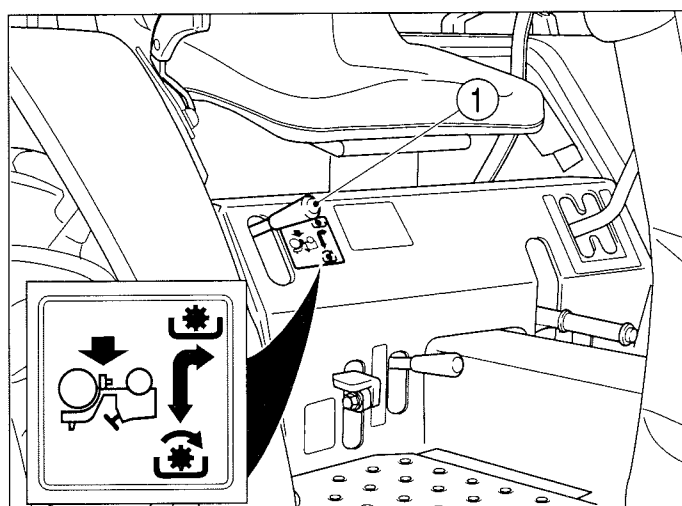

FIG. 53

**TM215F, TM217F & TM223F**

- NOTE:**
- The rear PTO selector lever has to be moved two times as a safety measure.
  - Determine the PTO engaging position on your tractor by checking the label on it.

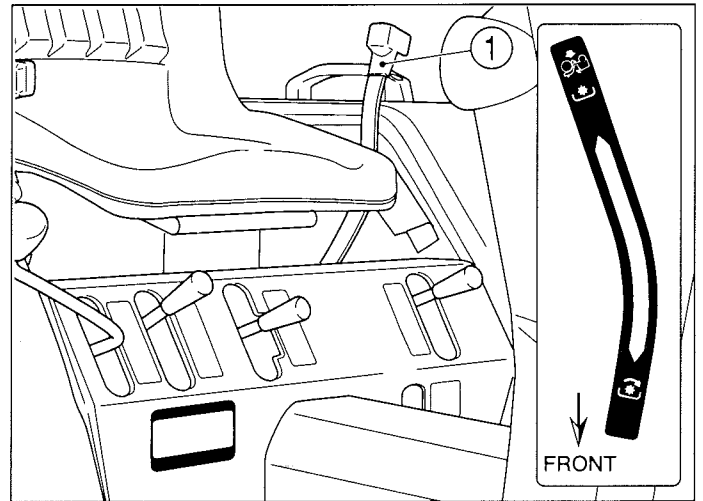

FIG. 54

**TM223**

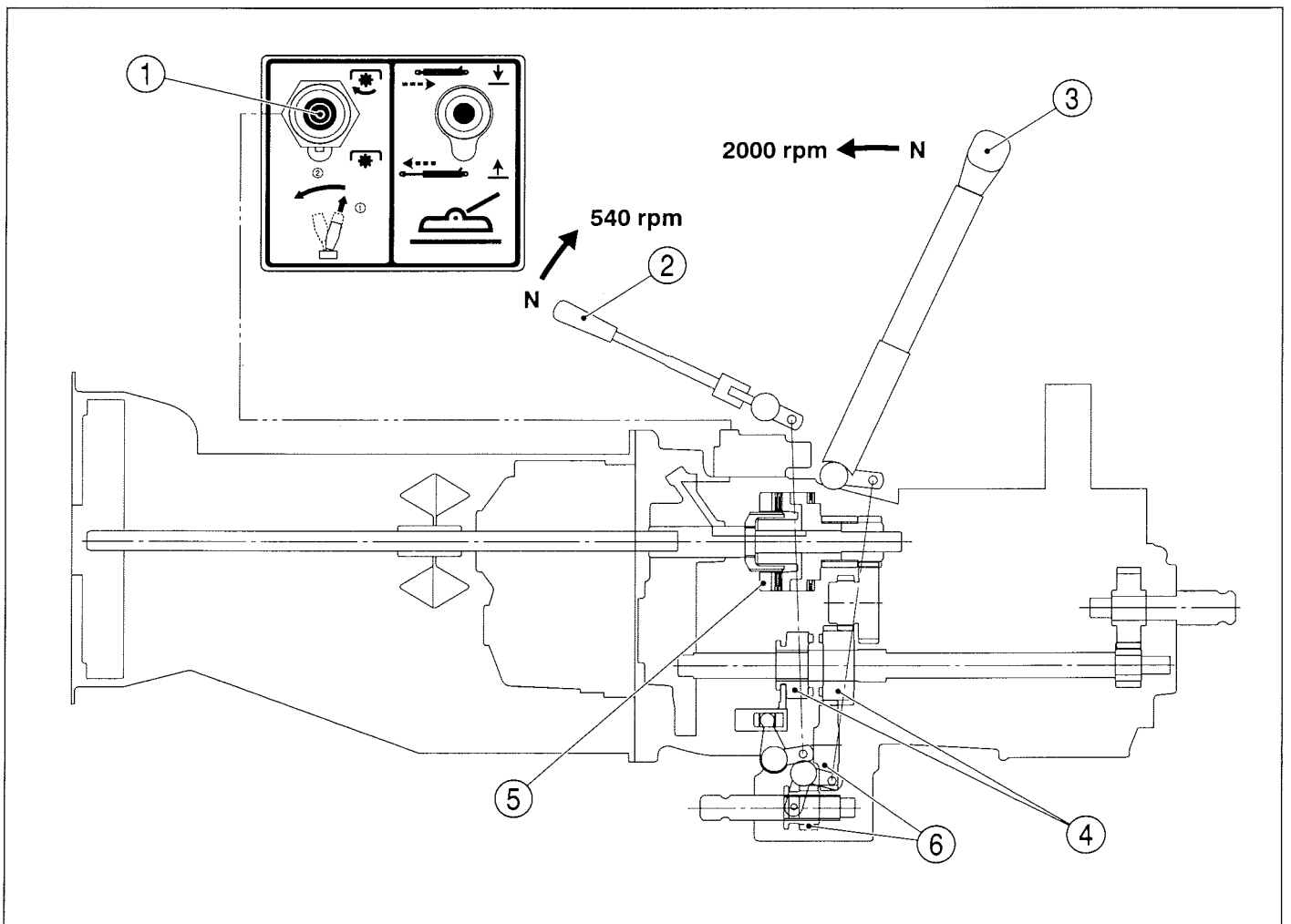



FIG. 55

FIG. 55 & 56: Rear PTO and mid PTO are both controlled by PTO control switch (1).

Rear PTO selector lever (2) is used to engage rear PTO gears inside the transmission housing.

To select a PTO - If the rear PTO is to be used, make sure PTO control switch is OFF and then pull rear PTO selector lever (2) upward to  position (540 rpm) to engage gear set (4).

If the mid PTO is to be used, make sure the PTO control switch is OFF and then push mid PTO selector lever (3) forward to  position (2000 rpm) to engage gear set (6).

If both PTO's are to be used, make sure PTO control switch is OFF and shift both control levers to the engaging positions.

To engage PTO - Lift PTO switch (1) and move forward to actuate hydraulic clutch (5) and complete the drive.

To disengage PTO - Move PTO control switch (1) rearwards to release hydraulic clutch (5).

**ALWAYS** move PTO control switch to OFF before shifting a PTO selector lever (2 or 3).

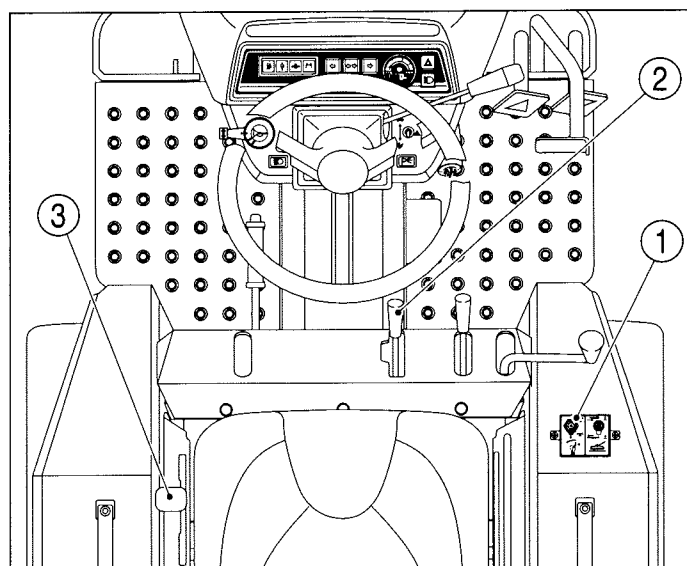

FIG. 56

### THREE-POINT HITCH

Three-point hitch combines the tractor and implement into one working unit. Implement positioning and raising are controlled hydraulically. In addition, implement weight and loads impose downward pressure to the tractor rear wheels to increase traction.

#### Hitch Controls

FIG. 57: Control quadrant, to the right of the operator's seat, controls the system which provides the following hitch control functions:

**Position Control** - Maintains the hitch position at constant height in relation to the tractor. As the position control lever (1) is moved rearward, the hitch (and

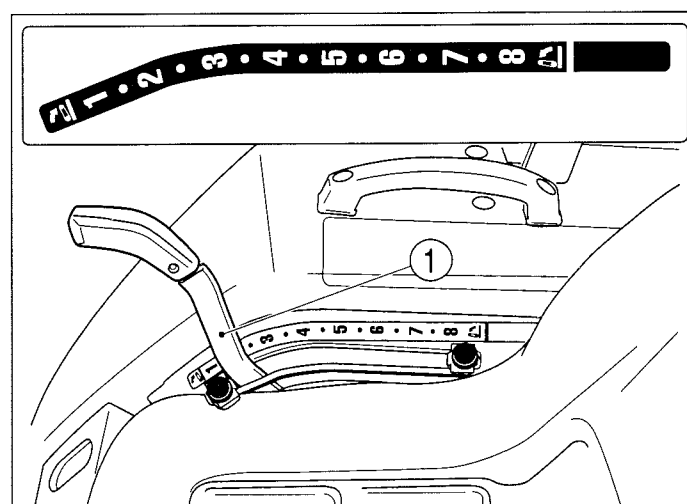

FIG. 57

## TM215F, TM217F & TM223F

implement) are raised. Moving the lever forward will lower the hitch to the selected position. Each lever setting provides a specific hitch (and implement) position.

FIG. 58: Lowering Rate Control Handle (2) controls the discharge rate of hydraulic oil thus adjusting lowering speed of the hitch and implement. Turn the handle clockwise to slow drop rate, counterclockwise to increase drop rate. Turning the handle fully clockwise will lock the implement in raised position.



**CAUTION:** When working on or around mounted implements, always lower them to ground prior to work. If an implement must be raised, always block the implement and the lower links securely.



**CAUTION:** Always shut off the PTO and shut off the tractor engine before servicing any PTO-driven implement. Allow all movement and motion to stop before leaving operator's seat.



**CAUTION:** Use the position control lever (1) when attaching or detaching an implements.

**NOTE:** When starting the engine, ensure the implement is lowered to the ground. This reduces load on the starter due to hitch trying to rise when the engine is cranked.

### Rear Linkage

FIG. 59: Linkage consists of several major components for implement attachment and operation:

**Lower Links (1)** - Primary attaching points to lower implement pins.

**Lift Rods (2)** - Connect the lower links to the hydraulic lift arms for raising/lowering of the lower links. The lift rod connected to the right lower link has provisions for levelling the implement (side to side).

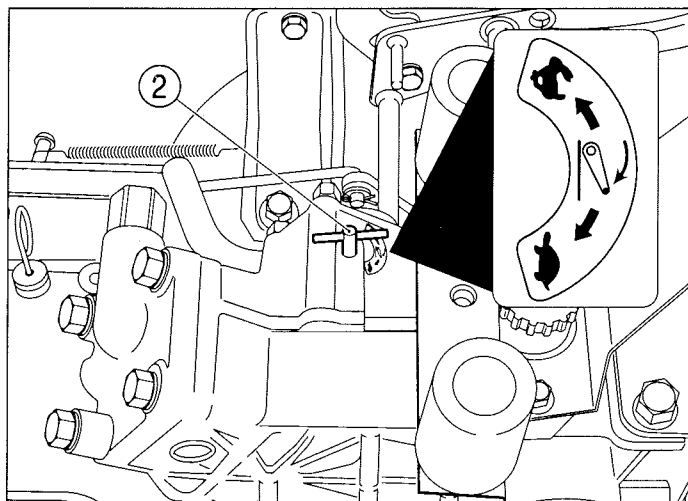

FIG. 58

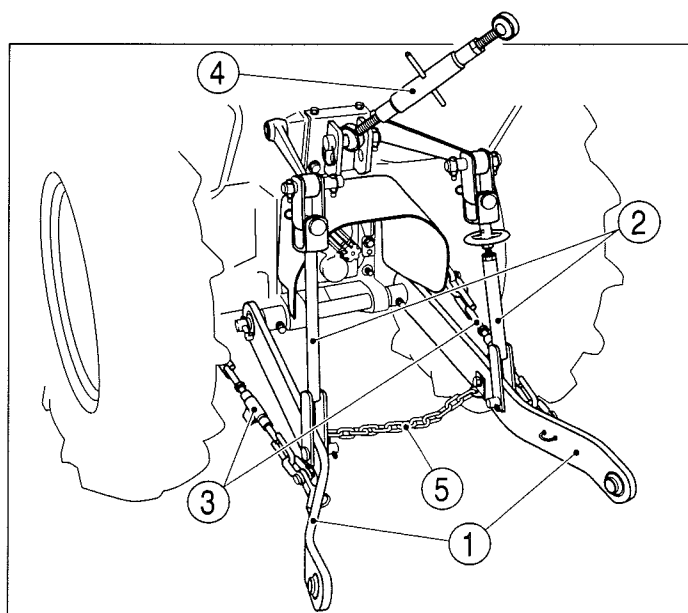

FIG. 59

**Check Chains (3)** - Reduce side sway of the implement.

**Top Link (4)** - Adjustable, turn-buckle type to level implement (front to rear). The top link also provides draft load sensing when accessory draft control is installed.

**Check Chain (5)** - Secures the lower links together to prevent tyre interference when the hitch is not used.

FIG. 60: Linkage provides two positions of connecting the top link (1) to the tractor.

For most implements, securing the top link (1) in the upper hole A is satisfactory, but position may be varied to provide increased implement height during transport.

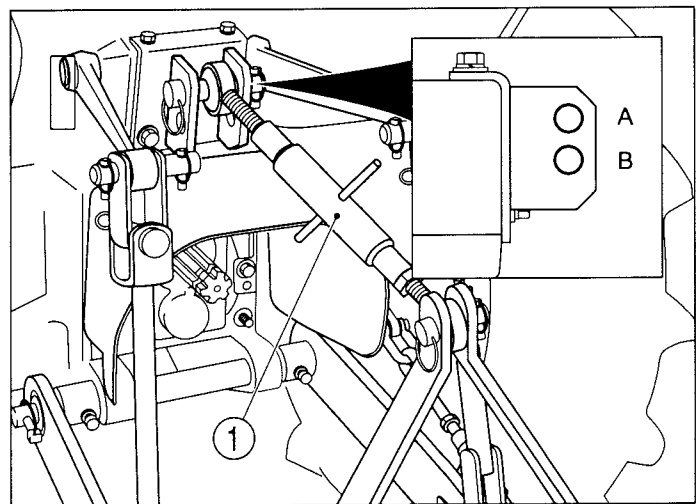

FIG. 60



**CAUTION:** *Secure all pins after adjustment is made. Always use pins supplied with the tractor.*

**Attaching Implements**



**CAUTION:** *Always use POSITION CONTROL to attach/detach implements to provide precise control of the hitch.*

FIG. 61: Reverse the tractor to the implement, centering the tractor with the implement hitch frame.

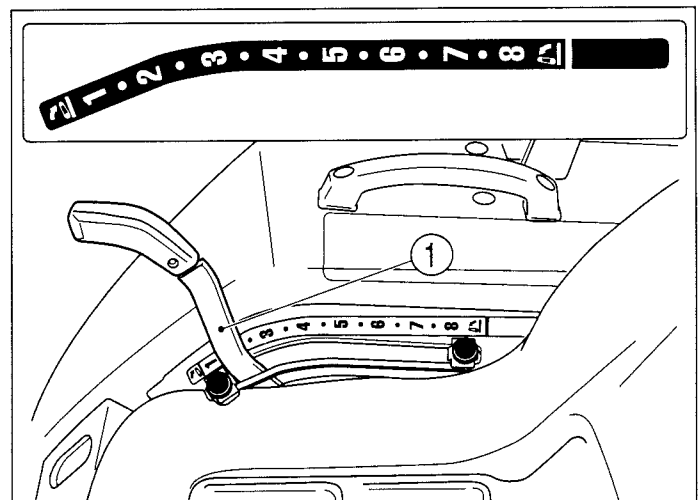

FIG. 61

Raise or lower the hitch using the position control lever (1) and align the left lower link end with the corresponding implement attaching pin. Lock the brakes, shut off the engine and remove the main switch key.

FIG. 62: Slide the ball end of the left lower link (1) over the implement pin and secure with a linchpin. Adjust height of the right lower link using the turn buckle (2). Attach and secure the right lower link (3) to the implement with a linchpin. Attach the top link (4) to the top of the implement hitch frame using the pin supplied with the tractor. Rotate the centre barrel section of the top link, to lengthen or shorten it, and level the implement from front to rear. After the implement is attached, it can be readjusted for level op-

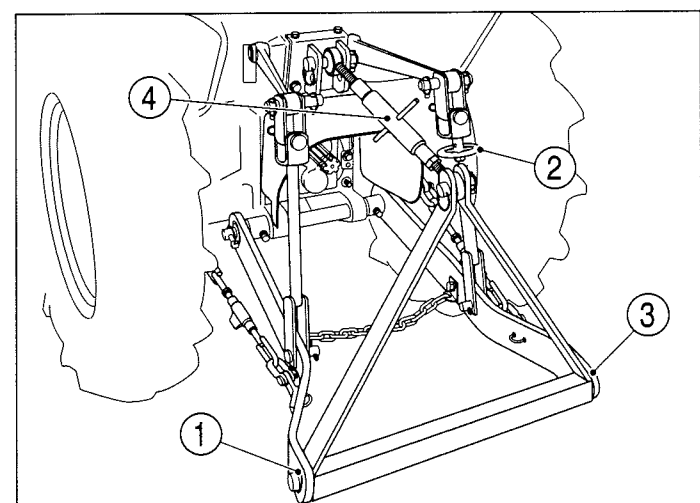

FIG. 62

## TM215F, TM217F & TM223F

eration using the lift rod and top link turn buckles. Assertain all adjustments are secure.

**IMPORTANT:** With some "mounted" implements, it will be necessary to remove the draw-bar at rear of the tractor to permit the implement to be raised and lowered without obstruction.

FIG. 63: Certain implements require minimal side-play. The stabilizer chain (1) at each lower link should be evenly adjusted to reduce side-play to the desirable level. Do not, however, eliminate all side-play as chain or lower link damage may result.

**NOTE:** The amount of side-play (stabilizer chain looseness) is dependent upon the implement to be mounted and type of operation. Normally 50 mm (2") of total side movement is desired, 25 mm (1") to each side of the tractor centre line.

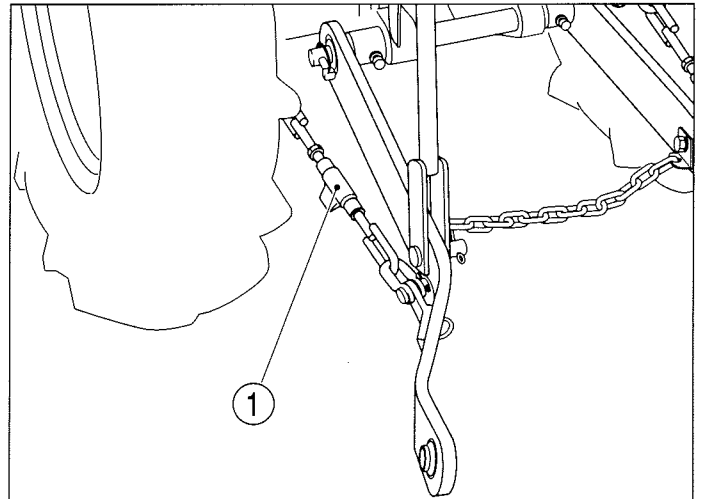

FIG. 63

### Using Position Control

**Function** - Attaching/detaching implements and operations requiring the implement to be kept at constant height above ground. Also used with tool bars having flexible row units and implements equipped with gauge (support) wheels.

FIG. 64: **Lever Positions** - Use the control lever (1) to adjust hitch and implement position.

**NOTE:** Front lever stop (2) can be set to contact position control lever in implement work position. This enables the implement to be returned to identical position after the hitch has been raised for turning, transporting, etc. Rear lever stop (3) can be set to limit raising height, if required.

**To Begin Work** - Align the tractor and implement in field and move the position control lever (1) forward (toward DOWN). Adjust implement height using the position control lever and set the adjustable stops (2) and (3) as desired.

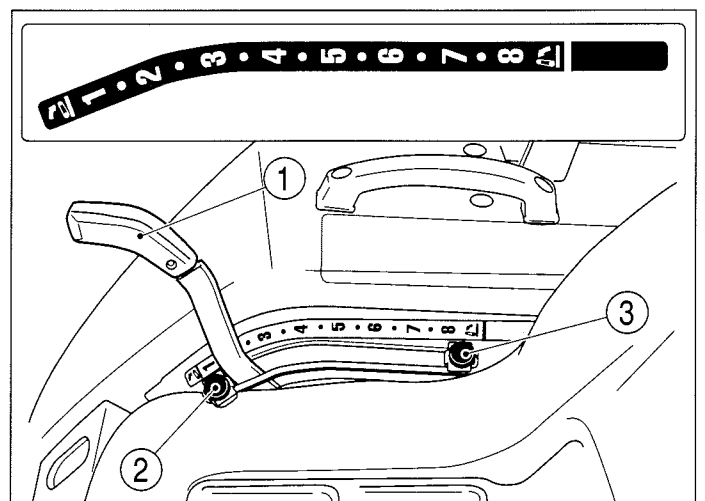

FIG. 64

**When Turning** - Move the position lever (1) rearward (toward Up) to raise the implement. Finish turning and return the lever against the lower stop to resume operation.

**To Finish Work and Transport** - Move the position control lever (1) fully rearward in the quadrant.

FIG. 65: Lowering speed can be readjusted as necessary using the lowering rate control handle (4). Turning the handle fully clockwise will prevent links from lowering.

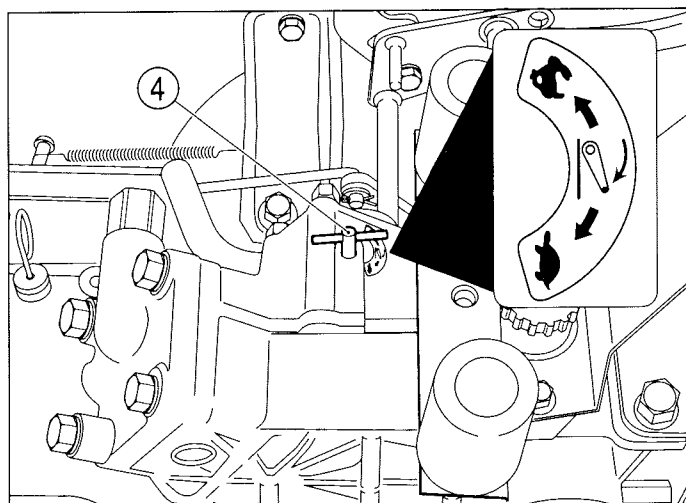

FIG. 65



**CAUTION:** When using a mounted implements with PTO driveline, make sure:

- PTO drive shaft has minimum 51 mm (2") engagement of telescoping sections at all hitch/implement positions.
- Hitch height during raising does not bind driveshaft universal joints due to extreme driveshaft angles.
- PTO drive is disengaged during transport.

### Detaching Implements



**CAUTION:** Always use **POSITION CONTROL** to attach/detach implements to provide precise control of the hitch.

Select a level to detach and store the implement.

Lower implement to ground by moving the position control lever to DOWN. If necessary, adjust the levelling crank on the right lift link to level the implement on ground.

Shut off the engine, securely lock the brakes and remove the main switch key from the tractor.

Disconnect the implement PTO driveshaft (as applicable). Detach the top link from the implement.

**NOTE:** Lengthening or shortening of the top link may be required to permit disconnection from the implement.

**TM215F, TM217F & TM223F**

FIG. 66: Disconnect the lower links from the implement pins. Make sure the lower links are connected together with the chain (1) to prevent tyre interference.

Take position in the operator's seat, start the engine and drive the tractor clear of the implement.

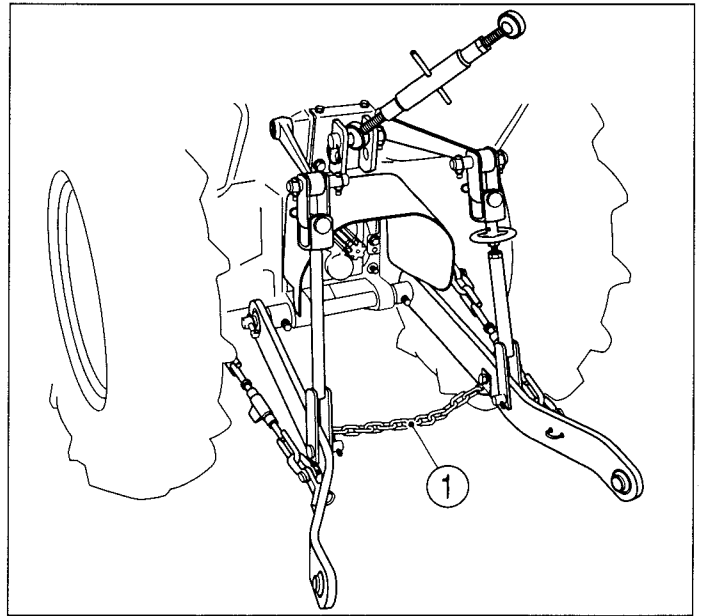

FIG. 66

# LUBRICATION & PERIODIC MAINTENANCE

## SPECIFICATIONS & CAPACITIES

### Engine Oil

Use engine oil of the appropriate SAE viscosity. Oil must meet or exceed; MIL-L-2104C requirements, API Service "CD".

|   | TM215               | TM217               | TM223               |
|---|---------------------|---------------------|---------------------|
| Capacity (litres) .....                 | 2.7                 | 2.7                 | 2.7                 |
| Recommended Viscosity:                  |                     |                     |                     |
| 78 °F (25 °C) and Above .....           | SAE 30 W, 10 W - 30 | SAE 30 W, 10 W - 30 | SAE 30 W, 10 W - 30 |
| 32° - 78 °F (0° - 25 °C) .....          | SAE 20 W, 10 W - 30 | SAE 20 W, 10 W - 30 | SAE 30 W, 10 W - 30 |
| Below 32 °F (0 °C) .....                | SAE 10 W, 10 W - 30 | SAE 10 W, 10 W - 30 | SAE 30 W, 10 W - 30 |
| Recommended Change Intervals:           |                     |                     |                     |
| Initial Oil and Filter Change .....     | 50 hours            | 50 hours            | 50 hours            |
| Oil and Filter Change, Thereafter ..... | Every 150 hours     | Every 150 hours     | Every 150 hours     |

### Engine Coolant

|   |   |   |   |
|---|---|---|---|
| Freezing Protection (Original factory Fill) ..... | -34 °C (-30 °F)                         | -34 °C (-30 °F)                         | -34 °C (-30 °F)                         |
| Recommended Coolant .....                         | 50/50 mixture ethylene glycol and water | 50/50 mixture ethylene glycol and water | 50/50 mixture ethylene glycol and water |
| System Capacity (litres) .....                    | 5.1                                     | 5.1                                     | 7.1                                     |

### Fuel Tank

|                          |                  |                  |                  |
|--------------------------|------------------|------------------|------------------|
| Capacity (litres) .....  | 13.5             | 13.5             | 23               |
| Fuel recommended,        |                  |                  |                  |
| Above 4 °C (39 °F) ..... | No. 2 or No. 2-D | No. 2 or No. 2-D | No. 2 or No. 2-D |
| Fuel Recommended,        |                  |                  |                  |
| Below 4 °C (39 °F) ..... | No. 1 or No. 1-D | No. 1 or No. 1-D | No. 1 or No. 1-D |

### Transmission & Differential Housing (Including Hydraulic System)

|  |   |   |   |
|--|---|---|---|
| Capacity (litres)  |   |   |   |
| F .....  | 13.5                                      | 13.5                                      | —   |
| FU (with Power-assisted steering) .....  | —   | 14.0                                      | —   |
| FMU (with Mid-mount PTO and Power-assisted steering) .....                             | 14.0                                      | 14.0                                      | —   |
| FHU (with HST and Power-assisted steering) .....                                       | 15.0                                      | 15.0                                      | —   |
| FHMU (with HST, Mid-mount PTO and power-assisted steering) .....                       | 15.0                                      | 15.0                                      | —   |
| FHSME (with HST, Independent PTO, and Mid-mount PTO and Power-assisted steering) ..... |   |   | 14.0                                      |
| Recommended Lubricant .....  | Shell DONAX TD or equivalent              | Shell DONAX TD or equivalent              | Shell DONAX TD or equivalent              |
| Recommended Change Interval .....  | First 50 hours every 200 hours thereafter | First 50 hours every 200 hours thereafter | First 50 hours every 200 hours thereafter |

### Front Axle

|  |                 |                 |                 |
|--|-----------------|-----------------|-----------------|
| Capacity (Common Reservoir) (litres) ..... | 2.7             | 2.7             | 2.7             |
| Recommended Change Lubricant .....         | SAE 80 GL-4     | SAE 80 GL-4     | SAE 80 GL-4     |
| Recommended Change Interval .....          | Every 300 hours | Every 300 hours | Every 300 hours |

### Grease Fittings

|  |                           |                           |                           |
|--|---------------------------|---------------------------|---------------------------|
| Greasing Interval (All Fittings) ..... | Every 50 hours            | Every 50 hours            | Every 50 hours            |
| Recommended Grease .....               | Lithium base grease No. 2 | Lithium base grease No. 2 | Lithium base grease No. 2 |

**NOTE:** Change intervals stated above are for normal usage. Due to adverse operating conditions that may be experienced (extremely dusty or muddy), change intervals may need to be more frequent.

**TM215F, TM217F & TM223F**

**LUBRICATION/FILL POINTS**

FIG. 67: General layout of lubrication, fill and drain locations on the tractor:

| Ref. | Description:       | Type:          |
|------|--------------------|----------------|
| 1    | Fuel Tank          | Diesel Fuel    |
| 2    | Radiator           | Engine Coolant |
| 3    | Engine             | Engine Oil     |
| 4    | Transmission Case  | Hydraulic Oil  |
| 5    | Front Axle         | Hydraulic Oil  |
| 6    | Axle Pivots        | Grease </td    |
| 7    | Clutch Shaft       | Grease </td    |
| 8    | HST pedal          | Grease </td    |
| 9    | Brake pedal        | Grease </td    |
| 10   | Drag Rod & Tie-rod | Grease         |
| 11   | Steering Gearbox   | Hydraulic Oil  |
| 12   | Knuckle Arm        | Grease         |

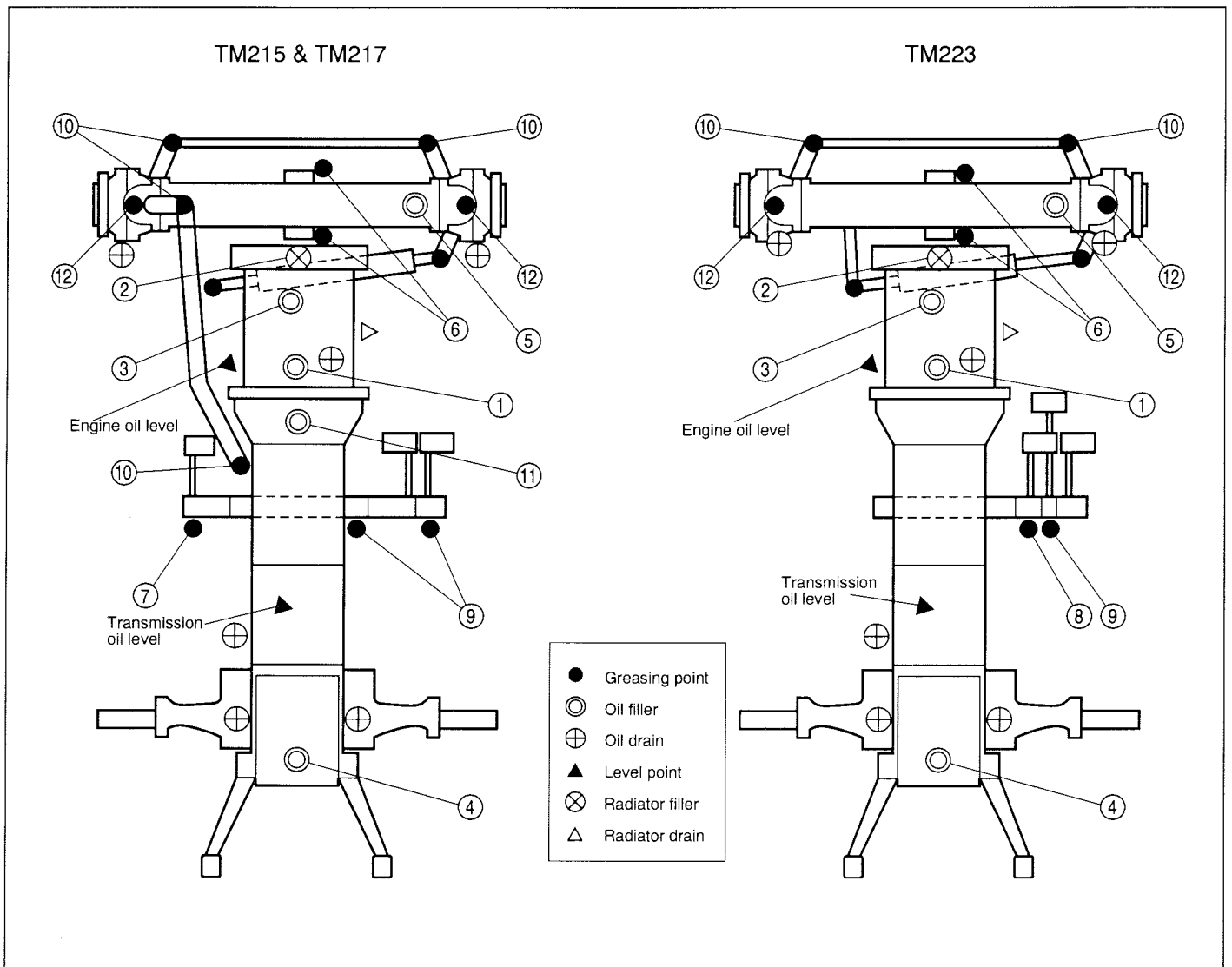

FIG. 67

**PERIODIC MAINTENANCE SCHEDULE**

| Recommended Interval, Each: |       |        |        |        |      | Item To Check  | Action Required           | Pages Ref. |
|-----------------------------|-------|--------|--------|--------|------|--|---------------------------|------------|
| Day                         | 50 hr | 150 hr | 200 hr | 300 hr | Year |  |                           |            |
| ●                           |       |        |        |        |      | All controls, switches                                       | Inspect and repair        | —          |
| ●                           |       |        |        |        |      | All fasteners, hardware                                      | Check and tighten         | —          |
| ●                           |       |        |        |        |      | Hoses, fan belt, wiring                                      | Inspect and repair        | —          |
|                             | ●     |        |        |        |      | Grease fittings  | Lubricate                 | 48, 50     |
| ●                           |       |        |        |        |      | Engine oil level   | Replace                   | 51         |
|                             | (*)   | ●      |        |        |      | Engine oil & filter  | Check and replenish       | 51         |
| ●                           |       |        |        |        |      | Transmission oil level                                       | Replace and clean         | 52         |
|                             | (*)   |        | ●      |        |      | Transmission oil & screen                                    | Replace cartridge         | 53         |
|                             | (*)   |        | ●      |        |      | Hydrostatic oil filter                                       | Replace cartridge         | 54         |
|                             | ●     |        |        |        |      | Front axle oil level   | Replace                   | 54         |
|                             |       |        |        | ●      |      | Front axle oil   | Clean of debris           | 54         |
| ●                           |       |        |        |        |      | Air screens & radiator                                       | Check and replenish       | 55         |
|                             |       |        |        |        | ●    | Radiator coolant   | Drain, flush & replace    | 55         |
| ●                           |       |        |        |        |      | Fan belt tension   | Check and adjust          | 55         |
| ●                           |       |        |        |        |      | Air cleaner dust ejector                                     | Clean                     | 56         |
|                             | ●     |        |        |        |      | Air cleaner elements   | Inspect, clean or replace | 57         |
| ●                           |       |        |        |        |      | Fuel tank level  | Fill                      | —          |
| ●                           |       |        |        |        |      | Fuel filter sediment bowl                                    | Inspect, clean and bleed  | 57, 58, 59 |
|                             | ●     |        |        |        |      | Battery & cables   | Check, clean & tighten    | 60         |
|                             | ●     |        |        |        |      | Battery electrolyte level                                    | Check and replenish       | 61         |
| ●                           |       |        |        |        |      | Lights, flashers & horn                                      | Check and repair          | —          |
| ●                           |       |        |        |        |      | Clutch pedal free-play <sup>(TM215)</sup> <sub>(TM217)</sub> | Check and adjust          | 63         |
| ●                           |       |        |        |        |      | Brake adjustment & balance                                   | Check and adjust          | 64         |
| ●                           |       |        |        |        |      | Tyre pressure & condition                                    | Check and adjust          | 66         |
| ●                           |       |        |        |        |      | Wheel bolt torque  | Check and adjust          | 66         |
| ●                           |       |        |        |        |      | Steering free-play   | Check and repair          | 67         |
|                             |       |        |        | ●      |      | Front axle end-float   | Check and adjust          | 68         |
|                             |       |        |        |        | ●    | Clutch housing leaks   | Remove plug & check       | 69         |

Items marked (\*) indicate initial service interval only. Subsequent (later) intervals marked "●". Intervals above are for normal usage. Severe operating conditions (wet, dusty, etc.), or when previous servicing has indicated need for more frequent action, intervals may need to be shortened.

## SERVICE ACCESS



**CAUTION:** *Shut off the engine before servicing the tractor. Hood side panels and front grille must be installed and secured prior to operating the tractor.*

FIG. 68: To gain access to the radiator, battery and engine components, the right and left hood side panels can be easily removed.

To remove; turn locking knobs (1) to unlock. Pull outward on the bottom edge, and then the lift side panel upward to disengage and remove it.

Reinstall in reverse order making sure the top edge of the side panel engages correctly. Push inward on the bottom edge and turn the knobs (1) to lock.

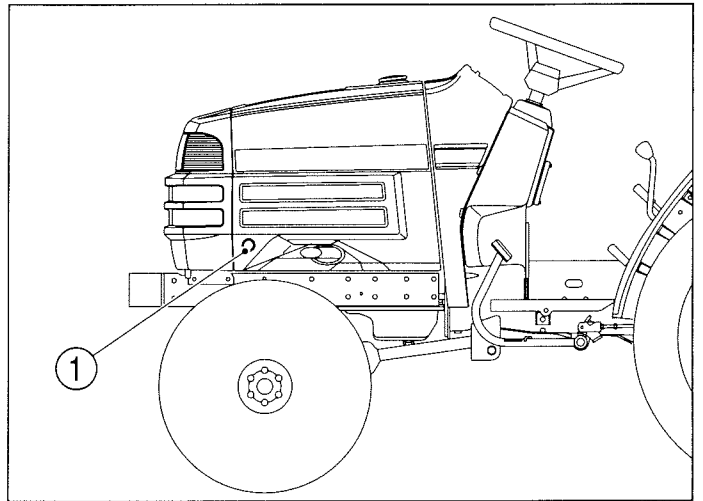

FIG. 68

FIG. 69: To remove the battery, the front grille should be removed.

To remove; give locks (1) one-quarter turn counter-clockwise. Tip the top of grille outward and disconnect the headlamp wiring couplers (2). Lift the grille upward to disengage the lower hooks and remove it from the tractor.

Reinstall in reverse order making sure the lower hooks engage on pins. It will be necessary to push inward on the locks (1) and then give them one-quarter turn clockwise to secure.

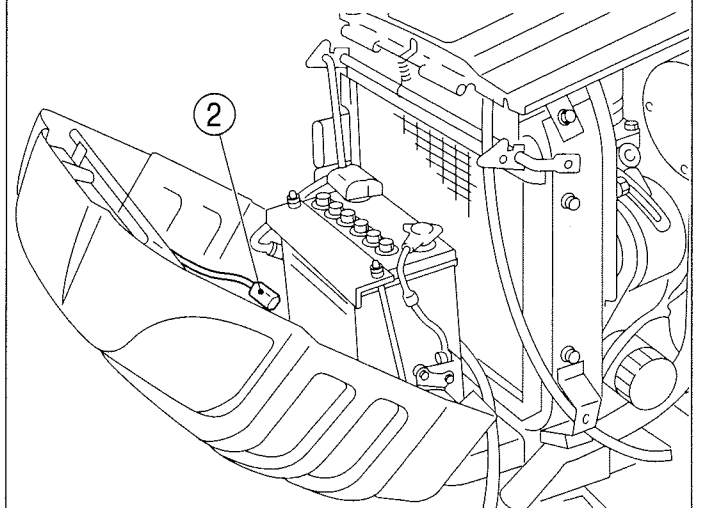
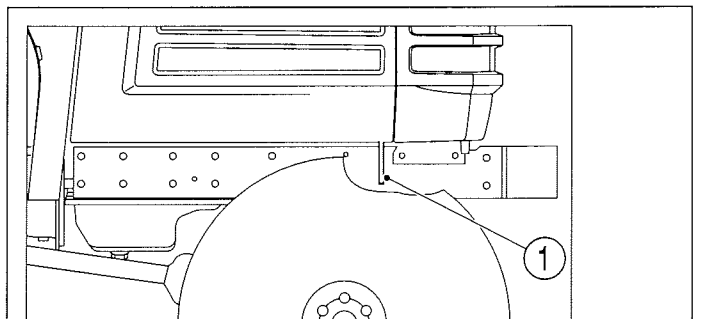

FIG. 69

## LUBRICATION DETAILS

### Grease Fittings

Lubricate all grease fittings (refer to Fig. 67) every 50 hours of operation using No. 2 multipurpose lithium-base grease. Clean the grease gun and fittings before and after greasing to prevent contamination from dirt.

**NOTE:** *When operating in muddy or extremely wet conditions, daily lubrication of fittings is recommended.*

**Engine Oil & Filter**

Engine oil and the filter should be changed after the first 50 hours of operation and then every 150 hours thereafter.

FIG. 70: To Check Engine Oil Level - The tractor must be parked on level ground with the engine off. Pull out the dipstick (1) and check that oil level is between upper limit F and lower limit L on the dipstick. Wipe off the dipstick, momentarily reinstall it in the engine and check oil level again.

Add oil through the dipstick/filter opening as required.

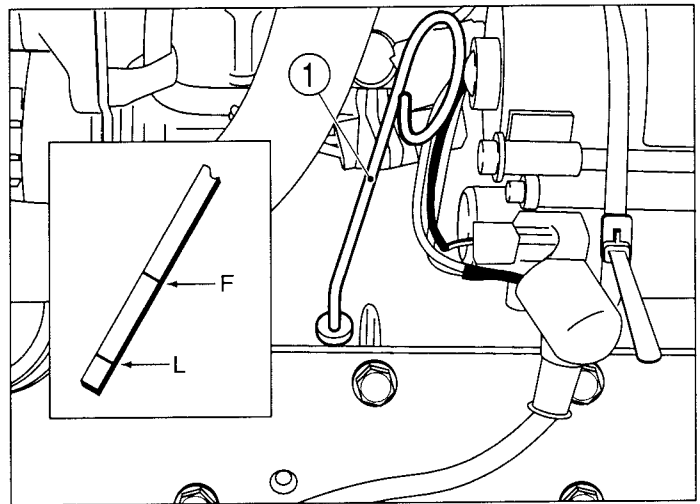

FIG. 70



**DANGER:** *Muffler tail pipe is extremely hot just after operation, so take care not to touch it to avoid burns. Be sure to wear gloves before checking engine oil level.*

FIG. 71: To add oil, open the door (2) on the top of the engine hood and remove the filter cap (3). Add oil using a funnel (4) to prevent oil from spilling.

**NOTE:** *Add oil slowly to assist in venting air from the crankcase.*

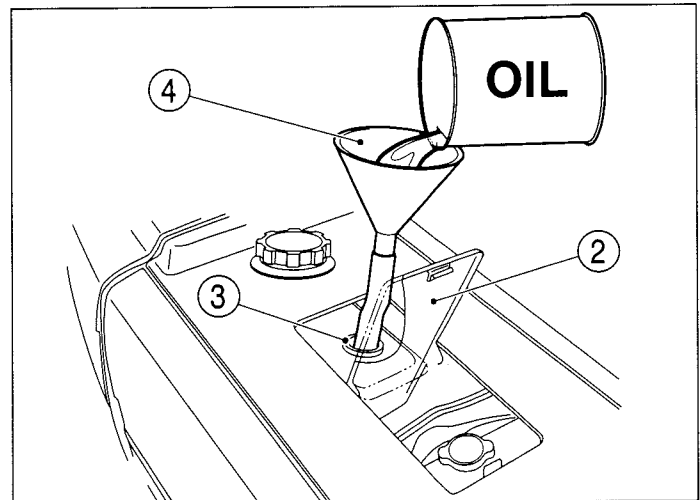

FIG. 71

FIG. 72: To Change Engine Oil - Operate the tractor until oil is adequately warmed. Remove the drain plug (5) from the engine and allow all oil to drain out.

Reinstall the drain plug and fill the engine crankcase to the upper limit on the dipstick.

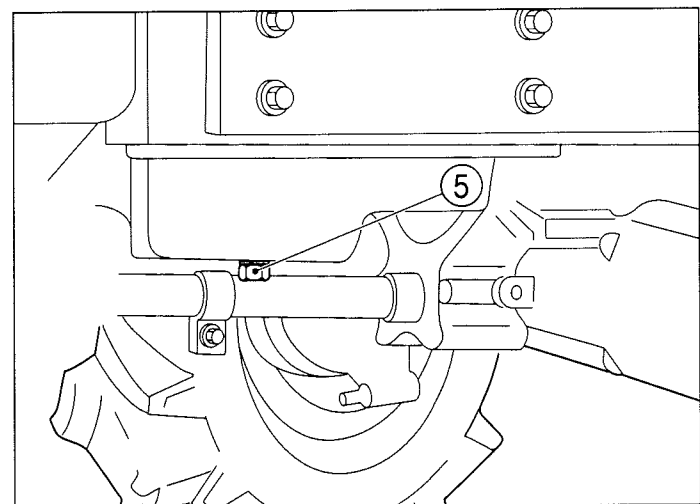

FIG. 72

## TM215F, TM217F & TM223F

FIG. 73, 74 & 75: To Replace Engine Oil Filter - Unscrew the element (6) from the engine and discard. Make sure the original filter gasket has been removed.

Lubricate the new gasket on the replacement element with clean engine oil. Screw on the new element until the gasket contacts the adapter and then tighten element by further 2/3 turn.

Clean spilled oil and refill the crankcase. Start the engine, check for leaks and replenish oil level as required.

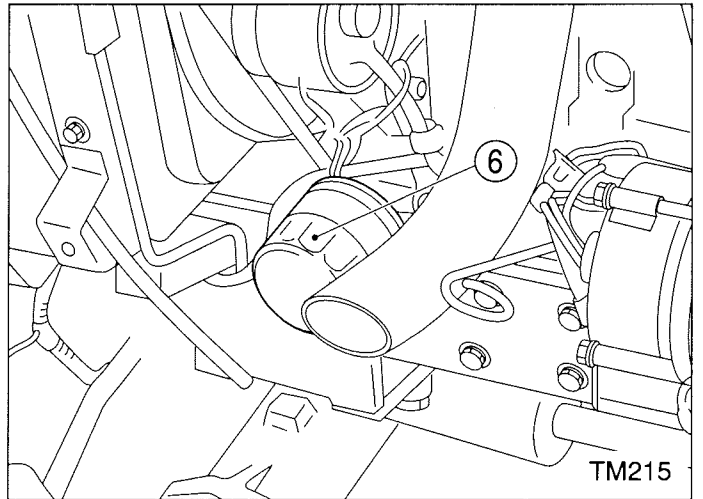

FIG. 73

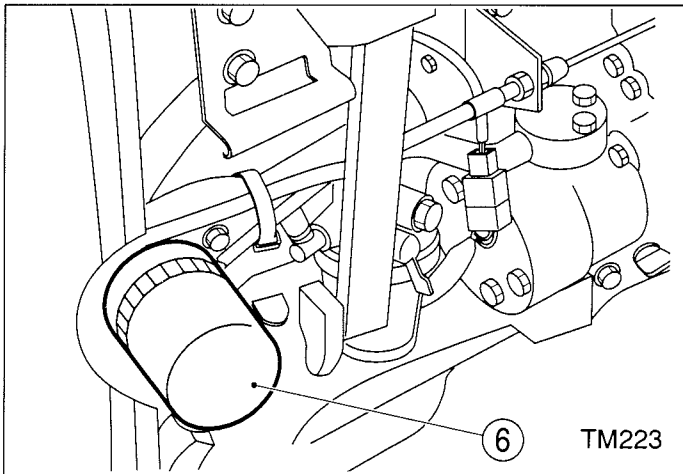

FIG. 75

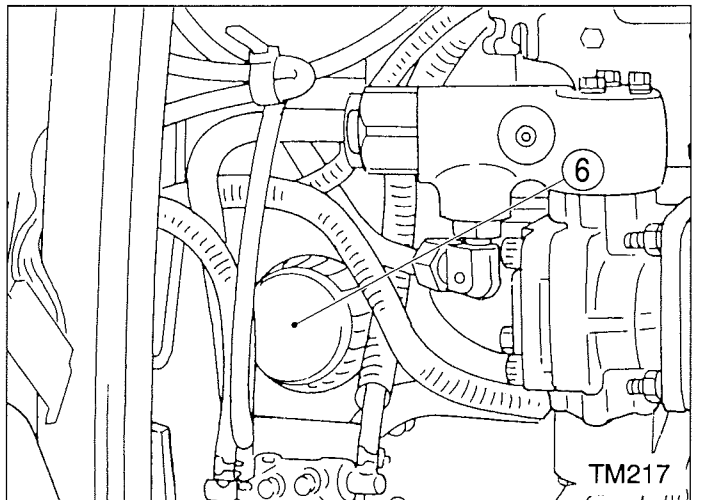

FIG. 74

## Transmission Oil & Filters

Transmission oil lubricates the transmission, centre housing, and rear axles and also serves as hydraulic fluid. Transmission oil and the filter should be changed after the first 50 hours of operation and then every 200 hours thereafter.

FIG. 76: To Check Transmission Oil Level - Park the tractor on level ground and remove the dipstick (1). Oil level should be indicated between the upper limit A and the end of dipstick B.

Oil level is replenished, as necessary, by removing the filler plug (2) and adding oil through the filler opening.

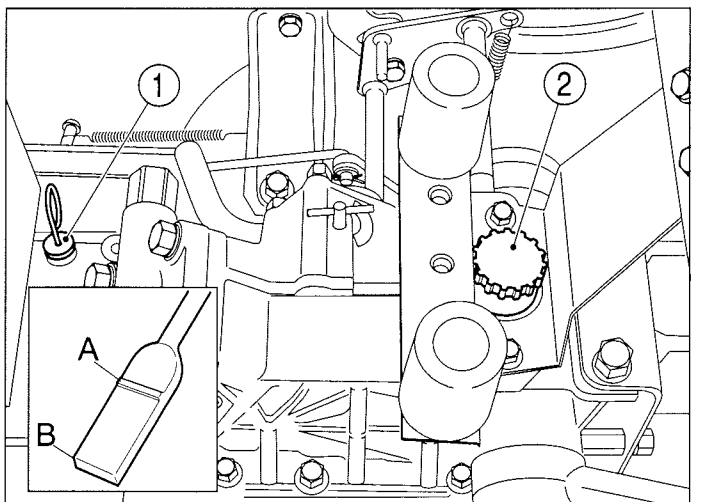

FIG. 76

**NOTE:** Adding oil to the transmission will also maintain correct oil level in the centre housing and rear axles.

FIG. 77: To Replace Transmission Oil - Remove the drain plug (1) along with second drain plug (2) below the mid PTO gearbox, and the final drive plugs (3) on each axle. Completely drain oil from the system.

**IMPORTANT:** *Completely lower the three-point hitch prior to draining transmission oil. When completely drained replace and tighten all drain plugs. Refill with oil as outlined above.*

To Clean Hydraulic Oil Filter - Clean the hydraulic oil filter while oil is removed. Unscrew the bolt (4) and turn the filter housing (5) downward after having loosened the bolt (6) while holding the spacer (7). Take out the filter (8). Clean it in solvent or kerosene, dry thoroughly and reinstall. Make sure "O" rings are not damaged.

Refill the system with clean oil to level as detailed.

Start the tractor and allow the engine to idle several minutes while operating the hydraulic controls. Shut the engine off, lower the three-point hitch and re-check oil level. Replenish transmission oil as necessary. Check for leaks and correct as necessary.

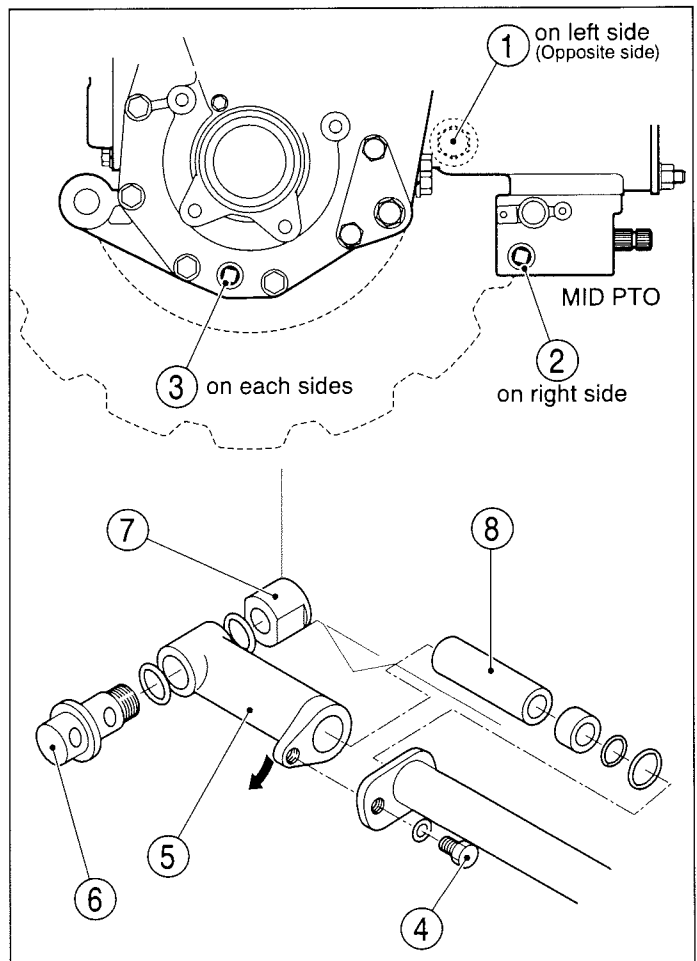

FIG. 77



**Caution:** *After transmission oil has been replaced or, before the tractor is put in motion after a long term of storage, or when the hydraulic system does not function properly, bleed air from the hydraulic oil circuit as follows:*

Fig. 78: To bleed air from the hydraulic system—Loosen plug (1) by one turn or one turn and a half. NEVER remove the plug, or oil will be ejected through the plug hole during air-bleeding operation. Start the engine and operate it at full throttle.

Overflowing of oil through the plug shows air-bleeding has been completed. Stop the engine and retighten the plug.

**Note:** *When no oil overflows through the plug, try loosening the plug by another half turn.*

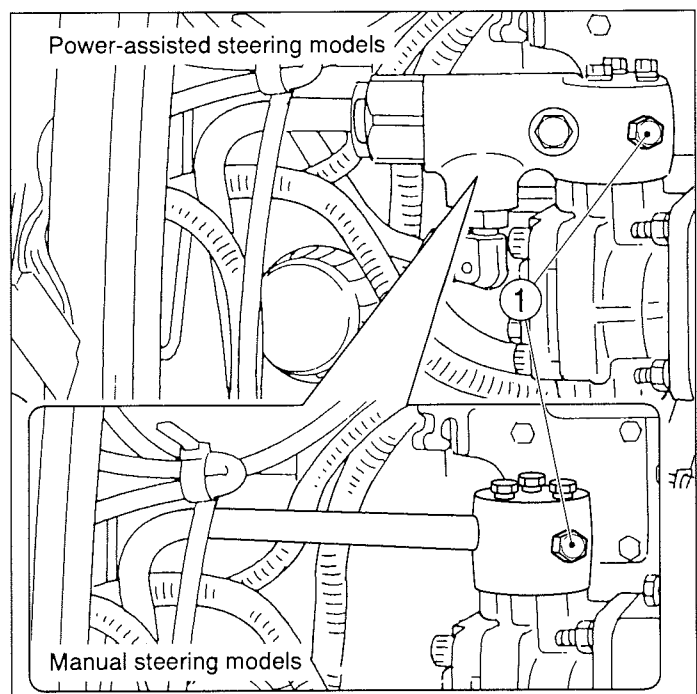

FIG. 78

## Hydrostatic Cartridge Oil Filter Replacement

The hydrostatic cartridge oil filter is located under the left step.

FIG. 79: Always replace the hydraulic oil filter while oil is removed. Carefully unscrew the oil filter (1) from its adapter. Use of a filter wrench may be necessary.

Clean the filter adapter and lubricate the gasket on the replacement filter with clean hydraulic oil. Install the new filter until gasket contacts the adapter and tighten additional 2/3 turn by hand. Do not use a filter wrench to install the filter.

Replace the cartridge after the first 50 hours, and then every 200 hours.

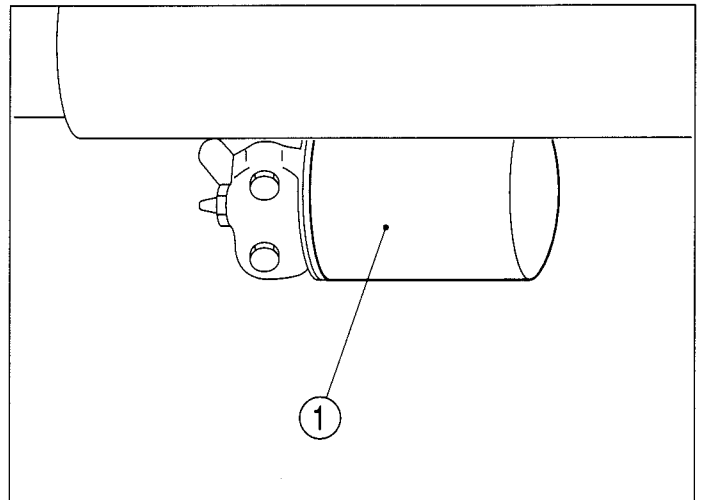

FIG. 79

## Front Axle Oil

Front drive axle has a common oil level for front differential housing and each wheel reduction unit. Oil level should be checked every 50 hours of tractor operation and replaced after every 300 hours.

FIG. 80: To Check Oil Level - Park the tractor on level ground and then remove the oil level plug (1). Oil should be level with or slightly below the level plug opening. Remove the fill plug (2) and add oil until oil is expressed from the level plug opening. Replace the level plug and fill plug.

To Change Oil - Remove the drain plug (3) from both wheel reduction units. When all oil has drained out, replace the drain plugs and fill the housing to the level plug opening. Replace the level plug and filling plug.

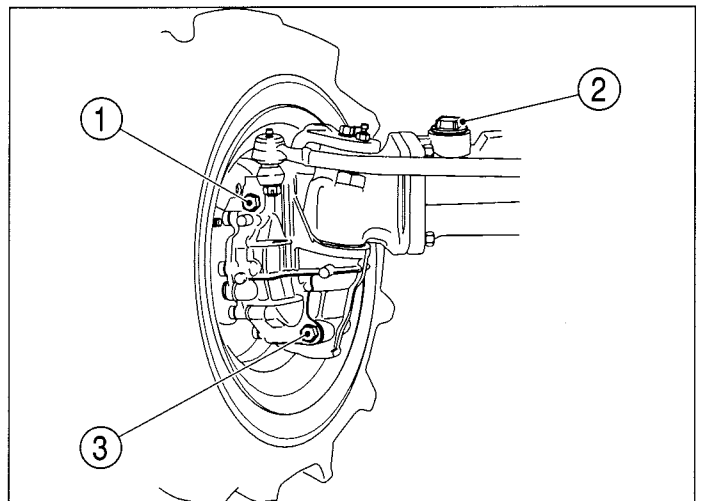

FIG. 80

COOLING SYSTEM



**CAUTION:** *DO NOT* remove the radiator cap when the engine is hot. After engine has cooled down, rotate the cap slowly to release pressure. Then the cap can be safely removed.

FIG. 81: Cooling system is filled at factory with anti-freeze solution to protect the engine and radiator to -34°C (-30°F). Cooling level should be maintained to 12 mm (1/2") below the filler neck opening (1). Check coolant annually as a precaution against freezing.

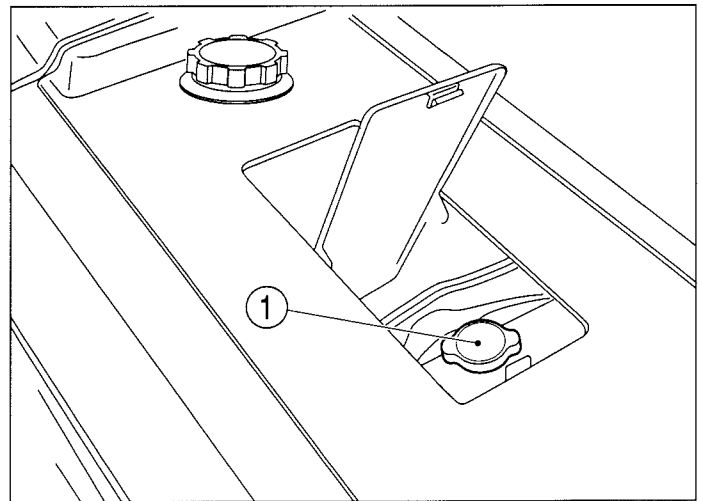

FIG. 81

**NOTE:** *After adding coolant, start the engine and let it run until thoroughly warmed so coolant is mixed.*

Periodically check the condition of hoses, belt and clamps and tighten or replace as necessary.

Keep the radiator, radiator screen and hood screens clean to permit maximum cooling.

**IMPORTANT:** *Use care when cleaning the radiator to prevent cooling fin damage.*

FIG. 82: Drain cock (2) will drain coolant from the cylinder block and radiator. The drain cock is located on the right side of the engine. Coolant should be replaced if it becomes contaminated with rust or sludge. Loosening the radiator cap will assist draining.

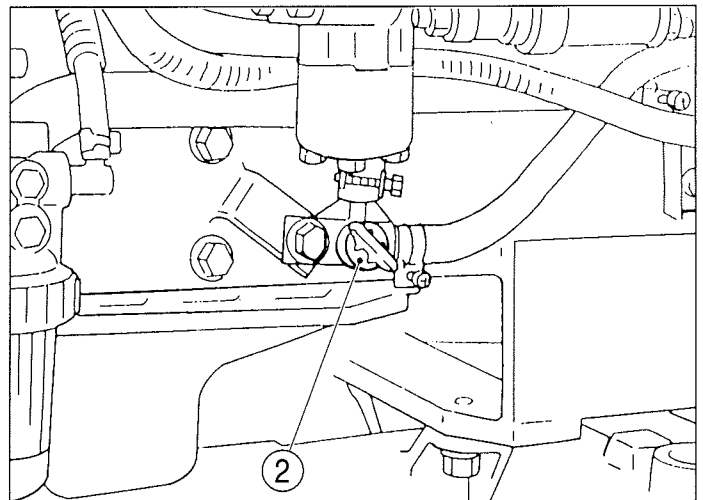

FIG. 82

**NOTE:** *Before adding new coolant, flush inside of the radiator and engine block with clean water.*

The radiator and engine must be drained if freezing temperatures are expected and the cooling system is not filled with sufficient to provide adequate protection from freezing.

FIG. 83: Correct fan belt tension helps to insure adequate coolant flow through the cylinder block and radiator. The belt is correctly tensioned when belt deflection is approximately 12 mm (1/2") as shown at

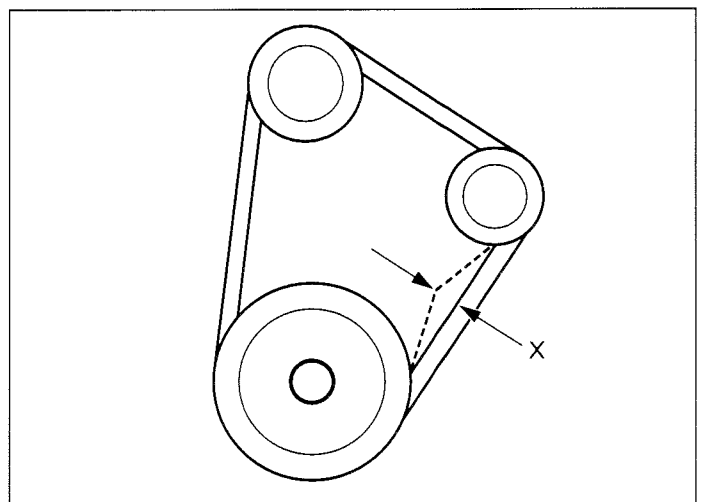

FIG. 83

## TM215F, TM217F & TM223F

“x” when thumb pressure is exerted at the centre of belt span.



**CAUTION:** Due to muffler position, allow it to cool before checking or adjusting fan belt tension.

FIG. 84: To adjust belt tension, loosen the alternator pivot bolt and nut (1) and tensioning bracket bolt (2). Pull outward on top of the alternator to correctly tension belt and tighten the bolt (2) first and then tighten the pivot bolt (1).

**IMPORTANT:** Do not pry against the alternator housing or pulley. Carefully pry against the alternator mounting flange to prevent damage.

### ENGINE AIR CLEANER

**IMPORTANT:** Never operate the engine with the air filters removed.

FIG. 85: The engine air cleaner is located above the engine. To gain access remove the right side panel.

The dust ejector (1) should be squeezed daily to open it and allow dust to drop out. This will reduce amount of material which collects on the main filter.

To service the main filter, release the retaining band (2) over the air cleaner and pull the air cleaner inlet tube to rear to release it from the retaining hooks, then turn the air cleaner out for servicing.

FIG. 86: Release clips and uncover. Remove the element. Examine the element and seals for damage and brittleness. If the element is damaged in any way it must be replaced.

**NOTE:** Fit the seal ring of the filter correctly when reinstalling.

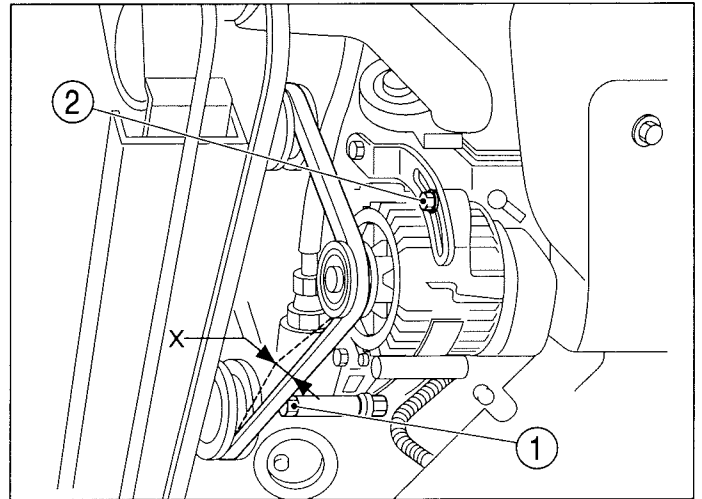

FIG. 84

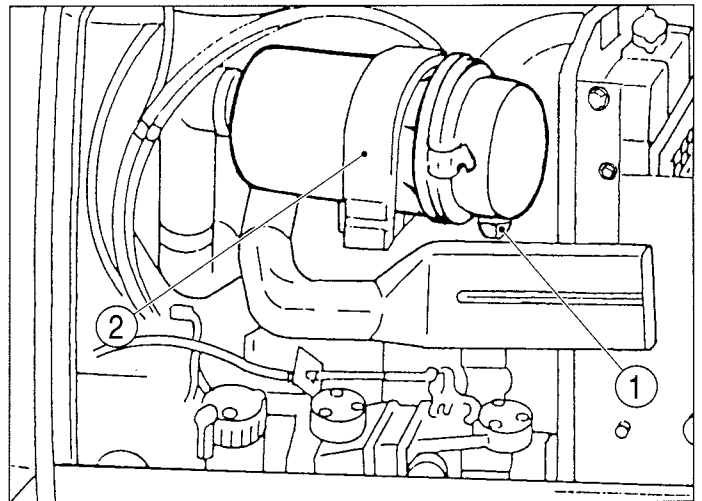

FIG. 85

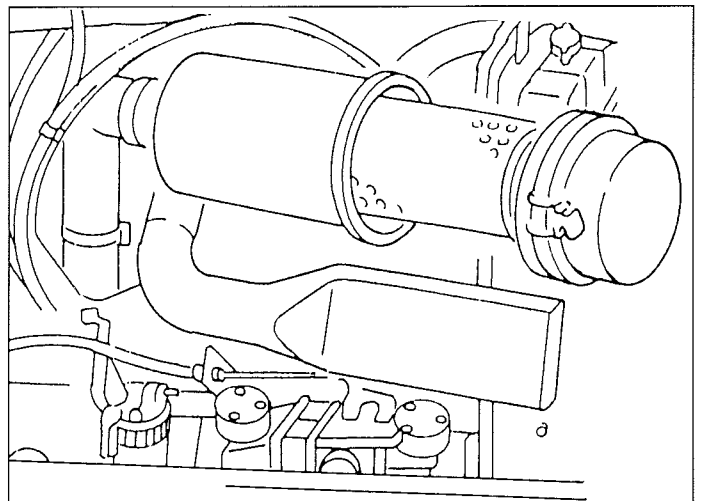

FIG. 86

FIG.87: Element may be cleaned (if in serviceable condition) using following procedures:

- Using compressed air not to exceed 200 kPa (30 psi) from the inside of the element, remove loose dirt, grass, chaff, etc. Be careful not to damage element pleats with air flow.
- If the element is coated with oil or soot:
  1. Prepare solution of warm water and non-foaming detergent .
  2. Soak the element for thirty minutes.
  3. Agitate the element in solution until oil and soot are loosened.
  4. Rinse the element until rinse water is clear.
  5. Allow the element to completely dry. Do not dry by using compressed air or heat.
- After cleaning (or washing) the element examine for pin holes, punctures, or tears. If the element paper, canister or seal show any signs of physical damage, the element must be replaced.

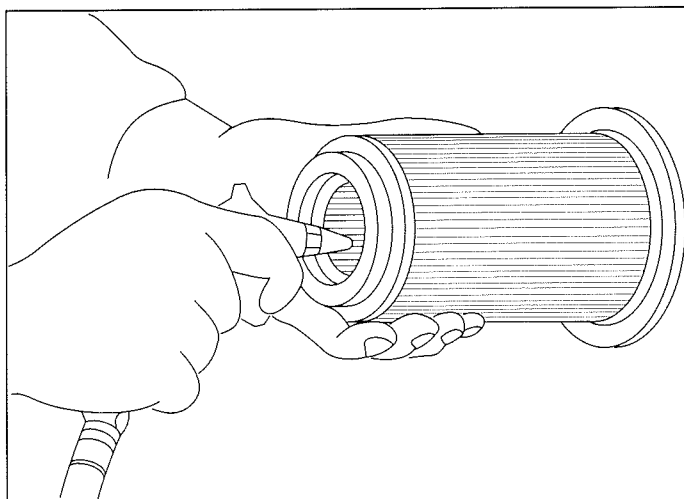

FIG. 87

*NOTE: Replaced an element which has already been washed five times.*

## FUEL SYSTEM

Use only clean diesel fuel of correct grade. Introduction of water or dirt into the fuel tank or other part of the fuel system can cause repeated plugging of the fuel filter and possible injection pump and injector damage.

**IMPORTANT:** *Do not tamper with the injection pump of injector adjustments as doing so may render the engine and/or tractor warranty void and may cause severe engine damage. Refer to a local ISEKI Dealer.*

### Fuel Filter

FIG. 88: Fuel filter assembly (1) is located at the right side of the engine, and is used to strain impurities from fuel before fuel reaches the injection pump. The fuel filter incorporates the valve (2) to aid in filter servicing.

Check the filter bowl for accumulation of sediment or water and clean as required.

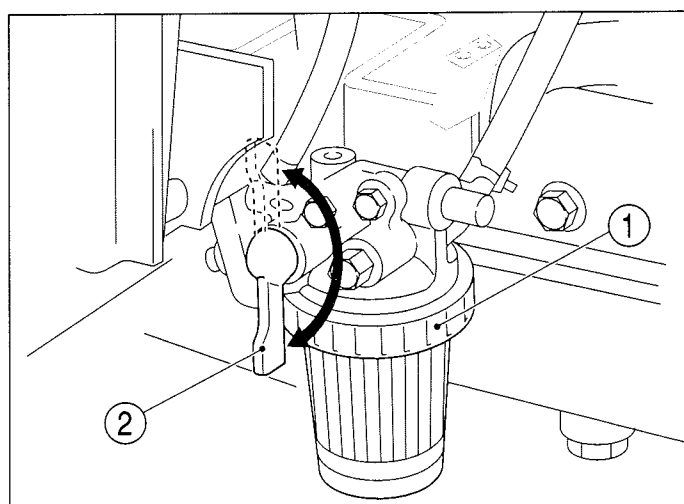

FIG. 88

## TM215F, TM217F & TM223F

FIG. 89: To replace the fuel filter element or clean sediment, turn the fuel valve to the OFF position (top).

Carefully loosen the spanner nut (1) and remove the nut, sediment bowl (2) and "O"-ring (3). Sediment bowl can be cleaned at this time. Pull downward on the filter element (4) and discard. Examine the small "O"-ring (5) in the filter head and replace as necessary. Install new element, pushing upward until seated.

Install sediment bowl "O"-ring and nut. Tighten the nut and wipe up spilled fuel.

### Air-bleeding Procedure

Fuel system should be bled of air after following cases.

- Emptied fuel tank
- Removal of the fuel filter or fuel piping

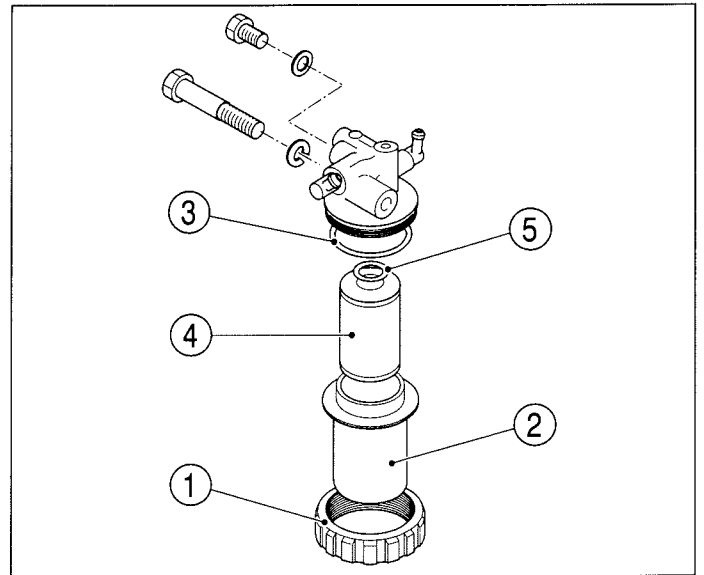

FIG. 89

### FIG. 90 & 91 TM215 & TM217

1. Fill the fuel tank.
2. Turn the fuel cock (1) to "ON."
3. Loosen the air-bleeding screw (2) and let air bubbles out.
4. Loosen the air-bleeding screw (3) of the fuel injection pump and let air bubbles out of the pump.

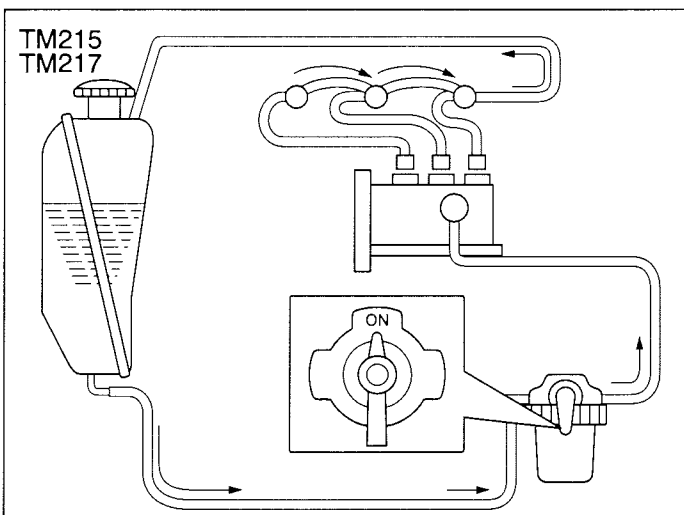

FIG. 90

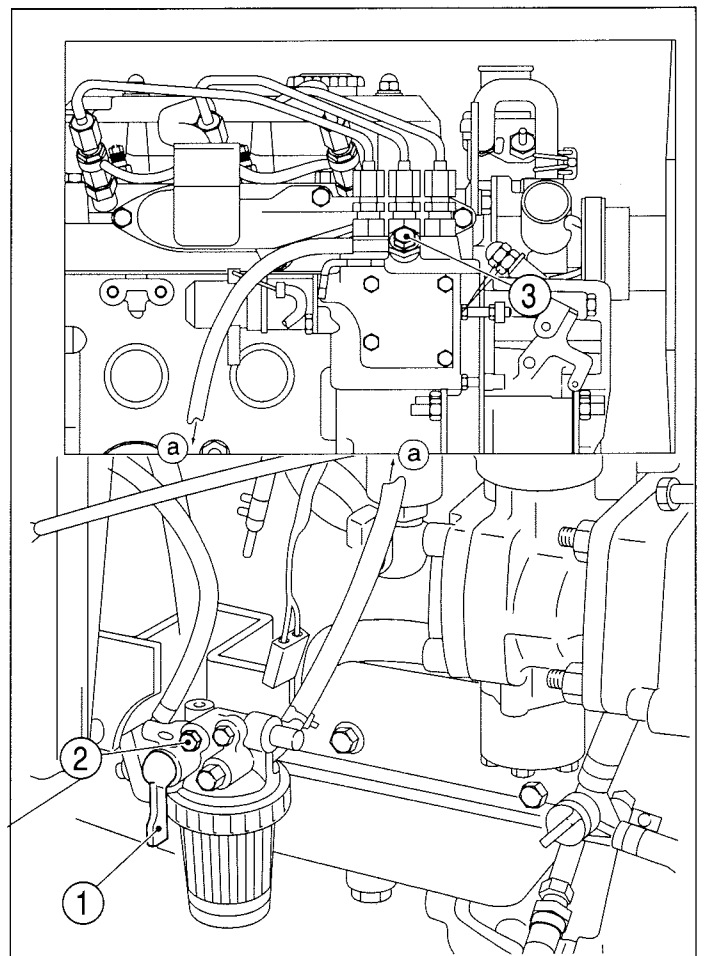

FIG. 91

FIG. 92: TM223

1. Fill the fuel tank.
2. Turn the fuel cock (1) to "ON."
3. Turn the starter switch to the "ON" (Ⓞ) position. Hold the key in this position for about 10 to 15 seconds, and the fuel system is bled automatically.

**NOTE:** Normally, further air-bleeding is not required due to electric fuel pump operating when starter switch in instrument panel is ON. If engine will not start after several attempts, check fuel pump fuses (see Electrical System) and then proceed as necessary.

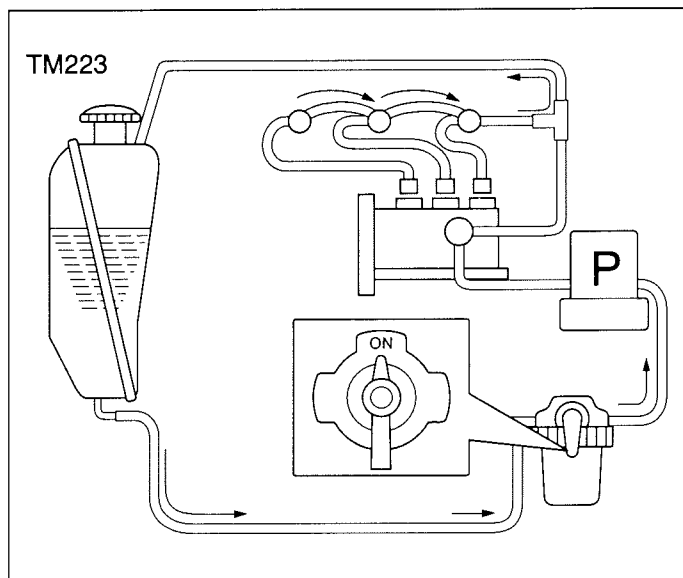

FIG. 92



**CAUTION:** Fuel emitted from loosened injection lines is under high pressure. Keep hands and face away when the engine is cranked. Clean all spilled fuel following air-bleeding procedure(s).

### Throttle Lever

FIG. 93: The throttle lever should remain in the position selected by the operator. Through normal use, friction against the lever may decrease, causing the lever to move out of the selected position. Turn the adjusting nut (1) as required to retain the throttle lever in the position selected.

**NOTE:** Throttle lever friction adjustment nut is reached by removing the steering column cover, and instrument panel.

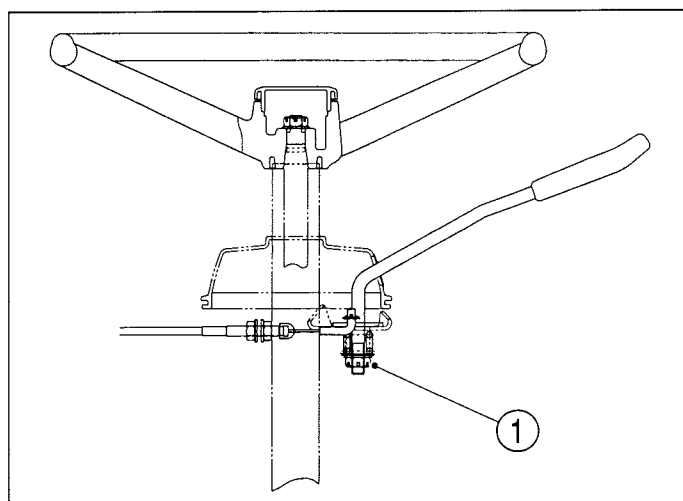

FIG. 93

## **ELECTRICAL SYSTEM**

### **Battery**

FIG. 94: Battery (1) is located under the engine hood in front of the radiator. If the battery requires only minor servicing or charging, it is recommended that the front grille be removed to reach the battery. When the battery is removed, electrolyte inspection or cable cleaning is necessary, the front grille must be removed from the tractor. Keep top of the battery clean and ensure cable connections are clean and tight. Debris on the battery can cause discharge of the battery and be a possible source of fire.



**CAUTION:** *Batteries produce explosive hydrogen when they have charged. Keep all sparks and open flames away from the battery. When necessary to disconnect battery cables, always disconnect the earthed (-) cable first to prevent short circuits. Batteries contain sulfuric acid electrolyte fluid. Wear eye and face protection. If electrolyte comes in contact with skin or clothes, wash immediately. Contact a physician immediately if electrolyte is ingested or gets in eyes.*

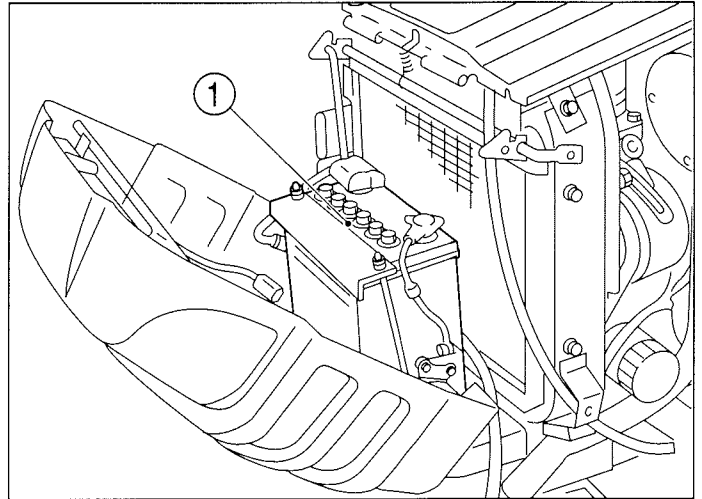

FIG. 94

FIG. 95: Tractors are shipped with the battery installed. If battery replacement should become necessary, disconnect the negative (-) cable (1) first and then remove the positive (+) cable (2). Loosen and remove the battery securing clamp and carefully remove the battery from the tractor.

When installing the battery, the cable (2) connected to the starter solenoid should be connected to the positive (+) battery terminal first then the cable (1) earthed to the tractor frame can be connected to the negative (-) battery terminal.

**NOTE:** *Make sure the replacement battery is of identical size and equal capacity.*

**IMPORTANT:** *Do not reverse battery cable connections as severe electrical system damage will result.*

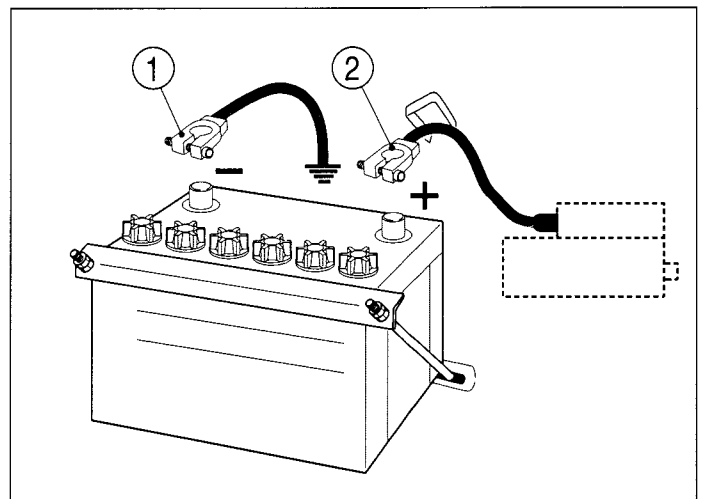

FIG. 95

FIG. 96: Water normally need not be added to the battery as the battery is of maintenance-free type.

However, electrolyte level should be inspected and must be maintained between the upper limit A and lower limit B. DO NOT overfill as electrolyte will spill out and cause corrosion. Add only distilled water to individual "cells," when required.

**IMPORTANT:** *To mix electrolyte and distilled water, either the tractor must be operated to charge the battery or the battery charged externally. Failure to mix will result in a frozen battery at low temperatures.*

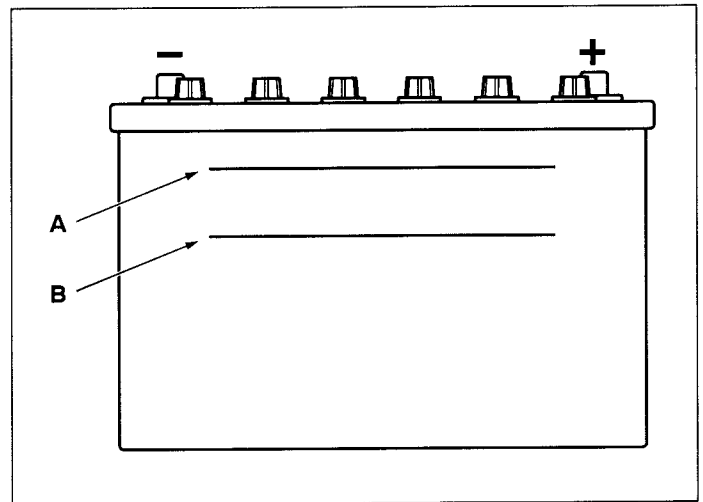

FIG. 96

Should battery performance be questioned, the battery should be removed and recharged from an external source following battery charger instruction. Repeated battery charging or electrolyte usage may be due to a defect in the charging system on the tractor and/or a defective battery.

**NOTE:** *When charging battery from an external source, battery temperature must not exceed 54 °C (125 °F). If overheating occurs, charge rate must be reduced or charging halted.*

### **Safety Switches**

This tractor is equipped with a safety-start system consisting of safety switches and safety relay. To start the tractor:

- Gear shift lever must be in neutral.
- PTO control lever must be in the neutral (OFF) position.
- Mid PTO control lever must be in the neutral (OFF) position.

Wiring/Fuse Arrangement

**CAUTION:** Keep all wiring connections clean and tight. Make sure wiring is correctly secured to prevent damage.

**CAUTION:** DO NOT alter wiring by adding "home-made" extensions or replacements. Doing so can eliminate fuse protection and/or eliminate safety features of the system.

**CAUTION:** The tractor is equipped with negative (-) ground system. Tractor metal parts provide many electrical connections. For this reason, all positive (+) circuits must be insulated to prevent "earthing" or short circuits and prevent possible fire.

**CAUTION:** DO NOT replace any fuse with a fuse of higher amperage rating. DO NOT use wire (or foil) to by-pass fuse protection. Fire can result. If fuses blow repeatedly, examine the electrical system for "earthed" or "shorted" circuits.

|                             |     |        |
|-----------------------------|-----|--------|
| (a) Headlamps               | 12V | 45/40W |
| (b) Front turn signal lamps | 12V | 21W    |
| (c) Front small lamps       | 12V | 5W     |
| (d) Stop lamps              | 12V | 21W    |
| (e) Tail lamps              | 12V | 10W    |
| (f) Rear turn signal lamps  | 12V | 12W    |
| (g) License plate lamp      | 12V | 5W     |

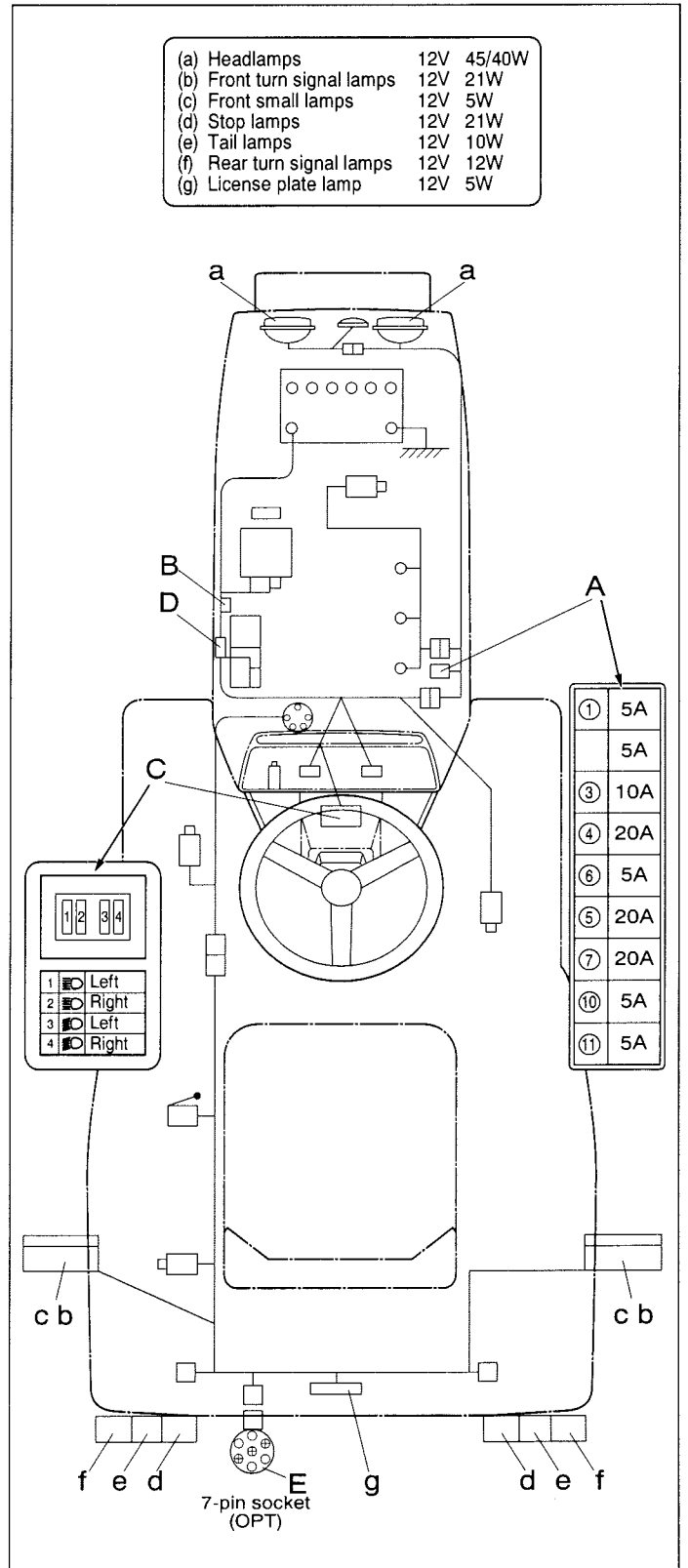

FIG. 97: General layout and location of electrical system components and fuses:

- **Main Fuse Box, A** - Located inside right-hand fan cover.

| Ref. | Amperage | Circuit No. | Function             |
|------|----------|-------------|----------------------|
| 1    | 5A       | 1           | PTO                  |
| 2    | 5A       | —           | —                    |
| 3    | 10A      | 3           | Stop lights          |
| 4    | 20A      | 4           | Direction indicator  |
| 5    | 5A       | 6           | Engine stop relay    |
| 6    | 20A      | 5           | Cab (AC)             |
| 7    | 20A      | 7           | Warning flash lights |
| 8    | 5A       | 10          | Tail light (LH)      |
| 9    | 5A       | 11          | Tail light (RH)      |

\* Work light (rear) is an accessory.

- **Fusible Link B** - A green fusible link is located in the charging circuit. If it fails to function, it will cause the battery to become discharged. If failure occurs, be certain to locate and correct the cause

FIG. 97

of failure before replacing link. A blown fuse will have swollen and/or discolored insulation.

**IMPORTANT:** *Fusible links are of specific gauge-size and length. Use only authorized parts for replacements.*

- **Headlamp Fuse Box C** - located at the rear of the steering column cover.
- **50 Amp. Slow-Blow Fuse D** - is located in the main wiring harness at front of starter. When it burns out there will be no current flow through any of the wiring. If failure occurs be certain to locate and correct the problem prior to installing a new fuse.
- **7-pin Trailer Socket E**

**NOTE:** *A special fuse is used - use only genuine ISEKI parts.*

**WIRING DIAGRAM**

Please refer to the folder bound at the end of this manual.

**CLUTCH FREE-PLAY ADJUSTMENT (TM215/217)**

FIG. 98 & 99: Check clutch pedal free-play regularly and adjust as necessary. Correct clutch pedal free-play A is 20 to 30 mm (7/8") when measured at the end of the pedal (1) as shown.

**NOTE:** *Through use, clutch free-play will be reduced.*

**IMPORTANT:** *Correct free-play must be maintained to reduce wear on the clutch and release bearing, and allow complete disengagement when the pedal is depressed.*

To adjust clutch pedal free-play, locate the linkage under the left foot step, and loosen the lock nut (2). Adjust the turnbuckle (3) on the linkage until free-play

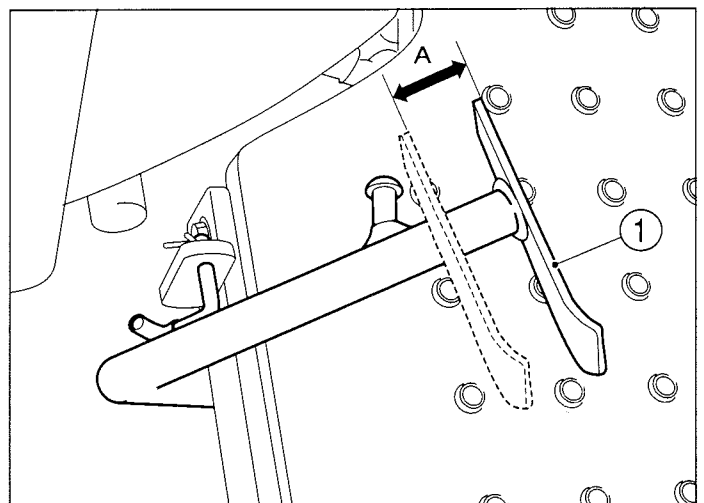

FIG. 98

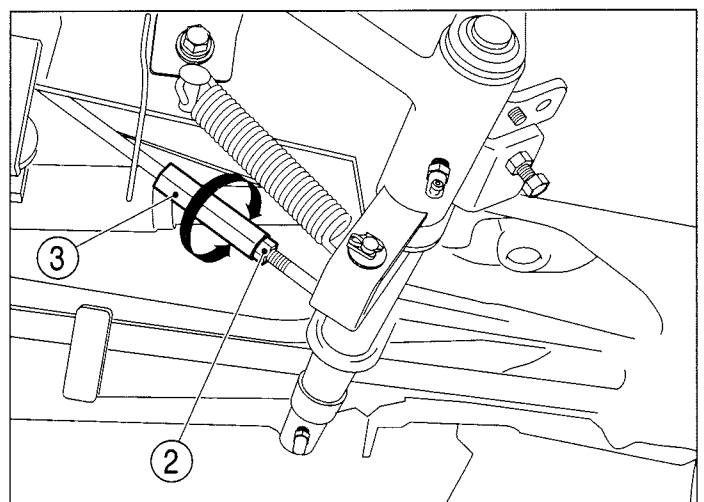

FIG. 99

## TM215F, TM217F & TM223F

is correct. Lengthening the linkage will increase free-play, shortening the linkage will reduce free-play.

Secure by retightening the lock nuts.

### BRAKE FREE-PLAY ADJUSTMENT

FIG. 100 & 101: Unlatch the pedals and check free-play of each brake pedal. Correct free-play A of each individual brake pedal is 20 to 30 mm (7/8" to 1-1/8").

**NOTE:**

- Through use, free-play will increase and brake balance will be affected. Adjust and balance brakes before free-play is excessive.
- HST models do not have individual wheel brakes.

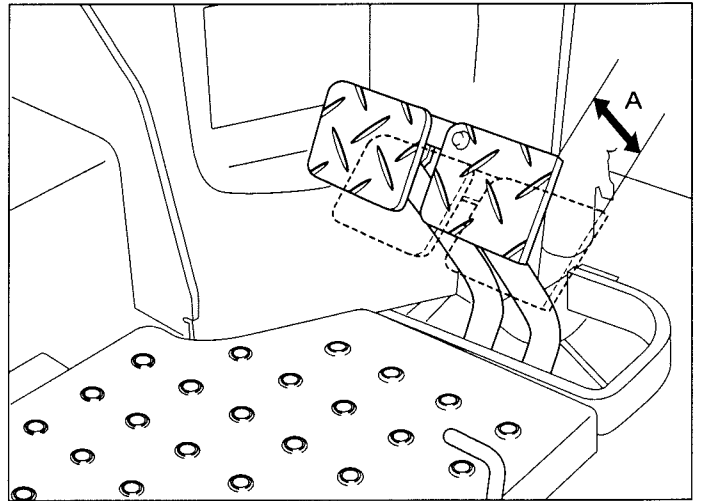

FIG. 100

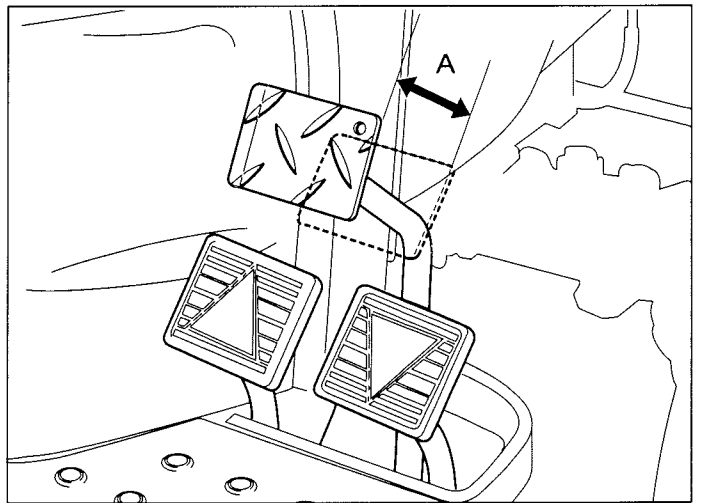

FIG. 101

### Mechanical Transmission

FIG. 102 & 103: Loosen the lock nut (1) (right-hand thread) and lock nut (2) (left-hand thread). Adjust the rod using weld nut (3), so free-play is correct for respective brake pedal.

Repeat procedure for other brake so free-play in pedals is equal. Secure lock nuts against clevis.

When adjustment is complete, latch the pedals together and operate the tractor at low speed. Depress the pedals. If the tractor has tendency to "pull" to one side, slight readjustment of one brake is required.

Make sure the lock nuts are secured when brake adjustment is complete.

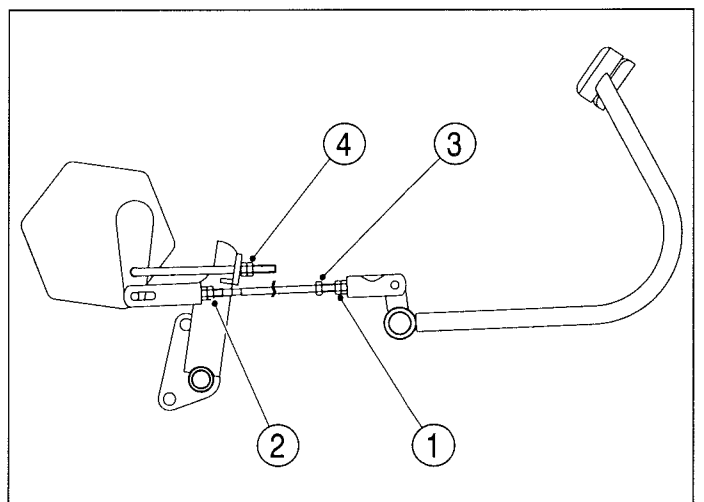

FIG. 102

To adjust brake balance of the parking brakes, loosen

right-hand lock nut (4) or left-hand one (5) and make both brakes evenly effective.

When above adjustment is completed, check operation of parking brakes. Depress the pedals fully and apply parking brakes. It should have brakes locked with the lever approximately in centre of travel. If not, adjust lock nut (6) correctly. Make sure the lock nuts are secured when brake adjustment is completed.



**CAUTION:** *Brakes must be adjusted evenly to permit equal braking action at both rear wheels when brake pedals are latched together.*

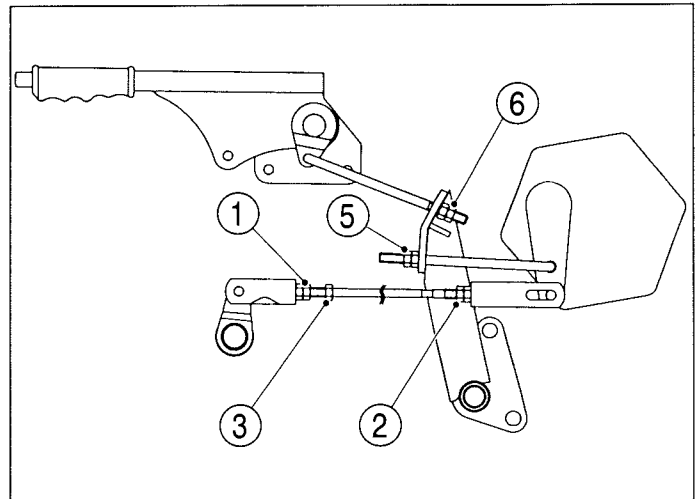

FIG. 103

### Hydrostatic transmission

FIG. 104 & 105: Loosen the lock nut (1) and adjust free play of the brake pedal correctly.

To adjust brake balance, loosen the lock nut (2) (RH) or 3 (LH) and make both brakes evenly effective. When adjustment is complete, secure above lock nuts, and operate the tractor at low speed. Depress the pedal. If the tractor has tendency to “pull” to one side, slight readjustment of one brake is required. When above adjustment is completed, check operation of parking brakes. Depress the pedal fully and apply parking brakes. It should have brakes locked with lever approximately in center of travel. If not, adjust the lock nut (4) correctly. Make sure lock nuts are secured when brake adjustment is completed.

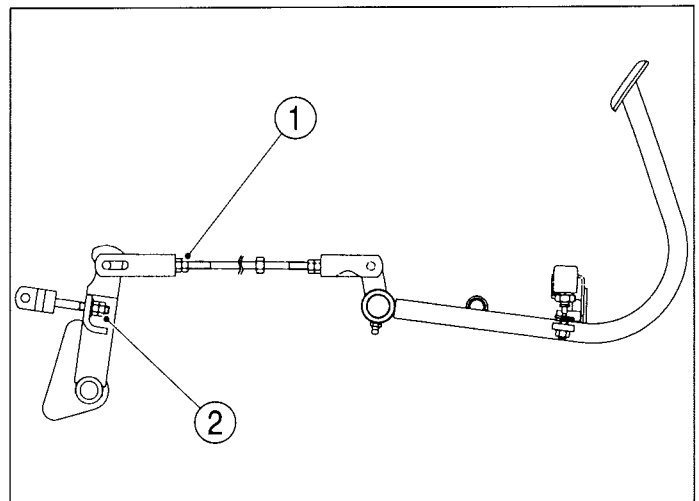

FIG. 104

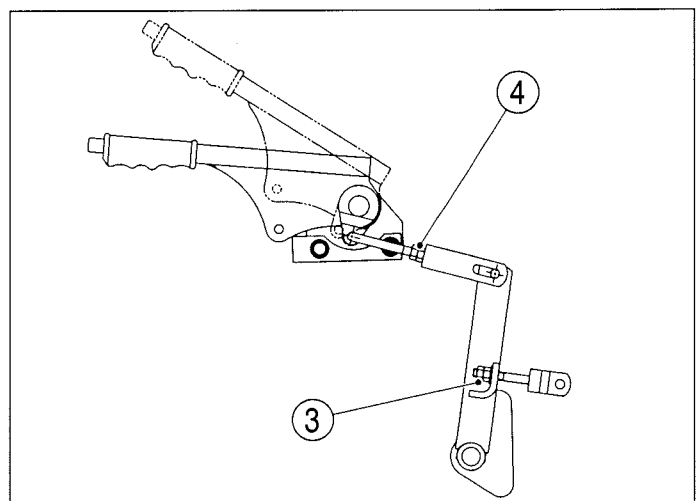

FIG. 105

**TM215F, TM217F & TM223F**

**WHEELS & TYRES**

Examine wheels and tyres periodically for correct inflation pressures, tight wheel bolts, and any physical damage that may be a detriment to tractor operation and operator safety. Correct condition prior to tractor operation.

**Tyre Inflation Pressures**

FIG. 106: Maintaining correct tyre pressure will help insure tyre life. Never exceed the maximum inflation pressure specified on the tyre. If tyres have deep scratches, cuts or punctures, the respective tyre should be repaired or replaced by qualified personnel as soon as possible.

*IMPORTANT: If necessary to replace any tyre(s), ensure original tyre size is used. This is particularly true on 4-WD models to ensure correct amount of front axle overspeed (or "lead") is maintained.*

|       |      |                |         |                        |
|-------|------|----------------|---------|------------------------|
| TM215 | AG   | 5x12 FSLM      | 235 kPa | 2.4 kg/cm <sup>2</sup> |
|       |      | 8x16 FSLW      | 157 kPa | 1.6 kg/cm <sup>2</sup> |
|       | Turf | 20.5x8.00-10PD | 157 kPa | 1.6 kg/cm <sup>2</sup> |
|       |      | 29x12.00-15PD  | 137 kPa | 1.4 kg/cm <sup>2</sup> |
| TM217 | AG   | 5.00x12 FSLMA  | 196 kPa | 2.0 kg/cm <sup>2</sup> |
|       |      | 8x18 FSLH      | 157 kPa | 1.6 kg/cm <sup>2</sup> |
|       | Turf | 20.5x8.00-10PD | 157 kPa | 1.6 kg/cm <sup>2</sup> |
|       |      | 29x12.00-15PD  | 137 kPa | 1.4 kg/cm <sup>2</sup> |
| TM223 | AG   | 5.00x12        | 196 kPa | 2.0 kg/cm <sup>2</sup> |
|       |      | 9.5x16         | 137 kPa | 1.4 kg/cm <sup>2</sup> |
|       | Turf | 23x10.50-12    | 157 kPa | 1.6 kg/cm <sup>2</sup> |
|       |      | 315/75D-15     | 98 kPa  | 1.0 kg/cm <sup>2</sup> |

FIG. 106

**Wheel Bolt Torque**

Periodically check all wheel bolt torques.

Correct bolt torques:

Front Wheel Bolts ..... 102 Nm (75 ft-lbs)

Rear Wheel Bolts ..... 102 Nm (75 ft-lbs)



**CAUTION:** Correct wheel bolt torque must be maintained. Installation of front or mid-mounted implements (ex; loaders, mowers) impose increased loads and require frequent checking of wheel bolts.

**Front Wheel Spacing**

Tread widths may be varied by using the following methods as applicable. Tread widths are measured tyre centre to tyre centre as close to the ground as possible.

**NOTE:** Make certain desired setting is compatible with implements to be used to prevent clearance and interference problems.

FIG. 107: Tyre Tread Widths

|       | AGRICULTURAL |                 | TURF   |
|-------|--------------|-----------------|--------|
|       | A            | B               | C      |
| TM215 | 750 mm       | Not recommended | 870 mm |
| TM217 | 750 mm       | Not recommended | 870 mm |
| TM223 | 750 mm       | Not recommended | 900 mm |

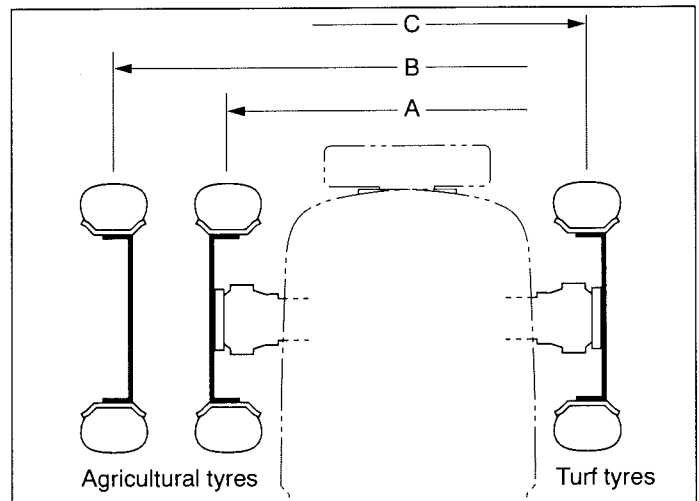

FIG. 107

**Rear Wheel Spacing**

To reverse the entire wheel and tyre assembly - Raise both rear tyres of the tractor. Remove the bolts securing both rear wheel assemblies to the rear axle hubs and switch wheel assemblies to opposite sides of the tractor.

FIG. 108: Tyre Tread Widths

|       | AGRICULTURAL |        | TURF   |
|-------|--------------|--------|--------|
|       | A            | B      | C      |
| TM215 | 770 mm       | 950 mm | 900 mm |
| TM217 | 800 mm       | 910 mm | 900 mm |
| TM223 | 800 mm       | 920 mm | 900 mm |

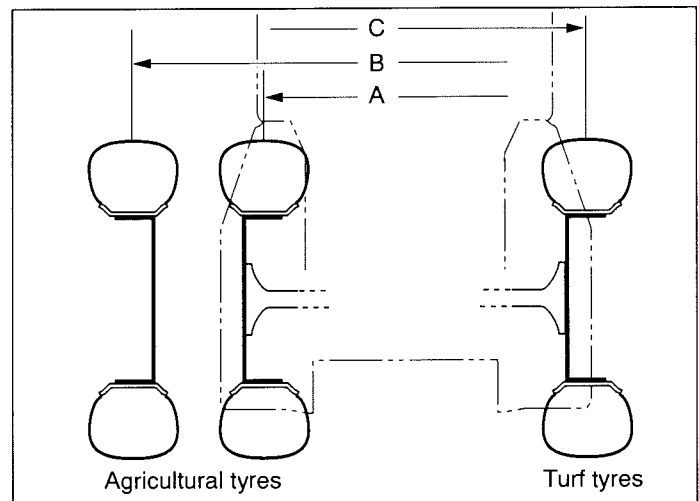

FIG. 108

**CAUTION:** *Rear wheels are heavy. Use care when moving them. Make sure the tractor is blocked securely. Tighten all wheel bolts securely and recheck after short period of operation.*

**NOTE:** *Agricultural lug-type tyres must always be installed so when viewed from the rear, the "V" pattern of the tread points upward.*

**Steering Free-Play**

FIG. 109: Steering system should be checked for excessive looseness as indicated by steering wheel free-play. Maximum free-play is approximately 30 to 60 mm (1-1/4" to 2-3/8") when measured at the outside of steering wheel rim as shown at "X". Excessive free-play can be caused by :

- Loose or worn ball joints
- Worn or damaged steering column shaft/universal joints
- Worn or damaged power steering unit (if equipped)

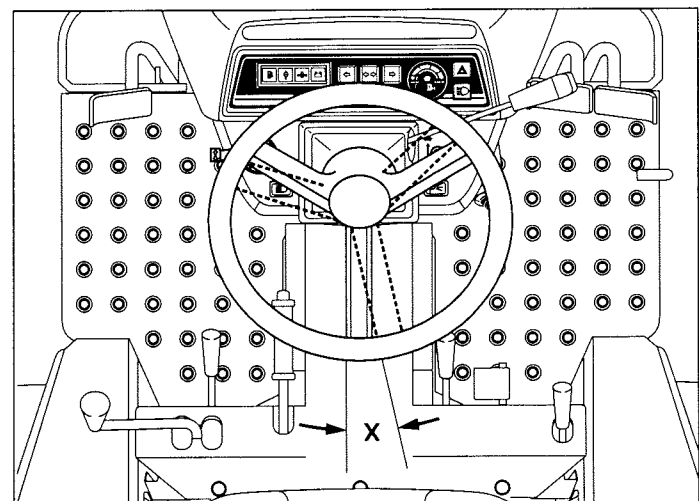

FIG. 109

## TM215F, TM217F & TM223F



**CAUTION:** Excessive steering free-play must be corrected before use. Contact your ISEKI dealer.

### Front Axle End-Float

FIG. 110: Fore and aft play of the front axle (1) in its supports should be 0.1 to 0.3 mm (0.004-0.012"). End-float is measured with axle raised off the ground.

Loosen the lock nut (2) and turn the adjusting bolt (3) as needed to achieve correct measurement. Tighten the lock nut.

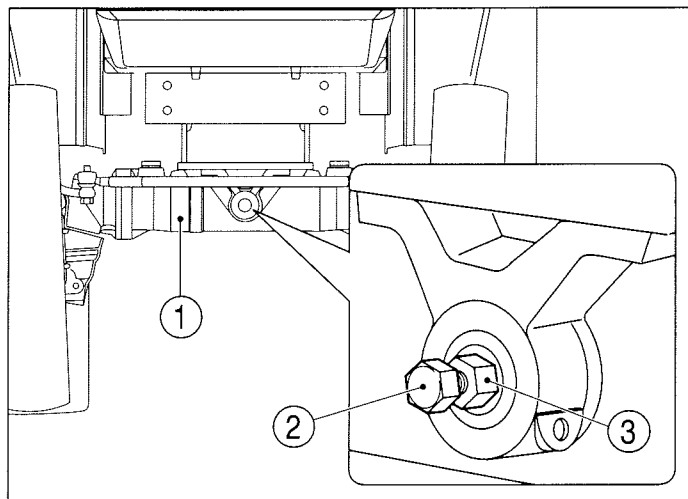

FIG. 110

**NOTE:** Excessive end-float will cause noise. This noise will be more pronounced when using 4WD.

### CLUTCH HOUSING PLUG (TM215/217)

FIG. 111: Pipe plug (1) should be removed from the bottom of the clutch housing once a year or when clutch slipping is apparent. Any oil leakage from the engine rear crankshaft seal and/or transmission input shaft will be indicated by oil draining through the hole. Contact your ISEKI dealer if oil leakage is evident.

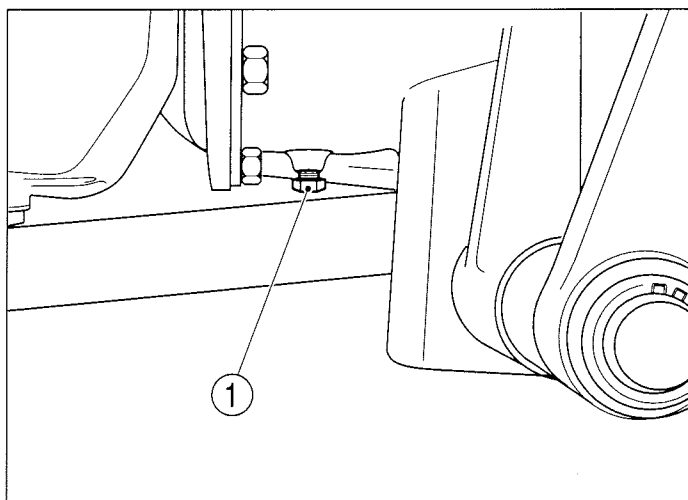

FIG. 111

### TORQUE CHART

FIG. 112: All fasteners should be tightened in accordance with the torque chart unless a specific torque value is called out in relevant maintenance information.

### STORAGE

If the tractor is to be stored for extended periods such as off-season non-use, certain measures should be taken for its preservation during such periods. These measures will vary according to geographical area and storage season.

1. Replace engine oil and filter. Operate at low idle five minutes to lubricate parts.
2. Lubricate all grease fittings and lightly oil control linkage pivots.
3. Detach implements.
4. Store the tractor in an enclosed area, if possible,

| kgf-m<br>(ft-lbs) | 4T bolts<br>and nuts           | 7T bolts                       | 7T nuts;<br>9T bolts<br>and nuts |
|-------------------|--------------------------------|--------------------------------|----------------------------------|
| M5                | 0.3 - 0.4<br>(2.2 - 3.0)       | 0.5 - 0.6<br>(3.6 - 4.3)       | 0.6 - 0.7<br>(4.3 - 5.1)         |
| M6                | 0.6 - 0.8<br>(4.3 - 5.8)       | 0.9 - 1.1<br>(6.5 - 8.0)       | 1.0 - 1.3<br>(7.2 - 9.4)         |
| M8                | 1.3 - 1.8<br>(9.4 - 13.0)      | 2.0 - 2.7<br>(14.5 - 19.5)     | 2.5 - 3.5<br>(18.1 - 25.3)       |
| M10               | 2.0 - 3.0<br>(14.5 - 21.7)     | 4.5 - 5.5<br>(32.6 - 39.8)     | 5.5 - 7.0<br>(39.8 - 50.6)       |
| M12               | 5.0 - 6.0<br>(36.2 - 43.4)     | 7.5 - 9.0<br>(54.3 - 65.1)     | 9.0 - 11.0<br>(65.1 - 79.6)      |
| M14               | 7.0 - 8.0<br>(50.6 - 57.9)     | 10.0 - 12.0<br>(72.3 - 86.8)   | 13.0 - 15.0<br>(94.0 - 108.5)    |
| M16               | 10.0 - 12.0<br>(72.3 - 86.8)   | 12.0 - 14.0<br>(86.8 - 101.3)  | 16.0 - 18.0<br>(121.7 - 130.2)   |
| M18               | 12.0 - 14.0<br>(86.8 - 101.3)  | 16.0 - 18.0<br>(115.7 - 130.2) | 20.0 - 24.0<br>(144.7 - 173.6)   |
| M20               | 15.0 - 17.0<br>(108.5 - 123.0) | 19.0 - 21.0<br>(137.4 - 151.9) | 24.0 - 26.0<br>(173.6 - 188.1)   |

FIG. 112

for protection from weather.

5. Block up the tractor to remove weight from tyres and to protect tyres from oily or damp floor.

FIG. 113:

6. Raise and lock the three-point lift linkage in up position by turning the lowering rate control handle (1) fully clockwise.

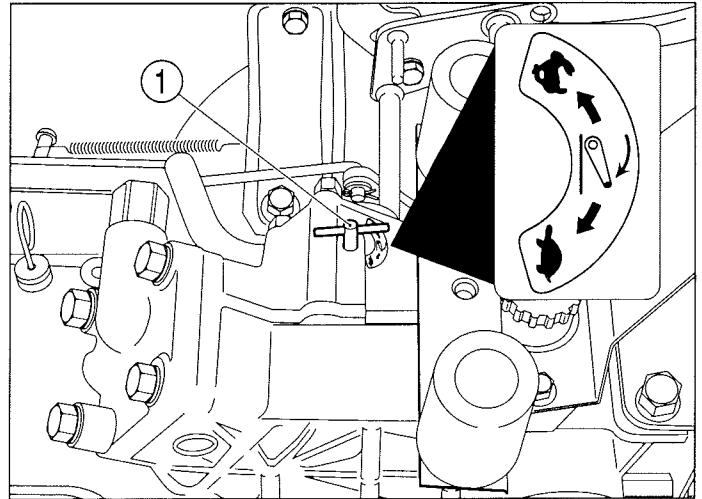

FIG. 113

FIG. 114:

7. Fill the fuel tank to prevent condensation from forming on inside of the tank. Turn the filter valve (2) to OFF position (handle to upside).
8. Remove the battery and store in cool dry place.
9. If the tractor is stored during cold weather season insure that anti-freeze is adequate. Alternatively, the radiator and engine block may be drained.
10. Check with your diesel fuel supplier on the availability of a diesel fuel additive to place in the fuel system during storage period.
11. If the tractor cannot be placed in an enclosed area place it under some sort of cover and cover exhaust pipe to prevent entrance of rain or snow.

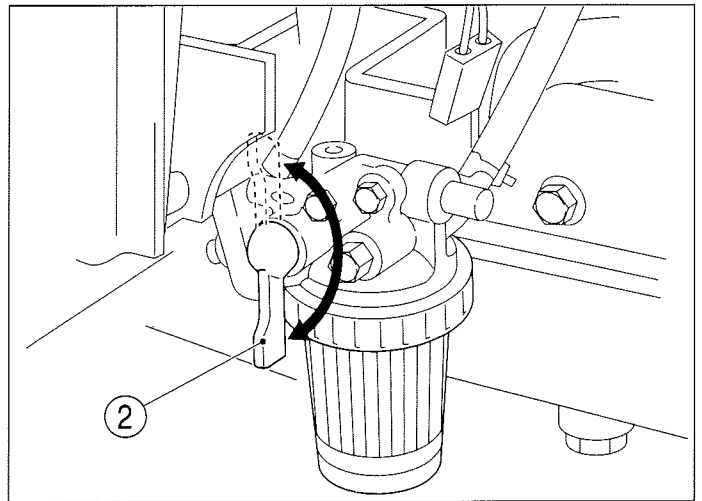

FIG. 114

FIG. 115:

12. Depress the clutch pedal and secure in the disengaged position with the hook (3). (TM215/217)

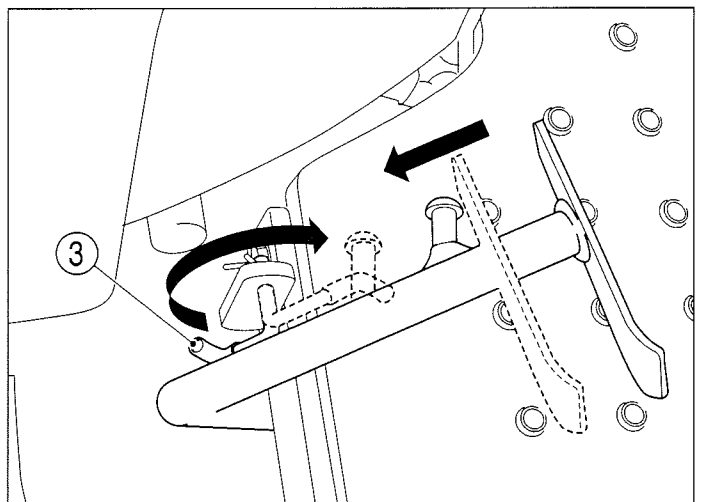

FIG. 115

*NOTE: This is to prevent clutch seizure during long periods of tractor storage.*

13. Touch-up scratches with paint.

At the end of storage period: Perform appropriate lubrication and maintenance before placing the tractor back in service. See “Lubrication and Maintenance” section.

- Conduct full prestart inspection. Make sure all controls operate correctly.
- Allow the engine to idle approximately 30 minutes. Check for leaks and repair as required.

## TROUBLESHOOTING

### Engine

| Problem   | Possible Cause  | Remedy   |
|---|---|--|
| Starter motor does not operate with key turned to START | <ul style="list-style-type: none"> <li>• Shift lever not in neutral</li> <li>• PTO shift lever engaged</li> <li>• Mid PTO shift lever engaged</li> <li>• Broken safety switch</li> <li>• Discharged battery</li> <li>• Loose or dirty terminals</li> <li>• Broken main switch</li> <li>• Broken starter</li> <li>• PTO switch is not in off.</li> </ul> | Place lever in neutral<br>Place lever in neutral<br>Place lever in neutral<br>Consult your Dealer<br>Charge battery<br>Clean and retighten securely<br>Consult your Dealer<br>Consult your Dealer<br>Consult your Dealer |
| Starter motor operates but not at full speed            | <ul style="list-style-type: none"> <li>• Discharged battery</li> <li>• Loose or dirty terminals</li> <li>• Defective ground</li> <li>• Improper oil viscosity</li> <li>• Defective engine</li> </ul>  | Charge battery<br>Clean and retighten securely<br>Clean and tighten starter mounting<br>Replace with oil of proper viscosity<br>Consult your Dealer  |
| Starter motor operates but engine does not start        | <ul style="list-style-type: none"> <li>• Electric fuel control not operating</li> <li>• Air in fuel system</li> <li>• Clogged fuel filter</li> <li>• Fuel is not being supplied</li> <li>• Incorrect preheating procedure</li> <li>• Defective engine</li> </ul>  | Consult your Dealer<br>Air-bleed fuel system<br>Clean filter<br>Check fuel level, open fuel valve<br>Increase use of glow plugs<br>Consult your Dealer   |
| Irregular engine running                                | <ul style="list-style-type: none"> <li>• Air in fuel system</li> <li>• Clogged fuel filter</li> <li>• Clogged fuel injectors</li> <li>• Fuel-line is leaking air</li> <br/> <li>• Fuel injection pump timing</li> <li>• Defective engine</li> </ul>   | Air-bleed fuel system<br>Clean filter<br>Consult your Dealer<br>Retighten clamps, replace defective pipes<br>Consult your Dealer<br>Consult your Dealer  |
| When decelerated, engine stops                          | <ul style="list-style-type: none"> <li>• Incorrect low idle setting</li> <li>• Malfunctioning fuel injection pump</li> <li>• Improper valve clearance</li> <li>• Defective fuel injectors</li> </ul>  | Consult your Dealer<br>Consult your Dealer<br>Consult your Dealer<br>Consult your Dealer   |
| Engine over-speeds                                      | <ul style="list-style-type: none"> <li>• Defective governor</li> <li>• Incorrect high speed setting</li> </ul>  | Consult your Dealer<br>Consult your Dealer   |

## TROUBLESHOOTING

| Problem                                      | Possible Cause  | Remedy  |
|--|---|---|
| Engine over-speeds                           | <ul style="list-style-type: none"> <li>• Engine oil is getting into combustion chambers</li> </ul>  | Consult your Dealer   |
| Engine stops unexpectedly during operation   | <ul style="list-style-type: none"> <li>• Insufficient fuel supply</li> <li>• Defective fuel injectors</li> <li>• Defective fuel injection pump</li> <li>• Engine seizure due to low or poor oil</li> <li>• Electric fuel pump not operating</li> </ul>  | Top up fuel and air-bleed fuel system<br>Consult your Dealer<br>Consult your Dealer.<br><i>(If engine can be turned by pulling fan belt, fuel system is most probable causes)</i><br>Replace fuse |
| Engine overheats                             | <ul style="list-style-type: none"> <li>• Insufficient coolant</li> <li>• Broken or loose fan belt</li> <li>• Clogged grille, radiator screens</li> <li>• Clogged radiator fins</li> <li>• Defective thermostat</li> <li>• Insufficient engine oil</li> </ul>  | Top up coolant<br>Adjust belt tension or replace<br>Clean<br>Clean<br>Replace<br>Inspect oil level and replenish if necessary   |
| Exhaust fumes are white                      | <ul style="list-style-type: none"> <li>• Clogged air cleaner</li> <li>• High engine oil level</li> <li>• Insufficient fuel delivery</li> <li>• Cold-running engine</li> </ul>   | Clean or replace element(s)<br>Inspect oil level and correct<br>Consult your Dealer<br>Allow to warm check thermostat   |
| Exhaust fumes are too black                  | <ul style="list-style-type: none"> <li>• Poor fuel</li> <li>• Excessive fuel delivery</li> <li>• Insufficient fuel injector pressure</li> <li>• Insufficient combustion air</li> </ul>  | Replace with better grade<br>Consult your Dealer<br>Consult your Dealer<br>Check, clean or replace air filter   |
| Poor engine output                           | <ul style="list-style-type: none"> <li>• Seized fuel injectors and/or carbon deposit</li> <li>• Insufficient compression or leaking valves</li> <li>• Incorrect valve clearances</li> <li>• Incorrect fuel injection timing</li> <li>• Insufficient fuel supply</li> <li>• Clogged air cleaner</li> </ul> | Consult your Dealer<br><br>Consult your Dealer<br><br>Consult your Dealer<br>Consult your Dealer<br>Check fuel system<br>Clean or replace element(s)  |
| Oil pressure monitor is lit during operation | <ul style="list-style-type: none"> <li>• Insufficient engine oil</li> <li>• Too low oil viscosity</li> <li>• Defective pressure switch</li> <li>• Clogged oil filter</li> <li>• Defective oil pump</li> </ul>   | Replenish<br>Replace with oil of proper viscosity<br>Replace<br>Replace element cartridge<br>Consult your Dealer  |

**TM215F, TM217F & TM223**

| Problem                                  | Possible Cause  | Remedy  |
|--|---|---|
| Charging monitor is lit during operation | <ul style="list-style-type: none"> <li>• Defective wiring short circuit, poor ground, etc.</li> <li>• Defective alternator</li> <li>• Defective regulator</li> <li>• Low electrolyte level or defective battery</li> <li>• Loose or damaged fan belt</li> </ul> | Correct loose or dirty terminals,<br>Consult your Dealer<br>Consult your Dealer<br>Correct electrolyte level or replace battery<br>Adjust belt tension or replace |

**Clutch (TM215 & TM217)**

| Problem                | Possible Cause   | Remedy   |
|------------------------|--|--|
| Clutch slips           | <ul style="list-style-type: none"> <li>• Poor clutch pedal adjustment</li> <li>• Worn or burnt clutch lining</li> <li>• Engine, transmission oil leak</li> </ul> | Adjust free-play<br>Consult your Dealer<br>Consult your Dealer |
| Clutch won't disengage | <ul style="list-style-type: none"> <li>• Poor pedal adjustment</li> <li>• Seized clutch lining</li> <li>• Transmission shafts seized</li> </ul>                  | Adjust free-play<br>Consult your Dealer<br>Consult your Dealer |

**Brakes**

| Problem  | Possible Cause   | Remedy  |
|--|--|---|
| Brakes do not work well or not balanced with each other when applied | <ul style="list-style-type: none"> <li>• Too much free play of pedals</li> <li>• Worn or seized linings</li> <li>• Unequal pedal adjustment</li> </ul> | Adjust free-play<br>Consult your Dealer<br>Correct so both pedals are equal |

**Hydraulic System**

| Problem                   | Possible Cause  | Remedy   |
|---------------------------|---|--|
| Insufficient oil pressure | <ul style="list-style-type: none"> <li>• Low engine speed</li> <li>• Low transmission oil</li> <li>• Intake piping is sucking air</li> <li>• Clogged oil filter(s)</li> <li>• Defective hydraulic oil pump</li> <li>• Defective control valve</li> <li>• Broken cylinder</li> </ul> | Increases speed<br>Fill to specified level<br>Retighten clamps or replace cracked pipes and defective O-rings<br>Clean or replace<br>Consult your Dealer<br>Consult your Dealer<br>Consult your Dealer |

| Problem  | Possible Cause   | Remedy   |
|--|--|--|
| Leaking piping   | <ul style="list-style-type: none"> <li>• Loose joints</li> <li>• Cracked pipes</li> </ul>  | Retighten<br>Replace pipes, O-rings  |
| With control lever in RAISE position, relief valve blows | <ul style="list-style-type: none"> <li>• Poorly adjusted rod on position control lever</li> </ul>  | Correct rod adjustment   |
| Three-point hitch does not lower                         | <ul style="list-style-type: none"> <li>• Locked lowering rate control handle</li> <li>• Defective control valve</li> <li>• Broken cylinder</li> <li>• Seized lift shaft bearing</li> </ul> | Turn counter clockwise to LOWERING position<br>Consult your Dealer<br>Consult your Dealer<br>Consult your Dealer |

**Steering System**

| Problem  | Possible Cause  | Remedy  |
|--|---|---|
| Steering wheel is hard to turn or turns in one direction | <ul style="list-style-type: none"> <li>• Poorly installed steering column</li> <li>• Air in steering hydraulic system</li> <li>• Clogged suction filter</li> <li>• Improper toe-in</li> <li>• Different front tyre inflation</li> <li>• Loose steering or ball joints</li> <li>• Defective steering units pump</li> </ul> | Correct<br>Air-bleed steering system<br>Remove and clean<br>Correct<br>Inflate both tyres to same specified pressure<br>Retighten or replace defective parts<br>Consult your Dealer |
| Steering wheel has too much free-play                    | <ul style="list-style-type: none"> <li>• Worn steering column</li> <li>• Loose ball joints</li> <li>• Defective steering unit</li> </ul>  | Consult your Dealer<br>Retighten<br>Consult your Dealer   |

**Electrical System**

| Problem                   | Possible Cause  | Remedy  |
|---------------------------|---|---|
| Battery cannot be charged | <ul style="list-style-type: none"> <li>• Blown fuse</li> <li>• Blown fusible link</li> <li>• Defective wiring</li> <li>• Loose or damaged fan belt</li> <li>• Defective battery corrosion, or electrolyte level</li> <li>• Defective alternator</li> <li>• Defective regulator</li> </ul> | Check fuse and replace<br>Check wiring and replace link<br>Correct loose, dirty terminal, short circuit, poor ground, etc.<br>Give belt proper tension or replace<br>Correct loose terminal connection,<br><br>Consult your Dealer<br>Consult your Dealer |

**TM215F, TM217F & TM223**

| Problem                              | Possible Cause   | Remedy   |
|--------------------------------------|--|--|
| Head lamps are dim                   | <ul style="list-style-type: none"><li>• Discharged battery</li><li>• Poor connections</li></ul>  | Charge battery,<br>check charging system<br>Check ground points and<br>terminals. Clean and tighten  |
| Particular function will not operate | <ul style="list-style-type: none"><li>• Burnt bulb (as applicable)</li><li>• Blown fuse</li><li>• Blown fusible, link</li><li>• Poor contact</li><br/><li>• Defective switch</li></ul> | Replace<br>Check fuse and replace<br>Check wiring and replace<br>Inspect ground points and<br>terminals. Clean if necessary<br>Replace as required |

# SPECIFICATIONS

## SPECIFICATIONS

|                  |                              |                                       |       |
|------------------|------------------------------|---------------------------------------|-------|
| Models .....     | TM215 .....                  | TM217 .....                           | TM223 |
| Sub-models ..... | F ..... FMU ... FHU ... FHMU | F ..... FU ..... FMU ... FHU ... FHMU | FHSM  |

### Engine

|   |                                    |               |           |
|---|------------------------------------|---------------|-----------|
| Make .....  | ISEKI Diesel                       |               |           |
| Model .....                                       | E393 .....                         | E3100 .....   | E3100     |
| Type .....  | Indirect injection, overhead valve |               |           |
| Displacement .....                                | 928 cc .....                       | 1006 cc ..... | 1123 cc   |
| Number of cylinders .....                         | 3                                  |               |           |
| Bore .....  | 74 mm .....                        | 74 mm .....   | 78.2 mm   |
| Stroke .....                                      | 72 mm .....                        | 78 mm .....   | 78.0 mm   |
| Engine horsepower (gross)@ engine rpm .....       | 15.5/2500 .....                    | 17/2500 ..... | 22.5/2800 |
| PTO horsepower (estimate) .....                   | 13.5 .....                         | 13 .....      | 15 .....  |
| Firing order .....                                | 1 – 3 – 2                          |               |           |
| Compression ratio .....                           | 22.5:1                             |               |           |
| Low idle speed .....                              | 950 rpm                            |               |           |
| High idle speed .....                             | 2750 rpm .....                     |               | 3050 rpm  |
| Valve clearance (cold) – intake and exhaust ..... | 0.25 mm                            |               |           |
| Air cleaner .....                                 | Single – dry element               |               |           |
| Engine cooling .....                              | Liquid, forced circulation         |               |           |
| Cold starting .....                               | Glow plugs (3)                     |               |           |

### Transmission

|                       |                                 |                |             |                 |            |                 |           |
|-----------------------|---------------------------------|----------------|-------------|-----------------|------------|-----------------|-----------|
| Primary .....         | F3/R1 .....                     | Infinite ..... | F3/R1 ..... | Infinite .....  | Infinite   |                 |           |
| Range .....           | 2                               |                |             |                 |            |                 |           |
| Gear selections ..... | F6/R2 .....                     | F2/R2 .....    | F6/R2 ..... | F2/R2 .....     | F2/R2      |                 |           |
| Clutch .....          | Dry single disc (Dia: 194 mm)   |                |             |                 |            |                 |           |
| Brakes .....          | Mechanically actuated dry shoes |                |             |                 |            |                 |           |
| Speed range (km/h)    | Forward                         | 1 .....        | 1.2 .....   | 0 to 8.4 .....  | 1.2 .....  | 0 to 8.8 .....  | 0 to 9.3  |
|                       |                                 | 2 .....        | 2.1 .....   | 0 to 19.5 ..... | 2.3 .....  | 0 to 20.6 ..... | 0 to 21.6 |
|                       |                                 | 3 .....        | 3.5 .....   | — .....         | 3.7 .....  | — .....         | —         |
|                       |                                 | 4 .....        | 5.9 .....   | — .....         | 6.2 .....  | — .....         | —         |
|                       |                                 | 5 .....        | 10.6 .....  | — .....         | 11.3 ..... | — .....         | —         |
|                       |                                 | 6 .....        | 17.4 .....  | — .....         | 18.5 ..... | — .....         | —         |
|                       | Reverse                         | 1 .....        | 1.9 .....   | 0 to 5.9 .....  | 2.0 .....  | 0 to 6.2 .....  | 0 to 7.0  |
|                       |                                 | 2 .....        | 9.5 .....   | 0 to 13.7 ..... | 10.1 ..... | 0 to 14.5 ..... | 0 to 16.2 |

### Power take-off (PTO)

|                                 |  |                    |
|---------------------------------|--|--------------------|
| Control .....                   | Lever and pedal .....                  | Lever and switch   |
| Rear PTO shaft .....            | 35 mm (1.375 in) diameter – six spline |                    |
| Output .....                    | Clockwise rotation                     |                    |
| Speeds @ engine rpm .....       | 540 @ 2308 .....                       | 540 @ 2398 .....   |
|                                 | 540 @ 2308 .....                       | 540 @ 2398 .....   |
| Mid PTO (accessory) shaft ..... | 25 mm (1 in) diameter – fifteen spline |                    |
|                                 | Output .....                           | Clockwise rotation |
| Speeds @ engine rpm .....       | 2000 @ 2446 .....                      | 2000 @ 2400 .....  |
|                                 | 2000 @ 2446 .....                      | 2000 @ 2400 .....  |

### Hydraulics

|                                       |   |                              |
|---------------------------------------|---|------------------------------|
| Main hydraulic system                 |   |                              |
| Pump .....                            | Gear pump (Open centre)                     |                              |
| Output – maximum .....                | 18.0 litres/min .....                       | 20 litres/min                |
| Pressure – relief valve setting ..... | 140 kgf/cm <sup>2</sup>                     |                              |
| Rear linkage type .....               |   |                              |
| Control .....                         | Three-point hitch                           |                              |
| Control .....                         | Operated by single ‘position’ control lever |                              |
| Lift capacity .....                   | 480 kg measured at link ends .....          | 550 kg measured at link ends |

## TM215F, TM217F & TM223

|                                       |                                    |                                      |       |
|---------------------------------------|------------------------------------|--------------------------------------|-------|
| Models .....                          | TM215 .....                        | TM217 .....                          | TM223 |
| Sub-models .....                      | F..... FMU ... FHU ... FHMU        | F..... FU ..... FMU ... FHU ... FHMU | FHSM  |
| Steering system type .....            | Manual/ Hydro-power (Option) ..... | Hydro-power                          |       |
| Pump .....                            | Gear/ Flow divider                 |                                      |       |
| Output – maximum .....                | 5.5 litres/min .....               | 10 litres/min                        |       |
| Pressure – relief valve setting ..... | 105 kfg/cm <sup>3</sup>            |                                      |       |

### Electrical system

|                                  |   |         |
|----------------------------------|---|---------|
| System voltage .....             | 12 volt - negative (-) ground             |         |
| Battery cca @ - 18°C (0°F) ..... | 325 cca .....                             | 435 cca |
| Charging .....                   | 40 amp alternator with internal regulator |         |

### Capacities

|   |  |            |
|---|--|------------|
| Engine crankcase with filter .....          | 2.7 litres   |            |
| Transmission and differential housing ..... | 13.5 ..... 14.0 ..... 15.0 ..... 15.0 ..... 13.5 ..... 14.0 ..... 14.0 ..... 15.0 ..... 15.0 ..... | 14.0       |
| (including hydraulics) (litres)             |  |            |
| Fuel tank .....                             | 13.5 litres .....  | 23 litres  |
| Cooling system .....                        | 5.1 litres .....   | 7.1 litres |
| Front axle - four-wheel drive .....         | 2.7 litres   |            |

### Track setting

#### Front four-wheel drive

|   |              |        |
|---|--------------|--------|
| Agricultural tyres (dished in only) ..... | 750 mm       |        |
| Turf tyres (dished in only) .....         | 870 mm ..... | 900 mm |

#### Rear four-wheel drive

|  |                     |                     |               |
|--|---------------------|---------------------|---------------|
| Agricultural tyres (adjustable wheels) ..... | 770 to 950 mm ..... | 800 to 910 mm ..... | 800 to 920 mm |
| Turf tyres (dished in only) .....            | 900 mm              |                     |               |

### Maximum axle loading

|  |        |
|--|--------|
| Front four-wheel drive - both models ..... | 650 kg |
| Rear axle - both models .....              | 750 kg |

### Tyre size

|                         |                    |                 |           |
|-------------------------|--------------------|-----------------|-----------|
| Front                   |                    |                 |           |
| Agricultural tyre ..... | 5 – 12 .....       | 5.00 – 12 ..... | 5.00 – 12 |
| Turf tyre .....         | 20.5×8.00-10 ..... | 23.0×10.5-12    |           |
| Rear                    |                    |                 |           |
| Agricultural tyre ..... | 8 – 16 .....       | 8-18 .....      | 9.5-16    |
| Turf tyre .....         | 29×12.00-15 .....  | 31.5/75D-15     |           |

**GENERAL DIMENSIONS**

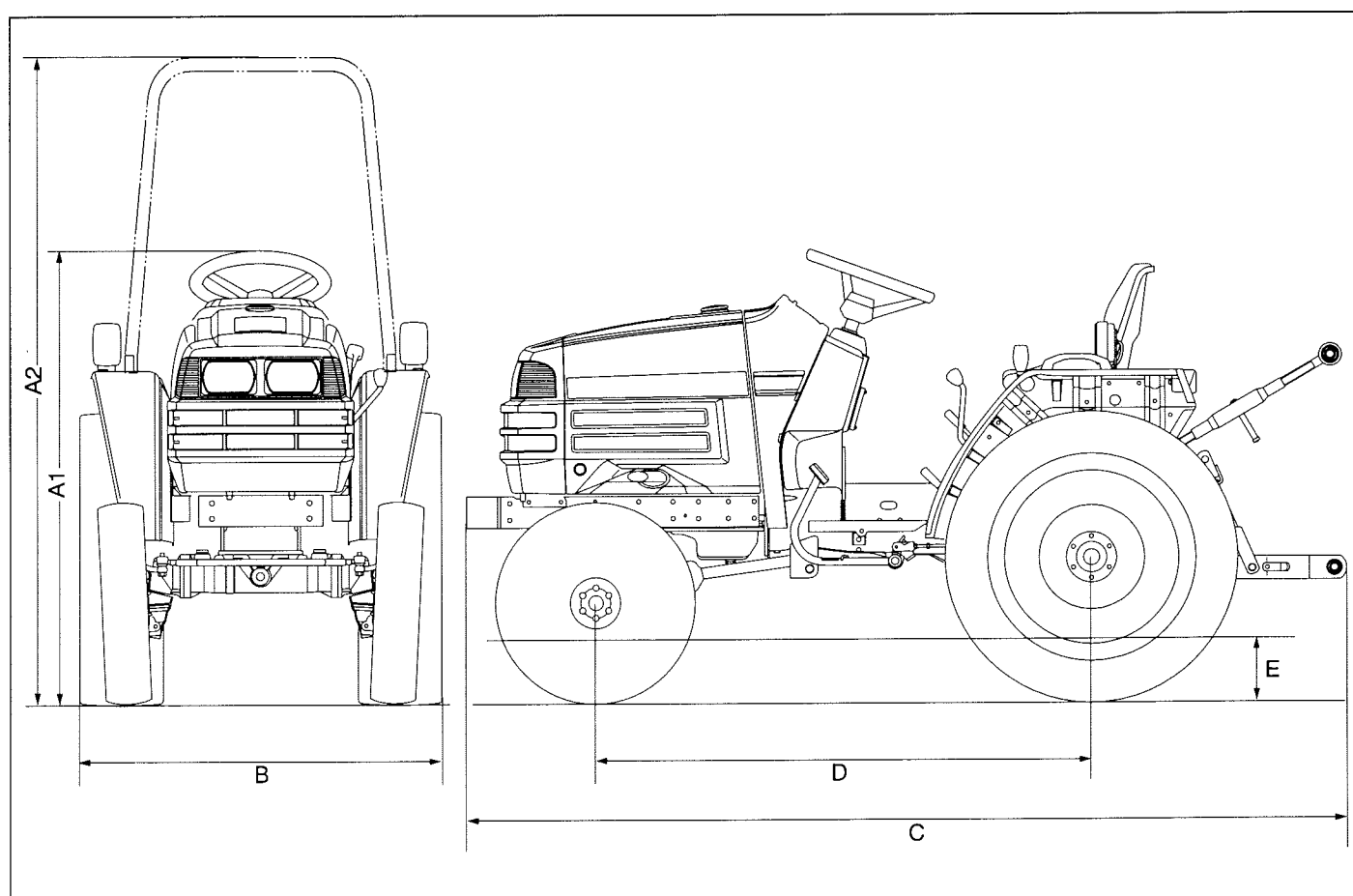

**FIG. 116**

|                  |                             |                                      |       |
|------------------|-----------------------------|--------------------------------------|-------|
| Models .....     | TM215 .....                 | TM217 .....                          | TM223 |
| Sub-models ..... | F..... FMU ... FHU ... FHMU | F..... FU ..... FMU ... FHU ... FHMU | FHSM  |

**Agricultural tyres/trurf tyres**

|                                      |  |                              |                       |                 |
|--------------------------------------|--|------------------------------|-----------------------|-----------------|
| A1                                   | Height over steering wheel .....   | 1280 mm/1270 mm .....        | 1300 mm/1270 mm ..... | 1300 mm/1310 mm |
| A2                                   | Height over ROPS .....   | Ask your local ISEKI dealer. |                       |                 |
| B                                    | Minimum width .....  | 1000/1190 mm .....           | 1000 mm/1190 mm ..... | 1160 mm/1215 mm |
| C                                    | Overall length .....   | 2215/2200 mm .....           | 2215 mm/2200 mm ..... | 2680 mm/2680 mm |
| D                                    | Wheelbase .....  | 1425 mm .....                | 1425 mm .....         | 1520 mm         |
| E                                    | Minimum ground clearance .....   | 255 mm/245 mm .....          | 280 mm/245 mm .....   | 280 mm/290 mm   |
|                                      | Turning radius .....   | without brakes .....         | 2600 mm .....         | 2600 mm .....   |
|                                      | (4WD engaged)  | with a brake .....           | 1900 mm .....         | — .....         |
|                                      | Turning radius .....   | without brakes .....         | 2400 mm .....         | 2400 mm .....   |
|                                      | (4WD disengaged)   | with a brake .....           | 2100 mm .....         | — .....         |
| Weight (without ROPS and seat) ..... | 555 kg ... 570 kg ... 585 kg .. 595 kg .. 570 kg ... 575 kg ... 585 kg .. 600 kg .. 610 kg ..... |                              |                       |                 |

## ASSEMBLY & PRE-DELIVERY INSPECTION

**IMPORTANT:** Do not commence assembly of the tractor until reading these instructions completely and carefully.

**NOTE:** For certain lubrication, adjustments, etc., refer to appropriate section of this manual. All nuts, bolts, etc., on these tractors are in METRIC dimensions.

The tractor is shipped in an individual container. The tractor will be partially disassembled to make the container as compact as possible. Wheels, steering, top linkage, and some attaching hardware will be removed.

Larger items will be fastened in the container and the remainder of items will be shipped in sundry boxes also in the container.

To assemble and pre-deliver the tractor, proceed as follows:



**Caution:** Be observant of components such as wheels that may be attached to, or held in position by the container panels.

1. Remove the top and four sides from the container. The easiest way to do this is to cut the corner posts and uprights down near the base of the cart with a circular saw. Then cut out rear 2×4 and cut tie straps. The top and sides of the crate can then be removed from the tractor.
2. Remove wheels and sundry boxes from the container.
3. Inspect the tractor for damage and any evidence of coolant, fuel or lubricant leaks.
4. Inspect and remove all hardware securing the tractor to the lower crate panel.
5. Install the handle on the right hand fender if removed.

6. Front Wheels -
  - a. Carefully raise and block the front of the tractor.
  - b. Install wheel/tyre assemblies and secure them using bolts and lock washers. Tighten them to 102 Nm (75 ft-lbs).
  - c. Lower the front of the tractor.
7. Rear Wheels -
  - a. Carefully raise and block the rear of the tractor.
  - b. Install wheel/tyre assemblies and secure them using bolts and lock washers. Tighten them to 102 Nm (75 ft-lbs.).
  - c. Lower the rear of the tractor.

**NOTE:** Turf wheels will be installed with the valve to the inside. Wider position will prevent interference with check chains.

8. Three-Point-Hitch - is partially assembled with the lift rods attached the lower links and the sway chain attached to the lower links.
  - a. Attach lower links to the tractor attaching points and secure them with lynch pins. The lower link with the adjustable lift rod goes on the right side. The lower links will flare outward at rear when correctly installed.
  - b. Connect clevis-end of the check chains to the axle brackets and secure them with a clevis pin and cotter pin.
9. Clutch Housing Plug – 1/8” pipe plug (1) in Fig. 116 into the hole in the bottom of the clutch housing (TM215/217).

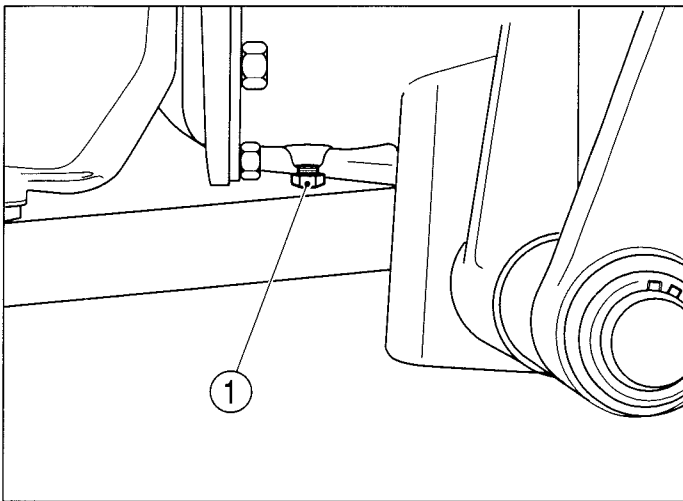

FIG. 117

**PRE-DELIVERY**

- Check that engine oil level is correct.
- Check that coolant level is correct.
- Check fan belt tension, 12 mm (1/2") deflection, when subjected to a force of thumb pressure.
- Check that transmission oil level is correct.
- Install a sufficient amount of No.2 diesel fuel to complete pre-delivery service.
- Ensure clean and tight cable connections at the battery. The battery must be securely mounted.
- Check the air cleaner, element, hoses, and clamps for correct installation.
- Check the brake and clutch pedal linkage for correct free-travel.
- Check steering, brake and clutch linkage cotter pins and lock nuts for secure installation.
- Check the filter element and, all connections and clamps for the hydraulic pump and filter.
- Check oil level in the front axle.
- Place the fuel filter shut-off valve in the "ON" position.
- Take up position in the operator's seat and engage the parking brakes.
- Place all shift levers in neutral and then depress the clutch pedal.
- Place the rear PTO lever (or switch) in neutral (or in off).

**NOTE:** The engine will not start unless the gear shift levers and rear/mid PTO selectors are in neutral.

- Set the throttle lever at half to full throttle and turn the starter key to "GLOW" position until the glow indicator is heated red.
- Turn the starter key to "ON" position. Oil pressure and alternator warning lights will illuminate.
- Turn the starter key to "START" position to crank the engine. Release the key the moment the engine starts. Check that warning lights go out.
- Allow the engine to warm up to operating temperature at about 1500 rpm.
- Operate the tractor to confirm it operates smoothly at all speeds including four-wheel drive.
- Operate the PTO to see that it functions properly.
- Check that all lights and instruments operate properly.
- Check the brakes for balanced operation.
- Check warm engine low idle speed: 850 - 900 rpm.
- Check warm engine high idle speed: 2700 - 2800 rpm (TM215/217); 2900 - 3000 (TM223).
- Set the throttle lever at idle, shut off the engine, and check the tractor for coolant, lubricating oil or fuel leaks.
- Check that safety start system functions correctly.
- Lubricate all fittings.
- Check tyre inflation pressures.
- Check front wheel toe-in.
- Test antifreeze to see that it is adequate for local climate conditions.

**NOTE:** Factory fill is set to -34°C (-30°F).

- Check to see that all safety labels and safety switches are in place.
- Clean and polish sheet metal as necessary.
- Fill the fuel tank to prevent moisture condensation.
- Review this operation manual with the customer when delivering or demonstrating the tractor.

**FACTORY RECOMMENDED  
NEW TRACTOR PRE-DELIVERY INSPECTION CHECK LIST  
ISEKI**

USER'S NAME \_\_\_\_\_ AREA \_\_\_\_\_ DATE \_\_\_\_\_  
 DEALER \_\_\_\_\_ ADDRESS \_\_\_\_\_  
 TRACTOR MODEL \_\_\_\_\_ SERIAL NO. \_\_\_\_\_  
 ENGINE SERIAL NO. \_\_\_\_\_ COUNTRY \_\_\_\_\_

THIS PRE-DELIVERY INSPECTION CHECK LIST IS PROVIDED TO IDENTIFY THE ITEMS CHECKED AND NECESSARY ADJUSTED BY THE DEALER PRIOR TO DELIVERY OF THIS MACHINE.

Inspected the following and adjusted if necessary.

**ENGINE**

- |  |   |
|--|---|
| <input type="checkbox"/> Radiator filled with solution   | <input type="checkbox"/> Engine RPM (full throttle) |
| <input type="checkbox"/> Cooling system connections      | <input type="checkbox"/> Governor performance       |
| <input type="checkbox"/> Fan and alternator belt tension | <input type="checkbox"/> Electrical connections     |
| <input type="checkbox"/> Engine oil                      | <input type="checkbox"/> Service air cleaner        |
| <input type="checkbox"/> All oil drain plugs             | <input type="checkbox"/> Air cleaner connections    |
| <input type="checkbox"/> Oil pressure                    | <input type="checkbox"/> Fuel line connections      |
| <input type="checkbox"/> Engine RPM (idle)               | <input type="checkbox"/> Injection pump oil         |

**CHASSIS**

- |   |  |
|---|--|
| <input type="checkbox"/> Tyre inflation                         | <input type="checkbox"/> Hydraulic system performance                    |
| <input type="checkbox"/> Front wheel hub bolts                  | <input type="checkbox"/> Drive test                                      |
| <input type="checkbox"/> Rear wheel hub bolts                   | <input type="checkbox"/> Lubricate all grease fittings                   |
| <input type="checkbox"/> Torque all chassis bolts               | <input type="checkbox"/> Power-assisted steering operation (if equipped) |
| <input type="checkbox"/> Transmission oil                       | <input type="checkbox"/> Front axle oil (4-WD)                           |
| <input type="checkbox"/> Front reduction case                   | <input type="checkbox"/> Front axle operation (4-WD)                     |
| <input type="checkbox"/> Brake pedal free-play                  | <input type="checkbox"/> Operation manual with tractor                   |
| <input type="checkbox"/> Clutch pedal free-play (TM215 & TM217) |  |

**Explained the following to the owner.**

- |  |  |
|--|--|
| <input type="checkbox"/> Operation manual                                    | <input type="checkbox"/> Fuel system servicing and cleanliness |
| <input type="checkbox"/> Safety and safety start system                      | <input type="checkbox"/> Draining of engine and radiator       |
| <input type="checkbox"/> Instruments and controls                            | <input type="checkbox"/> Air cleaner service                   |
| <input type="checkbox"/> Breaking in the new tractor                         | <input type="checkbox"/> Tyre care                             |
| <input type="checkbox"/> Power take-off operation                            | <input type="checkbox"/> Wheel tread adjustment                |
| <input type="checkbox"/> Lubrication and maintenance schedule                | <input type="checkbox"/> Storage                               |
| <input type="checkbox"/> Explain use of Rollover Protective Structure (ROPS) |  |

DEALER COPY (REMOVE FROM MANUAL)

**FACTORY RECOMMENDED  
NEW TRACTOR PRE-DELIVERY INSPECTION CHECK LIST  
ISEKI**

USER'S NAME \_\_\_\_\_ AREA \_\_\_\_\_ DATE \_\_\_\_\_  
 DEALER \_\_\_\_\_ ADDRESS \_\_\_\_\_  
 TRACTOR MODEL \_\_\_\_\_ SERIAL NO. \_\_\_\_\_  
 ENGINE SERIAL NO. \_\_\_\_\_ COUNTRY \_\_\_\_\_

THIS PRE-DELIVERY INSPECTION CHECK LIST IS PROVIDED TO IDENTIFY THE ITEMS CHECKED AND NECESSARY ADJUSTED BY THE DEALER PRIOR TO DELIVERY OF THIS MACHINE.

Inspected the following and adjusted if necessary.

**ENGINE**

- |  |   |
|--|---|
| <input type="checkbox"/> Radiator filled with solution   | <input type="checkbox"/> Engine RPM (full throttle) |
| <input type="checkbox"/> Cooling system connections      | <input type="checkbox"/> Governor performance       |
| <input type="checkbox"/> Fan and alternator belt tension | <input type="checkbox"/> Electrical connections     |
| <input type="checkbox"/> Engine oil                      | <input type="checkbox"/> Service air cleaner        |
| <input type="checkbox"/> All oil drain plugs             | <input type="checkbox"/> Air cleaner connections    |
| <input type="checkbox"/> Oil pressure                    | <input type="checkbox"/> Fuel line connections      |
| <input type="checkbox"/> Engine RPM (idle)               | <input type="checkbox"/> Injection pump oil         |

**CHASSIS**

- |   |  |
|---|--|
| <input type="checkbox"/> Tyre inflation                         | <input type="checkbox"/> Hydraulic system performance                    |
| <input type="checkbox"/> Front wheel hub bolts                  | <input type="checkbox"/> Drive test                                      |
| <input type="checkbox"/> Rear wheel hub bolts                   | <input type="checkbox"/> Lubricate all grease fittings                   |
| <input type="checkbox"/> Torque all chassis bolts               | <input type="checkbox"/> Power-assisted steering operation (if equipped) |
| <input type="checkbox"/> Transmission oil                       | <input type="checkbox"/> Front axle oil (4-WD)                           |
| <input type="checkbox"/> Front reduction case                   | <input type="checkbox"/> Front axle operation (4-WD)                     |
| <input type="checkbox"/> Brake pedal free-play                  | <input type="checkbox"/> Operation manual with tractor                   |
| <input type="checkbox"/> Clutch pedal free-play (TM215 & TM217) |  |

**Explained the following to the owner.**

- |  |  |
|--|--|
| <input type="checkbox"/> Operation manual                                    | <input type="checkbox"/> Fuel system servicing and cleanliness |
| <input type="checkbox"/> Safety and safety start system                      | <input type="checkbox"/> Draining of engine and radiator       |
| <input type="checkbox"/> Instruments and controls                            | <input type="checkbox"/> Air cleaner service                   |
| <input type="checkbox"/> Breaking in the new tractor                         | <input type="checkbox"/> Tyre care                             |
| <input type="checkbox"/> Power take-off operation                            | <input type="checkbox"/> Wheel tread adjustment                |
| <input type="checkbox"/> Lubrication and maintenance schedule                | <input type="checkbox"/> Storage                               |
| <input type="checkbox"/> Explain use of Rollover Protective Structure (ROPS) |  |

CUSTOMER COPY (LEAVE IN BOOK)